

SL26RT/SL30RT

DIESEL SPEED LEVEL



ADVANCED
ACCESS PLATFORMS

- The original Speed Level sigma lift
- Climbs gradients of up to 50%
- Auto-levelling without the need for outriggers
- Suitable for most terrains
- Powerful 4x4 drive
- Ideal for rough terrain or work at height on sloped ground

 **snorkel**[™]
www.snorkellifts.com

DIESEL SPEED LEVEL

SL26RT/SL30RT

DIMENSIONS	SL26RT	SL30RT
Max. working height	10.0m	11.0m
Max. platform height (A)	8.0m	9.0m
Platform size (stowed)	1.72m x 3.66m	1.72m x 4.23m
Platform size (extended) (B)	1.72m x 4.6m	n/a
Extension deck length	0.91m	n/a
Overall width (C)	2.13m	2.13m
Overall length (D)	3.79m	4.3m
Stowed height (E)	2.6m	2.6m
Min. height (guardrails folded)	1.7m	1.7m
Chassis ground clearance	305mm	305mm
Axle ground clearance	195mm	195mm

PERFORMANCE	SL26RT	SL30RT
Platform capacity (SWL)	680kg	590kg
Max. drive height	8.0m	9.0m
Max. wind speed	12.5m/s	12.5m/s
Max. drive speed (stowed)	6.4km/h	6.4km/h
Max. drive speed (elevated)	0.8km/h	0.8km/h
Raise/lower time	21/32 sec	24/36 sec
Gradeability	50%	50%
Max. levelling, front to rear	9°	9°
Max. levelling, side to side	13°	13°
Inside turning radius	3.9m	3.9m
Outside turning radius	5.64m	5.64m
Tyres	26 x 12.00 - 12 foam filled	
Controls	proportional joystick	
Drive system	4-wheel drive with hydraulic motors and flow dividers	

POWER	SL26RT	SL30RT
Power source	Kubota D-902 water-cooled diesel Tier 4 Final	

WEIGHT	SL26RT	SL30RT
Weight	3,500kg	3,400kg

LEVELLING CAPABILITIES

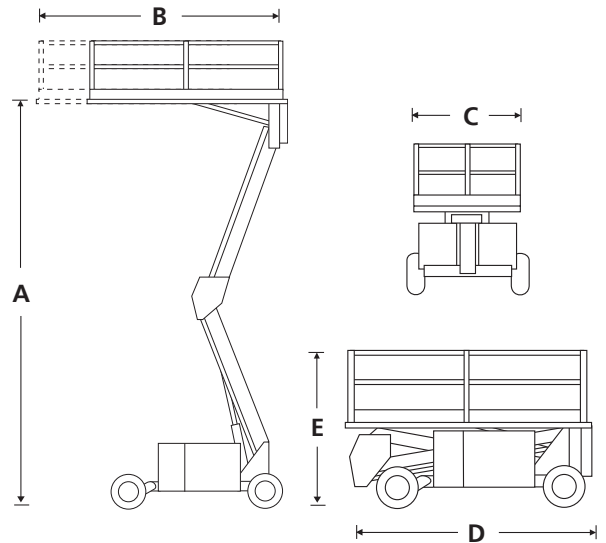
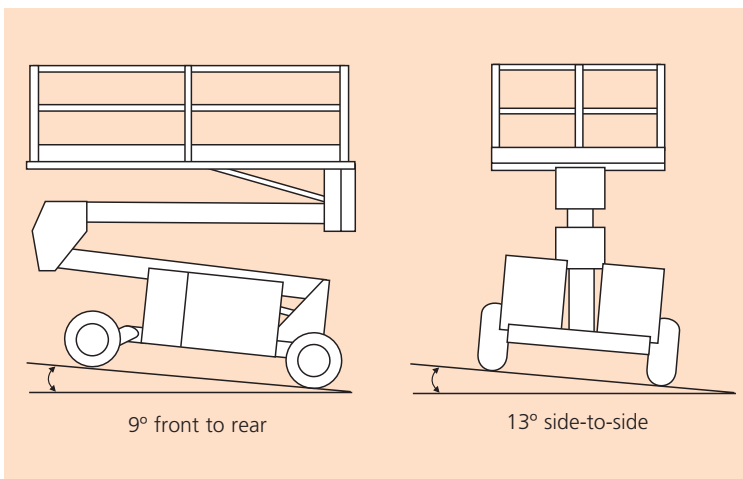

STANDARD FEATURES

- Automatic powered platform levelling
- Powerful 4-wheel drive
- Oscillating front axle
- High grip, open tread deck (SL30RT)
- Roll-out deck extension (SL26RT)
- Descent alarm
- High grip all-terrain tyres
- Dual multi-disc brakes
- Proportional controls
- Power line to platform
- Fold-down guardrails
- All motion alarm
- Flashing amber light
- Hour meter & on-board diagnostics display
- Horn
- 2 year parts & labour, 5 year structural warranty
- CE approved

OPTIONS

- Special paint colours
- Diesel exhaust scrubber
- Environmental hydraulic oil
- Hydraulic generator 110V/240V 3.5kW
- Tunnel package (RT)
- Non-marking tyres
- Aluminium platform floor (SL26RT only)
- Extreme environment package
- Snorkel OnSite™ telematics

snorkel

Vigo Centre, Birtley Road,
Washington, Tyne & Wear,
NE38 9DA, U.K.

ADVANCED
ACCESS PLATFORMS

t: +44 (0) 845 1550 057

e: sales.emea@snorkellifts.com

www.snorkellifts.com