

OPERATOR'S MANUAL

with Maintenance Information

For AMWP8-1200 / AMWP9.5-1200

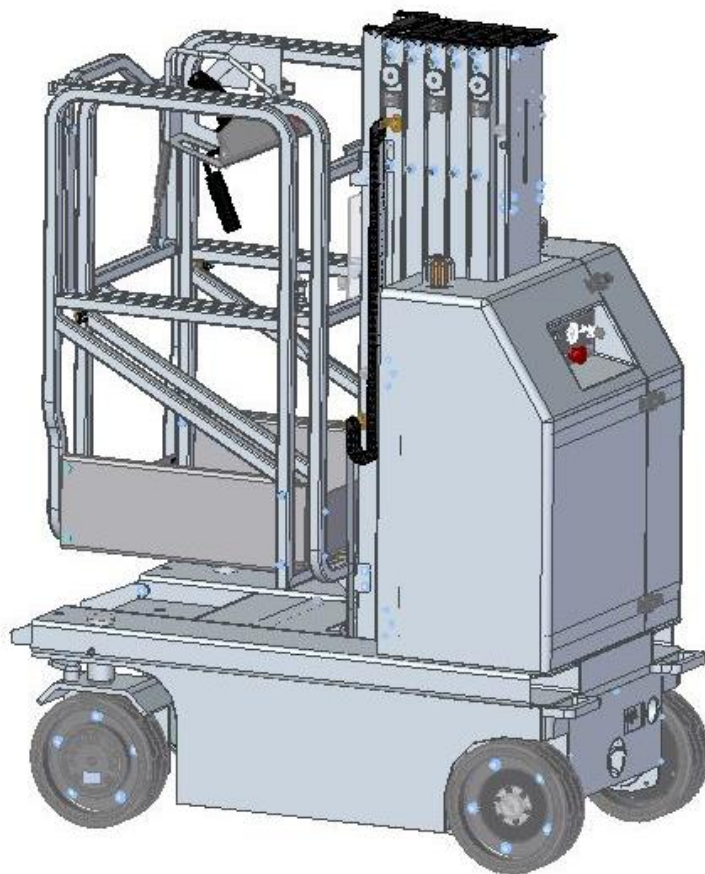

WARNING

THE MANUFACTURER SHALL NOT BE HELD LIABLE IN CASE OF FAULTS OR ACCIDENTS DUE TO NEGLIGENCE, INCAPACITY, INSTALLATION BY UNQUALIFIED TECHNICIANS AND IMPROPER USE OF THE MACHINE

DO NOT OPERATE THIS MACHINE UNTIL YOU READ AND UNDERSTAND ALL THE DANGERS, WARNINGS AND CAUTIONS IN THIS MANUAL

Version of the Record

Version of the Record

Version Number	Create Date
SM0509111_Rev1.0	2019-11
SM0509111_Rev1.1	2021-02
SM0509111_Rev1.2	2021-07

Important

Read, understand and obey these safety rules and operating instructions before operating this machine.

Only trained and authorized personnel shall be permitted to operate this machine. This manual should be considered a permanent part of your machine and should remain with the machine at all times. If you have any questions, please call DINGLI Machinery.

Owners, Users and operators:

Dingli appreciates your choice of our machine for your application. User's safety is our priority, so we hope you can:

- 1 Comply with employer, job site and governmental rules.
- 2 Read, understand and follow the instructions in this and other manuals supplied with this machine.
- 3 Use good safe work practices in a commonsense way.
- 4 Only have trained / certified operators, directed by informed and knowledgeable supervision, running the machine.

If there is anything in this manual that is not clear or which you believe should be added, please contact us.

Contents

	Page
Safety Rules	1
Legend	7
Decals	8
Specifications	11
Control panel	13
Pre-Operating Instructions	16
Workplace Inspection	18
Function Tests	19
Operating Instructions	24
Transport and Lifting Instructions	34
Maintenance	36
Schematic	56
Inspection and Repair Log	58

Contact us:

Zhejiang Dingli Machinery Co., Ltd.

1255 Baiyun South Road. Leidian Town.
Deqing Zhejiang

China

Tel: +86-572-8681688

Fax: +86-572-8681690

Web: www.cndingli.com

E-mail: market@cndingli.com

Safety Rules



Danger

Failure to obey the instructions and safety rules in this manual will result in death or serious injury.

Do Not Operate Unless:

- You learn and practice the principles of safe machine operation contained in this operator's manual.
 - 1 **Avoid hazardous situations.**
Know and understand the safety rules before going on to the next section.
 - 2 Always perform a pre-operation inspection.
 - 3 Always perform function tests prior to use.
 - 4 Inspect the workplace.
 - 5 Only use the machine as it was intended.
- You read, understand and obey the manufacturer's instructions and safety rules— safety and operator's manuals and machine decals.
- You read, understand and obey employer's safety rules and worksite regulations.
- You read, understand and obey all applicable governmental regulations.
- You are properly trained to safely operate the machine.

Decal Legend

DINGLI product decals use symbols, color coding and signal words to identify the following:



Safety alert symbol — used to alert personnel to potential personal injury hazards. Obey all safety messages that follow this symbol to avoid possible injury or death.



DANGER Red — used to indicate the presence of an imminently hazardous situation which, if not avoided, will result in death or serious injury.



WARNING Orange — used to indicate the presence of a potentially hazardous situation which, if not avoided, could result in death or serious personal injury.



CAUTION Yellow with safety alert symbol — used to indicate the presence of a potentially hazardous situation which, if not avoided, may cause minor or moderate personal injury.



NOTICE Blue without safety alert symbol — used to indicate the presence of a potentially hazardous situation which, if not avoided, may result in property damage.

Safety Rules

Intended Use

This machine is intended to be used only to lift personnel, along with their tools and materials to an aerial work site.

 This machine is intended to be used **INDOORS ONLY**, and must not be used outdoors as wind forces may make it unstable.

Safety Sign Maintenance

Replace any missing or damaged safety signs. Keep operator safety in mind at all times. Use mild soap and water to clean safety signs. Do not use solvent-based cleaners because they may damage the material of safety sign.

Electrocution Hazard



This machine is not electrically insulated and will not provide protection from contact with or proximity to electrical current.

Maintain safe

distances from electrical power lines and apparatus in accordance with applicable governmental regulations and the following chart.

Voltage Phase to Phase	Minimum Safe Approach Distance Meters
0 to 300V	Avoid Contact
300V to 50kV	3.05
50kV to 200kV	4.60
200kV to 350kV	6.10
350kV to 500kV	7.62
500kV to 750kV	10.67
750kV to 1000kV	13.72

Keep away from the machine if it contacts energized power lines. Personnel on the ground or in the platform must not touch or operate the machine until energized power lines are shut off.

Do not use the machine as a ground for welding.

Tip-over Hazard

Occupants, equipment and materials must not exceed the maximum platform capacity or the maximum capacity of the platform extension.

 This machine is intended to be used **INDOORS ONLY**, and must not be used outdoors as wind forces may make it unstable.

Maximum capacity

Model	load	occupants
AMWP8-1200	159kg	1
AMWP9.5-1200	136kg	1

 **Do not drive or elevate unless the extension deck is retract.**

Work Area Safety

Do not raise the platform unless the machine is on a firm, level surface.

Do not drive over 1.1km/h with the platform raised.



Do not depend on the tilt alarm as a level indicator. The tilt alarm sounds on the chassis and in the platform only when the machine is on a slope.

Safety Rules

If the tilt alarm sounds:

Lower the platform. Move the machine to a firm, level surface. If the tilt alarm sounds when the platform is raised, use extreme caution to lower the platform.

Do not use the platform controls to free a platform that is caught, snagged or otherwise prevented from normal motion by an adjacent structure. All personnel must be removed from the platform before attempting to free the platform using the ground controls.

Use extreme care and slow speeds while driving the machine in the stowed position across uneven terrain, debris, unstable or slippery surfaces and near holes and drop-offs.

Do not drive the machine on or near uneven terrain, unstable surfaces or other hazardous conditions with the platform raised.



Do not push off or pull toward any object outside of the platform.

Maximum allowable manual force 200N

Do not use the machine as a crane.

Do not place or attach fixed or overhanging loads to any part of this machine.

Do not push the machine or other objects with the platform.

Do not contact adjacent structures with the platform.

Do not alter or disable the limit switches.

Do not tie the platform to adjacent structures.

Do not place loads outside the platform perimeter.



Do not place ladders or scaffolds in the platform or against any part of this machine.

Do not transport tools and materials unless they are evenly distributed and can be safely handled by person(s) in the platform.

Do not use the machine on a moving or mobile surface or vehicle.

Be sure all tires are in good condition, and lug standard parts are properly tightened.

Do not alter or disable machine components that in any way affect safety and stability.

Do not replace items critical to machine stability with items of different weight or specification.

Do not use batteries that weigh less than the original equipment. Batteries are used as counterweight and are critical to machine stability. Each battery must weigh 46 kg.

Do not modify or alter an aerial work platform without prior written permission from the manufacturer. Mounting attachments for holding tools or other materials onto the platform, toe boards or guard rail system can increase the weight in the platform and the surface area of the platform or the load.

▲ **Crushing Hazard**

Keep hands and limbs out of scissors.

Keep the normal judgment and planned operation while operating the machine by ground control box.

Safety Rules

Maintain safe distance between operators, the machine and fixed objects.

⚠️ Operation on Slopes Hazard

Do not drive the machine on a slope that exceeds the slope and side slope rating of the machine.

Slope rating applies to machines only in the stowed position.

Model	Maximum slope rating stowed position	Maximum side slope rating stowed position
AMWP8-1200	25%	10%
AMWP9.5-1200	25%	10%

Note: Slope rating is subject to ground conditions and adequate traction.

⚠️ Fall Hazard



The guard rail system provides fall protection.

During operation, occupants in the platform must wear a full body harness with a lanyard attached to an authorized lanyard anchorage point. Attach only one (1) lanyard per lanyard anchorage point.



Do not sit, stand or climb on the platform guard rails. Maintain a firm footing on the platform floor at all times.

Do not climb down from the platform when raised.

Keep the platform floor clear of debris.

Close the entry gate before operating.

Do not enter or exit the platform unless the machine is in the stowed position.

⚠️ Collision Hazard



Be aware of limited sight distance and blind spots when driving or operating.

Be aware of the extend platform's position when driving.

Check the work area for overhead obstructions or other possible hazards.



Be aware of crushing hazards when grasping the platform guard rail.

Operators must comply with employer, job site and governmental rules regarding use of personal protective equipment.

Observe and use color-coded direction arrows on the platform controls and platform decal plate for drive and steer functions.

Do not operate a machine in the path of any crane or moving overhead machinery unless the controls of the crane have been locked out and/or precautions have been taken to prevent any potential collision.

No stunt driving or horseplay while operating a machine.

Do not lower the platform unless the area below is clear of personnel and obstructions.

Limit travel speed according to the condition of the ground surface, congestion, slope, location of personnel, and any other factors which may cause collision.

Safety Rules

⚠ Component Damage Hazard

Do not use any battery or charger greater than 24V.

Do not use the machine as a ground for welding.

⚠ Explosion and Fire Hazard

Do not operate the machine or charge the battery in hazardous locations or locations where potentially flammable or explosive gases or particles may be present.

⚠ Damaged Machine Hazard

Do not use a damaged or malfunctioning machine.

Conduct a thorough pre-operation inspection of the machine and test all functions before each work shift. Immediately tag and remove from service a damaged or malfunctioning machine.

Be sure all maintenance has been performed as specified in this manual

Be sure all decals are in place and legible.

Be sure the manuals are complete, legible and in the storage container located in the platform.

⚠ Bodily Injury Hazard

Do not operate the machine with a hydraulic oil or air leak. An air leak or hydraulic leak can penetrate and/or burn skin.

Improper contact with components under any cover will cause serious injury. Only trained maintenance personnel should access compartments. Access by the operator is only advised when performing a pre-operation inspection. All compartments must remain closed and secured during operation.

⚠ Battery Safety

⚠ Burn Hazard



Batteries contain acid. Always wear protective clothing and eye wear when working with batteries.

Avoid spilling or contacting battery acid. Neutralize battery acid spills with baking soda and water.

⚠ Explosion Hazard



Keep sparks, flames and lighted tobacco away from batteries. Batteries emit explosive gas.

Do not contact the battery terminals or the cable clamps with tools that may cause sparks.

⚠ Component Damage Hazard

Do not use any battery charger greater than 24V to charge the batteries.

⚠ Electrocution/ Burn Hazard



Connect the battery charger to a grounded, AC 3-wire electrical outlet only.

Inspect daily for damaged cords, cables and wires.

Replace damaged items before operating.

Avoid electrical shock from contact with battery terminals. Remove all rings, watches and other jewelry.

Safety Rules

▲ Tip-over Hazard

Do not use batteries that weigh less than the original equipment. Batteries are used as counterweight and are critical to machine stability. Each battery must weigh 46 kg.

▲ Lifting Hazard

Use the appropriate number of people and proper lifting techniques when lifting batteries.

Lockout after Each Use

- 1 Select a safe parking location - firm level surface, clear of obstruction and traffic.
- 2 Lower the platform.
- 3 Turn the key switch to the off position and remove the key to secure from unauthorized use.
- 4 Chock the wheels.
- 5 Charge the batteries.

Legend

Legend

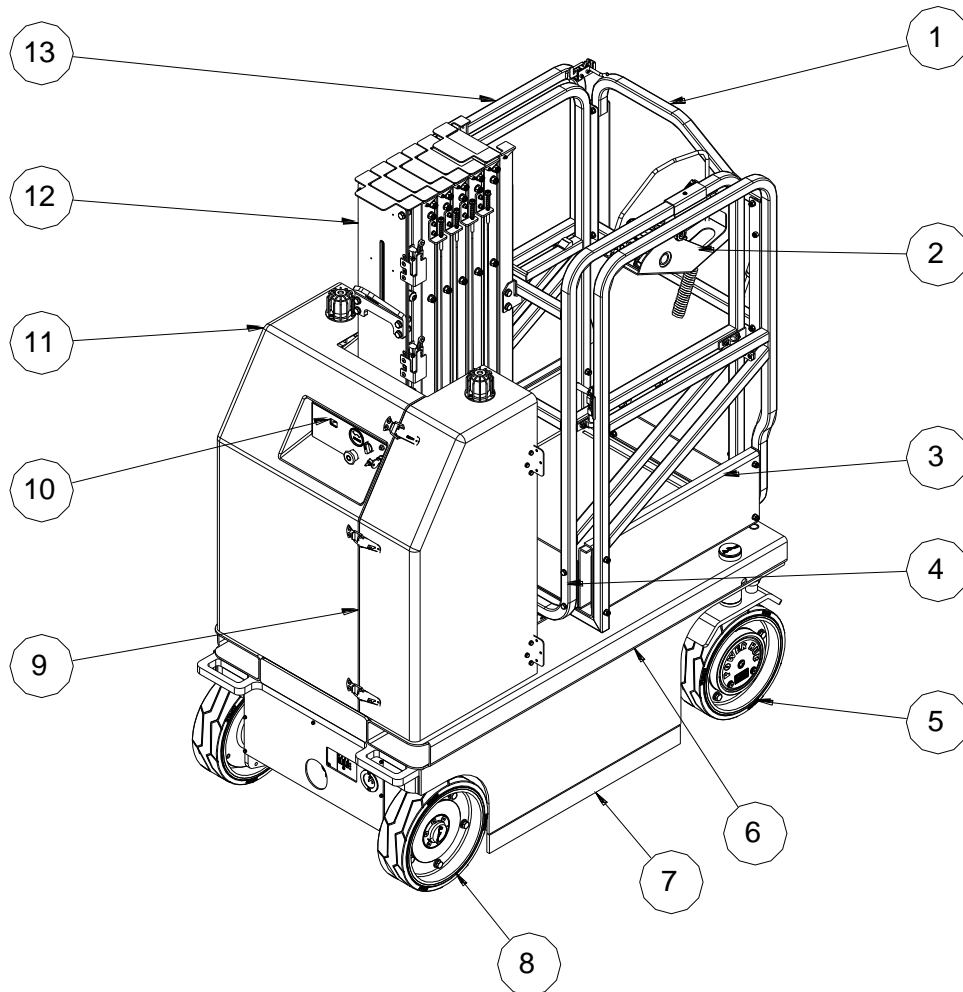

- | | | | |
|---|----------------------------|----|---|
| 1 | Platform entry gate | 8 | Rear Wheel |
| 2 | Platform controls | 9 | Motor/Pump/Reservoir Unit
(located under the cover, and not displayed) |
| 3 | Platform extension | 10 | Ground Control |
| 4 | Main Platform | 11 | Cover |
| 5 | Front Wheel | 12 | Masts Assembly |
| 6 | Chassis | 13 | Platform guard rails |
| 7 | Pothole device | | |

Decals

Decal Inspection

Use the pictures on the next page to verify that all decals are legible and in place.

Below is a numerical list with quantities and descriptions.

No.	Part No.	Description	Qty.	Remark
1	09440227	Decal, Danger-Tip-over hazard, tilt-alarm	1	
2	09440257	Decal, Label-Capacity 159kg	1	AMWP8-1200
	09440214	Decal, Label-Capacity 136kg	1	AMWP9.5-1200
3	09310006	Decal, Notice-Main power switch operation	1	
4	09310294	Decal, Instructions-Maximum wheel load 425kg	4	AMWP8-1200
	09310296	Decal, Instructions-Maximum wheel load 500kg	4	AMWP9.5-1200
5	09540001	Decal, Label-CE	2	
6	09540002	Decal, Label-IPAF	2	
7	09310003	Decal, Instructions-Tie down point	4	
8	09420017	Decal, Danger-Do not stand	1	
9	09430026	Decal, Warning-Crushing hazard	1	
10	09340003	Decal, Instructions-Refer the operator to the instructions for use	2	
11	09340016	Decal, Instructions-Open/close	1	
12	09440233	Decal, Warning-Tip-over hazard	1	
13	09440235	Decal, Warning-Crushing hazard/ Falling hazard	1	
14	09440011	Decal, Label-Lanyard anchorage point	2	
15	09440231	Decal, Warning-Use indoors only	1	
16	09440066	Decal, Caution-Max. manual force 200N	1	
17	09440229	Decal, Danger-Electrocution hazard	1	
18	09310001	Decal, Instructions-Forklift pockets	2	
19	09310004	Decal, Instructions-Emergency lower	1	
20	09410001	Decal, Danger-Explosion/burn hazard	1	

Decals

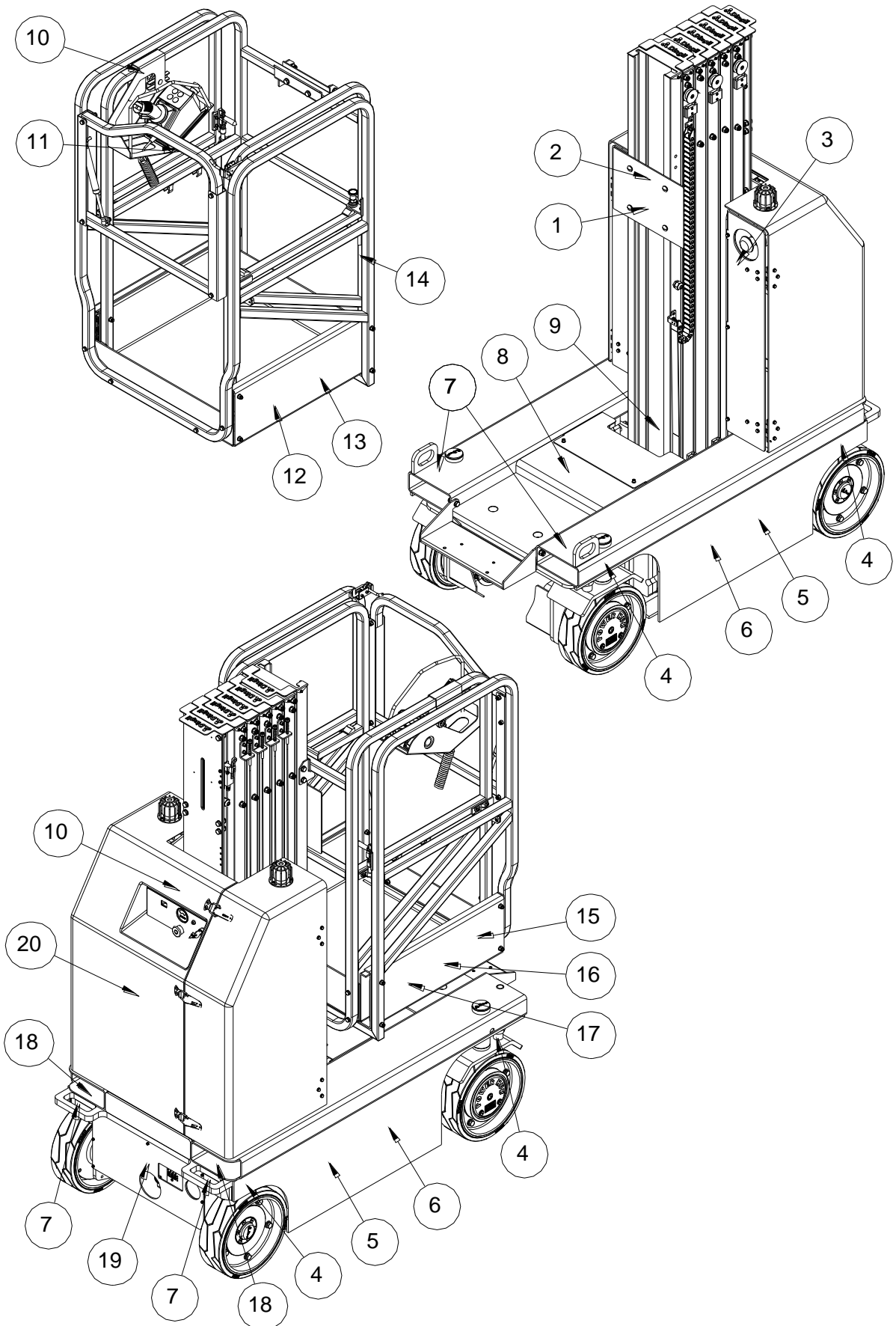

Decals

<p>① 09440227</p> 	<p>② 09440257</p> 	<p>② 09440214</p> 			
<p>③ 09310006</p> 	<p>④ 09310294</p> 	<p>④ 09310296</p> 	<p>⑤ 09540001</p> 	<p>⑦ 09310003</p> 	
<p>⑩ 09340003</p> 	<p>⑥ 09540002</p> 	<p>⑨ 09430026</p> 	<p>⑧ 09420017</p> 		
<p>⑫ 09440233</p>	<p>⑪ 09340016</p> 	<p>⑭ 09440011</p> 	<p>⑬ 09440235</p> 	<p>⑮ 09440066</p> 	<p>⑱ 09310001</p> 
<p>⑬ 09440235</p> 	<p>⑲ 09310004</p> 	<p>⑳ 09410001</p>	<p>⑳ 09410001</p> 		
<p>⑮ 09440231</p> 	<p>⑰ 09440229</p> 				

Specifications**AMWP8-1200**

Height, working maximum	8.0m	Driving wheels	Φ323×100mm
Height, platform maximum	6.0m	Airborne noise emissions	<70dB
Height, stowed maximum	1.99m	Maximum sound level at normal operating workstations (A-weighted)	
Height, guard rails	1.1m	Vibration value does not exceed	2.5m/s ²
Width	0.76m	Maximum slope rating Stowed position	25%
Length, platform retracted	1.39m	Maximum side slope rating Stowed position	10%
Platform dimensions Platform length x width	0.73×0.75m	Note: Slope rating is subject to ground conditions and adequate traction.	
Maximum load capacity	159kg	Maximum working slope	X-1.5°, Y-3°
Maximum wind speed	0m/s	Drive speeds	
Wheelbase	1.07m	Stowed, maximum	4.0km/h
Turning radius (outside)	1.55m	Platform raised, maximum	1.1km/h
Turning radius (inside)	0m	Floor loading information	
Ground clearance	6cm	Tire load, maximum	425kg
Ground clearance Pothole guards deployed	1.4cm	Tire contact pressure	8.1kg/cm ² 793.8kPa
Weight (See Serial Label)		Occupied floor pressure	1150kg/m ² 11.27kPa
Machine weights vary with option configurations		Note: Floor loading information is approximate and does not incorporate different option configurations. It should be used only with adequate safety factors.	
Power source	2×12V 115Ah	Continuous improvement of our products is a DINGLI policy. Product specifications are subject to change without notice or obligation.	
Controls	Proportional		
AC outlet in platform	Standard		
Maximum hydraulic pressure (functions)	180bar		
System voltage	24V		

Specifications

AMWP9.5-1200

Height, working maximum	9.5m	Driving wheels	Φ323×100mm
Height, platform maximum	7.5m	Airborne noise emissions	<70dB
Height, stowed maximum	1.99m	Maximum sound level at normal operating workstations (A-weighted)	
Height, guard rails	1.1m	Vibration value does not exceed	2.5m/s ²
Width	0.80m	Maximum slope rating Stowed position	25%
Length, platform retracted	1.44m	Maximum side slope rating Stowed position	10%
Platform dimensions Platform length x width	0.73×0.75m	Note: Slope rating is subject to ground conditions and adequate traction.	
Maximum load capacity	136kg	Maximum working slope	X-1.5°, Y-3°
Maximum wind speed	0m/s	Drive speeds	
Wheelbase	1.12m	Stowed, maximum	4.0km/h
Turning radius (outside)	1.58m	Platform raised, maximum	1.1km/h
Turning radius (inside)	0m	Floor loading information	
Ground clearance	6cm	Tire load, maximum	500kg
Ground clearance Pothole guards deployed	1.4cm	Tire contact pressure	10.5kg/cm ² 1028.0kPa
Weight	(See Serial Label)	Occupied floor pressure	1489kg/m ² 14.59kPa
Machine weights vary with option configurations		Note: Floor loading information is approximate and does not incorporate different option configurations. It should be used only with adequate safety factors.	
Power source	2×12V 115Ah	Continuous improvement of our products is a DINGLI policy. Product specifications are subject to change without notice or obligation.	
Controls	Proportional		
AC outlet in platform	Standard		
Maximum hydraulic pressure (functions)	180bar		
System voltage	24V		

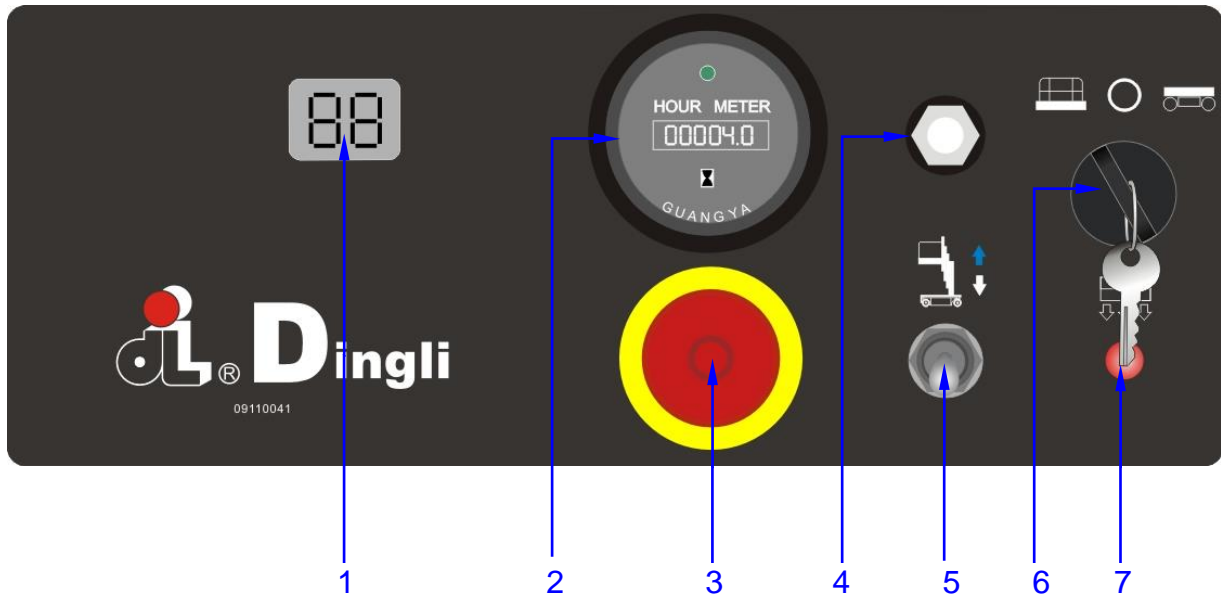
Control Panel**Ground Control Panel****1 LED**

Diagnostic read out and battery charge indicator.

2 Hour meter

The hour meter displays the number of hours the machine has operated

3 Red Emergency Stop button

Push in the red Emergency Stop button to the off position to stop all functions. Turn the red Emergency Stop button clockwise to the on position to operate the machine.

4 Circuit breaker

When the current was overloaded, the circuit breaker will cut off the circuit.

5 Platform up / down switch

Move the switch up and the platform will raise. Move the switch down and the platform will lower.

6 Key switch for platform / off / ground control selection.

Turn the key switch to the platform position and the platform controls will operate. Turn the key switch to the off position and the machine will be off. Turn the key switch to the base position and the ground controls will operate.

7 Overload indicator light

Light on indicates when overloaded.

Control Panel

Platform Control Panel

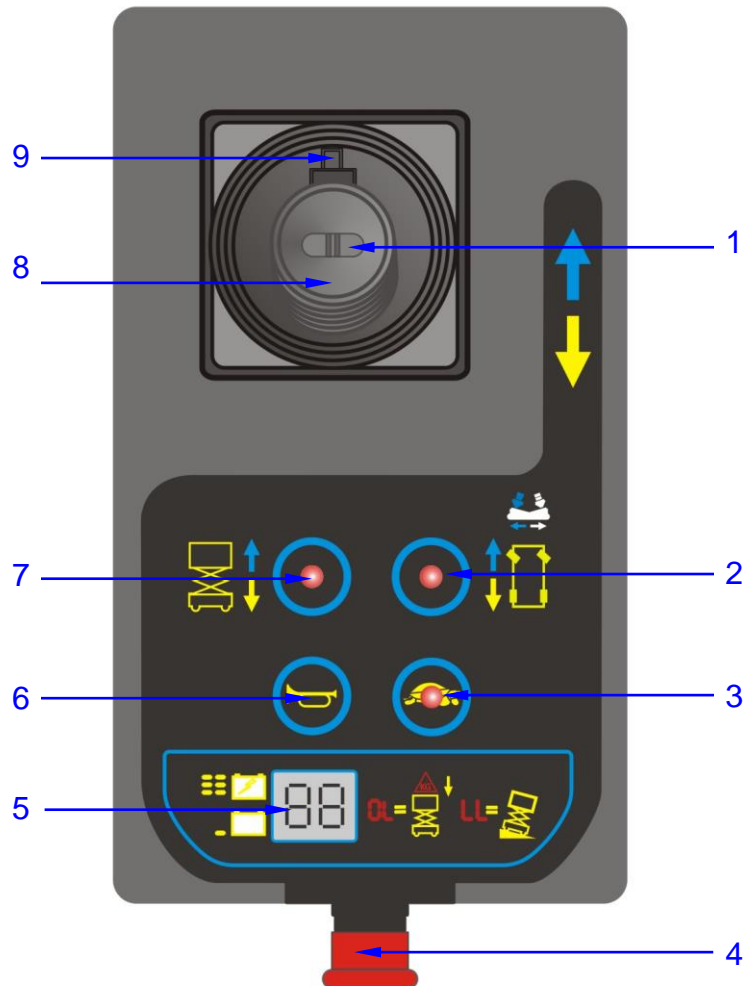

- | | | | |
|---|---|---|---|
| 1 | Thumb rocker switch for steer functions | 6 | Horn button |
| 2 | Drive function select button | 7 | Lift function select button |
| 3 | Drive speed button | 8 | Proportional control handle |
| 4 | Red Emergency Stop button | 9 | Function enable switch for lift and drive functions |
| 5 | LED | | |

Control Panel

Platform Control Panel

- 1 Thumb rocker switch for steer functions
Press the thumb rocker switch in either direction to activate steer function.
- 2 Drive function select button
Press this button to activate the drive function.
- 3 Drive speed button
Press this button to activate the slow or fast drive function.
- 4 Red Emergency Stop button
Push in the red Emergency Stop button to the off position to stop all functions. Turn the red Emergency Stop button clockwise to the on position to operate the machine.
- 5 LED
Diagnostic read out and battery charge indicator.
- 6 Horn Button
Push the horn button and the horn will sound. Release the horn button and the horn will stop.
- 7 Lift function select button
Press this button to activate the lift function.

8 Proportional control handle

Lift function: Press and hold the function enable switch to enable the lift function on the platform control handle. Move the control handle in the direction indicated by the blue arrow and the platform will raise. Move the control handle in the direction indicated by the yellow arrow and the platform will lower. The descent alarm should sound while the platform is lowering.

Drive function: Press and hold the function enable switch to enable the drive function on the platform control handle. Move the control handle in the direction indicated by the blue arrow on the control panel and the machine will move in the direction that the blue arrow points. Move the control handle in the direction indicated by the yellow arrow on the control panel and the machine will move in the direction that the yellow arrow points.

9 Function enable switch

Press and hold the function enable switch to enable the drive/lift function.

Pre-operation Inspection



Do Not Operate Unless:

You learn and practice the principles of safe machine operation contained in this operator's manual.

- 1 Avoid hazardous situations.
- 2 Always perform a pre-operation inspection.**

Know and understand the pre-operation inspection before going on to the next section.

- 3 Inspect the workplace.
- 4 Always perform function tests prior to use.
- 5 Only use the machine as it was intended.

Fundamentals

It is the responsibility of the operator to perform a pre-operation inspection and routine maintenance.

The pre-operation inspection is a visual inspection performed by the operator prior to each work shift. The inspection is designed to discover if anything is apparently wrong with a machine before the operator performs the function tests.

The pre-operation inspection also serves to determine if routine maintenance procedures are required. Only routine maintenance items specified in this manual may be performed by the operator.

Refer to the list on the next page and check each of the items.

If damage or any unauthorized variation from factory delivered condition is discovered, the machine must be tagged and removed from service.

Repairs to the machine may only be made by a qualified service technician, according to the manufacturer's specifications. After repairs are completed, the operator must perform a pre-operation inspection again before going on to the function tests.

Scheduled maintenance inspections shall be performed by qualified service technicians, according to the manufacturer's specifications and the requirements listed in this manual.

Pre-operation Inspection

Pre-operation Inspection

- Be sure that the operator's manual are complete, legible and in the storage container located in the platform.
- Be sure that all decals are legible and in place. See Decals section.
- Check for hydraulic oil leaks and proper oil level. Add oil if needed. See Maintenance section.
- Check for battery fluid leaks and proper fluid level. Add distilled water if needed. See Maintenance section.

Check the following components or areas for damage, improperly installed or missing parts and unauthorized modifications:

- Electrical components, wiring and electrical cables
- Hydraulic hoses, fittings, cylinders and manifolds
- Battery pack and connections
- Drive motors
- Rollers and slide blocks on masts
- Tires and wheels
- Lifting chains and idler wheels
- Mast and mast braces
- Limit switches, alarms and horn
- Nuts, bolts and other fasteners
- Platform entry gate and guard rail
- Alarms and beacons
- Platform extension
- Platform Control Panel
- Pothole guard
- Wire

Check entire machine for:

- Cracks in welds or structural components
- Dents or damage to machine
- Be sure that all structural and other critical components are present and all associated fasteners and pins are in right place and properly tightened.

Workplace Inspection



Do Not Operate Unless:

You learn and practice the principles of safe machine operation contained in this operator's manual.

- 1 Avoid hazardous situations.
- 2 Always perform a pre-operation inspection.

3 Inspect the workplace.

Know and understand the workplace inspection before going on to the next section.

- 4 Always perform function tests prior to use.
- 5 Only use the machine as it was intended.

Fundamentals

The workplace inspection helps the operator determine if the workplace is suitable for safe machine operation. It should be performed by the operator prior to moving the machine to the workplace.

It is the operator's responsibility to read and remember the workplace hazards, then watch for and avoid them while moving, setting up and operating the machine.

Workplace Inspection

Be aware of and avoid the following hazardous situations:

- Drop-offs or holes
- Bumps, floor obstructions or debris
- Sloped surfaces
- Unstable or slippery surfaces
- Overhead obstructions and high voltage conductors
- Hazardous locations
- Inadequate surface support to withstand all load forces imposed by the machine
- The presence of unauthorized personnel
- Other possible unsafe conditions

Function Tests



Do Not Operate Unless:

You learn and practice the principles of safe machine operation contained in this operator's manual.

- 1 Avoid hazardous situations.
- 2 Always perform a pre-operation inspection.
- 3 Inspect the workplace.
- 4 **Always perform function tests prior to use.**

Know and understand the function tests before going on to the next section.

- 5 Only use the machine as it was intended.

Fundamentals

The function tests are designed to discover any malfunctions before the machine is put into service.

The operator must follow the step-by-step instructions to test all machine functions.

A malfunctioning machine must never be used. If malfunctions are discovered, the machine must be tagged and removed from service.

Repairs to the machine may only be made by a qualified service technician, according to the manufacturer's specifications.

After repairs are completed, the operator must perform a pre-operation inspection and function tests again before putting the machine into service.

Function Tests

- 1 Select a test area that is firm, level and free of obstruction.
- 2 Be sure the battery pack is connected.
- 3 Pull out the main power switch to "on" position.

At the Ground Controls

- 4 Turn the ground red Emergency Stop button clockwise to the on position. Pull out the platform red Emergency Stop button to the on position.
- 5 Turn the key switch to ground control.
- 6 Observe the LED readout screen on the platform controls.

- ⊙ Result: The LED should look like the picture at right.



- 7 Observe the LED readout screen on the ECU window.

- ⊙ Result: The LED should look like the picture at right.



Test Emergency Stop

- 8 Push in the ground red Emergency Stop button to the off position.
- ⊙ Result: No functions should operate.
- 9 Pull out the red Emergency Stop button to the on position.

Test Up/Down Functions

A buzzer with different sound frequency is controlled in central system. The descent alarm sounds at 60 beeps per minute. The descent delay alarm sounds at 120 beeps per minute. The alarm that goes off when the pothole guards have not deployed sounds at 180 beeps per minute. The alarm that goes off when the machine is not level sounds at 180

beeps per minute. An optional automotive-style horn is also available.

- 10 Turn the key switch to off or platform position.
- 11 Move up and hold the platform up / down switch.

- ⊙ Result: No function should operate.

- 12 Turn the key switch to ground control position.
- 13 Move up and hold the platform up / down switch.

- ⊙ Result: The platform should raise.

- 14 Move down and hold the platform up / down switch.

- ⊙ Result: The platform should lower. The descent alarm should sound while the platform is lowering. The platform stop at the height is approximately 1.3m from the ground. The descent delay alarm will sound.

Note: Be sure the area below the platform is clear of personnel and obstructions before continuing.

- 15 Move down and hold the platform up / down switch.

- ⊙ Result: The platform should lower to end. The descent delay alarm should sound while the platform is lowering.

Test the Emergency Lowering

- 16 Activate the up function and raise the platform approximately 60 cm.

- 17 Pull the emergency lowering knob.

- ⊙ Result: The platform should lower. The descent alarm will not sound.

- 18 Turn the key switch to platform control.

Function Tests

At the Platform Controls

Test Emergency Stop

- 19 Push in the platform red Emergency Stop button to the off position.
 - ⊙ Result: No functions should operate.
- 20 Pull the red Emergency Stop button out to the on position.
 - ⊙ Result: The LED indicator light should come on.

Test the Horn

- 21 Push the horn button.
 - ⊙ Result: The horn should sound.

Test Function Enable and Up/Down Functions

- 22 Do not hold the function enable switch on the control handle.
- 23 Slowly move the control handle in the direction indicated by the blue arrow, then in the direction indicated by the yellow arrow.
 - ⊙ Result: No functions should operate.
- 24 Press the lift function select button.
- 25 Press and hold the function enable switch on the control handle.
- 26 Slowly move the control handle in the direction indicated by the blue arrow.
 - ⊙ Result: The platform should raise. The pothole guards should deploy.
- 27 Release the control handle.
 - ⊙ Result: The platform should stop raising.
- 28 Press and hold the function enable switch. Slowly move the control handle in the direction indicated by the yellow arrow.
 - ⊙ Result: The platform should lower. The descent alarm should sound while the platform is lowering.

Test the Steering

Note: When performing the steer and drive function tests, stand in the platform facing the steer end of the machine.

- 29 Press the drive function select switch. The indicator light should turn on.
- 30 Press and hold the function enable switch on the control handle.
- 31 Depress the thumb rocker switch on top of the control handle in the direction identified by the blue left arrow on the control panel.
 - ⊙ Result: The steer wheels should turn in the direction that the blue left arrow points on the control panel.
- 32 Depress the thumb rocker switch in the direction identified by the yellow right arrow on the control panel.
 - ⊙ Result: The steer wheels should turn in the direction that the yellow right arrow points on the control panel.

Test Drive and Braking

- 33 Press the drive function select button. The indicator light should turn on.
- 34 Press and hold the function enable switch on the control handle.
- 35 Slowly move the control handle in the direction indicated by the blue arrow on the control panel until the machine begins to move, then return the handle to the center position.
 - ⊙ Result: The machine should move in the direction that the blue arrow points on the control panel, then come to an abrupt stop.
- 36 Press and hold the function enable switch on the control handle.
- 37 Slowly move the control handle in the direction indicated by the yellow arrow on the control panel until the machine begins to move, then return the handle to the

Function Tests

center position.

- ⊙ Result: The machine should move in the direction that the yellow arrow points on the control panel, then come to an abrupt stop.

Note: The brakes must be able to hold the machine on any slope that is able to climb.

Test Limited Drive Speed

38 Press the lift function select button. The indicator light should turn on. Press and hold the function enable switch. Raise the platform approximately 2 m from the ground.

- ⊙ Result: The pothole guards should deploy.

39 Press the drive function select button. The indicator light should turn on.

40 Press and hold the function enable switch on the control handle. Slowly move the control handle to the full drive position.

- ⊙ Result: The maximum achievable drive speed with the platform raised should not exceed 20 cm/s.

⊘ Result: If the drive speed with the platform raised exceeds 20 cm/s, immediately tag and remove the machine from service.

Test the Tilt Sensor Operation

Note: Perform this test from the ground with the platform controller. Do not stand in the platform.

41 Fully lower the platform.

42 Place a 3x10cm or similar piece of wood under both wheels on one side and drive the machine up onto them.

43 Raise the platform at least 2 m.

- ⊙ Result: The platform should stop and the tilt alarm will sound at 180 beeps per minute. The platform controls LED readout should display "LL".

44 Press the drive function select button.

45 Press and hold the function enable switch on the control handle.

46 Move the drive control handle in the direction indicated by the blue up arrow, then move the drive control handle in the direction indicated by the yellow arrow.

- ⊙ Result: The drive function should not work in either direction.

47 Lower the platform and drive the machine off the block.

Test the Pothole Guards

Note: The pothole guards should automatically deploy when the platform is raised. The pothole guards activate another limit switch which allows the machine to continue to function. If the pothole guards do not deploy, an alarm sounds and the machine will not drive and lift.

48 Raise the platform.

- ⊙ Result: When the platform is raised approximately 2m from the ground, the pothole guards should deploy.

49 Press on the pothole guards on one side, and then the other side.

- ⊙ Result: The pothole guards should not move.

50 Lower the platform.

- ⊙ Result: The pothole guards should return to the stowed position.

51 Place a 5x10cm or similar piece of wood under a pothole guard. Raise the platform.

- ⊙ Result: When the platform is raised approximately 2m from the ground, the pothole alarm will sound at 180 beeps per minute, and the platform controls LED screen readout should display "58".

52 Press the drive function select button.

Function Tests

- 53 Press and hold the function enable switch on the control handle.
- 54 Move the control handle in the direction indicated by the blue arrow, and then move the control handle in the direction indicated by the yellow arrow.
- ⊙ Result: The drive function should not work in either direction.
- 55 Press and hold the function enable switch on the control handle.
- 56 Depress the thumb rocker switch on top of the control handle in the direction identified by the blue and yellow arrow on the control panel.
- ⊙ Result: The steer function should not work in either direction.
- 57 Lower the platform and remove the 5x10 wood block.

Operating Instructions



Do Not Operate Unless:

- You learn and practice the principles of safe machine operation contained in this operator's manual.
- 1 Avoid hazardous situations.
- 2 Always perform a pre-operation inspection.
- 3 Inspect the workplace.
- 4 Always perform function tests prior to use.
- 5 Only use the machine as it was intended.**

Fundamentals

This machine is a self-propelled hydraulic lift equipped with a work platform on the Vertical mechanism. Vibrations emitted by these machines are not hazardous to an operator in the work platform. The machine can be used to position personnel with their tools and supplies at position above ground level and can be used to reach work areas located above and over machinery or equipment.

A full and detailed implementation of EN ISO 13849-1/2 is correctly applied on our MEWP design. SISTEMA, a software tool for PL Calculation Tool, is also used to perform some relatively straightforward calculations on subsystem to determine the overall PL of the system. Reliability data, diagnostic coverage [DC], the system architecture [Category], common cause failure and, where relevant, requirements for software are used to assess the PL to comply with PLr of SRP/CS in Clause 5.11 of EN 280.

The Operating Instructions section provides instructions for each aspect of machine operation.

It is the operator's responsibility to follow all the safety rules and instructions in the operator's, safety and responsibilities manuals.

Using the machine for anything other than lifting personnel, along with their tools and materials, to an aerial work site is unsafe and dangerous.

Only trained and authorized personnel should be permitted to operate a machine. If more than one operator is expected to use a machine at different times in the same work shift, they must all be qualified operators and are all expected to follow all safety rules and instructions in the operator's, safety and responsibilities manuals. That means every new operator should perform a pre-operation inspection, function tests, and a workplace inspection before using the machine.

Operating Instructions

Emergency Stop

Push in the red Emergency Stop button to the off position at the ground controls or the platform controls to stop all machine functions.

Repair any function that operates when either red Emergency Stop button is pushed in.

Emergency Lowering

- 1 Pull the emergency lowering knob to lower the platform.

Operation from Ground

- 1 Turn the key switch to ground control.
- 2 Pull out both ground and platform red Emergency Stop buttons to the on position.
- 3 Be sure the battery pack is connected before operating the machine.

To Position Platform

- 1 Move the up/down switch according to the markings on the control panel.

Drive and steer functions are not available from the ground controls.

Operation from Platform

- 1 Turn the key switch to platform control.
- 2 Pull out the ground and platform red Emergency Stop buttons to the on position.
- 3 Be sure the battery pack is connected before operating the machine.

To Position Platform

- 1 Press the lift function select button.
- 2 Press and hold the function enable switch on the control handle.

- 3 Move the control handle according to the markings on the control panel.

To Steer

- 1 Press the drive function select button.
- 2 Press and hold the function enable switch on the control handle.
- 3 Turn the steer wheels with the thumb rocker switch located on the top of the control handle.

To Drive

- 1 Press the drive function select button.
- 2 Press and hold the function enable switch on the control handle.
- 3 Increase speed: Slowly move the control handle off center.

Decrease speed: Slowly move the control handle toward center.

Stop: Return the control handle to center or release the function enable switch.

Use the color-coded direction arrows on the platform controls and on the platform to identify the direction the machine will travel.

Machine travel speed is restricted when the platform is raised.

Battery condition will affect machine performance. Machine drive speed and function speed will drop when the battery level indicator is flashing.

To select drive speed

The drive controls can operate in two different drive speed modes. When the drive speed button light is on, slow drive speed mode is active. When the button light is off, fast drive speed mode is active.

Press the drive speed button to select the desired drive speed.

Note: When the platform is elevated, the drive

Operating Instructions

speed button light is always on, indicating elevated drive speed.

▲ Driving on a slope

Determine the slope and side slope ratings for the machine and determine the slope grade.

Maximum slope rating, stowed position 25%,

Maximum side slope rating, stowed position 10%

Note: Slope rating is subject to ground conditions and adequate traction.

Press the drive speed button to the fast drive speed mode.

To determine the slope grade

Measure the slope with a digital inclinometer OR use the following procedure.

You will need:

Carpenter's level

Straight piece of wood, at least 1m long

Tape measure

Lay the piece of wood on the slope.

At the downhill end, lay the level on the top edge of the piece of wood and lift the end until the piece of wood is level.

While holding the piece of wood level, measure the distance from the bottom of the piece of wood to the ground.

Divide the tape measure distance (rise) by the length of the piece of wood (run) and multiply by 100.

Example:

Run = 3.6 m

Rise = 0.3 m



$$0.3 \text{ m} \div 3.6 \text{ m} = 0.083 \times 100 = 8.3\%$$

If the slope exceeds the maximum slope or side slope rating, the machine must be winched or transported up or down the slope. See Transport and Lifting section.

Operation from Ground with Controller

Maintain safe distances between operator, machine and fixed objects.

Be aware of the direction the machine will travel when using the controller.

Battery Level Indicator



Use the LED readout screen to determine the battery level.

To Extend and Retract Platform

- 1 Pull and turn the platform lock pin handle on the extension deck.
- 2 Push the platform extension guardrail to extend the platform.
- 3 Turn the handle and push the platform lock pin to the socket on the extension deck.
- 4 Reverse the above steps to retract platform.

NOTE: Do not stand on the platform extension while trying to extend and retract it.

Operating Instructions

Error indicator readout



The LED readout screen displays fault codes that provide information about the machine operating status and about malfunctions. The fault codes listed in the following charts describe malfunctions and can aid in troubleshooting the machine by pinpointing the area or component affected.

List of Fault Codes

Display	Description	Lift Reaction
01	System initialization Fault	Disables All Motion
02	System communication Fault	Disables All Motion
03	Invalid option setting Fault	Disables All Motion
09	GPS communication Fault	Disables All Motion
12	Chassis Up/Down Switch ON at Power-up Fault	Disable Chassis Control
18	Pothole Guard Fault	Disable Lifting and Driving
31	Pressure Sensor Fault	Disables All Motion
32	Angle Sensor Fault	Disables All Motion
35	Pressure Sensor 2 Fault	Disables All Motion
36	Low Battery Alert	Warning Only
42	Platform Left Turn Switch ON at power-up Message	Warning Only
43	Platform Right Turn Switch ON at power-up Message	Warning Only
46	Platform Joystick Enable Switch ON at power-up Fault	Disable Platform Control
47	Platform Joystick not in neutral at power-up Message	Warning Only
52	Drive Forward Coil Fault	Disable Lifting and Driving
53	Drive Reverse Coil Fault	Disable Lifting and Driving
54	Lift Up Coil Fault	Disable Lifting and Driving
55	Lift Down Coil Fault	Disable Lifting and Driving
56	Right Turn Coil Fault	Disable Lifting and Driving
57	Left Turn Coil Fault	Disable Lifting and Driving
58	General Brake Coil Fault	Disable Lifting and Driving
59	Parallel Coil Fault	Disable Lifting and Driving
60	Motor Controller Fault	Controller Dependent
61	Motor Controller Current Sensor Fault	Controller Dependent
62	Motor Controller Hardware Failsafe Fault	Controller Dependent
63	Motor Controller Motor Output Fault	Controller Dependent

Operating Instructions

Display	Description	Lift Reaction
64	Motor Controller SRO Fault	Controller Dependent
65	Motor Controller Throttle Fault	Controller Dependent
66	Motor Controller Emergency Reverse Fault	Controller Dependent
67	Motor Controller HPD Fault	Controller Dependent
68	Low Voltage Fault	Disable All Motion
69	High Neutral Current Fault (ZAPI Only)	Disable All Motion
70	Steering Input Out of Range (ZAPI Only)	Disable All Motion
71	Motor Controller Main Contactor Fault	Disable Lifting and Driving
72	Motor Controller Over Voltage Fault	Controller Dependent
73	Motor Controller Thermal Cutback Fault	Controller Dependent
74	Motor Controller Motor Fault	Controller Dependent
75	Motor Controller Pump Motor Fault	Controller Dependent
76	Motor Controller Left Drive Motor Fault	Controller Dependent
77	Motor Controller Right Drive Motor Fault	Controller Dependent
78	Pump Motor Short Fault	Disable Lifting and Driving
79	Left Drive Motor Short Fault	Disable Lifting and Driving
80	Over 80% Load Warning	Warning Only
81	Right Drive Motor Short Fault	Disable Lifting and Driving
82	Left Brake Coil Fault	Disable Lifting and Driving
83	Right Brake Coil Fault	Disable Lifting and Driving
84	Motor Post Shorted	Disable Lifting and Driving
85	Brake Release Switch On	Warning Only
86	Brake Release Not Showed	Warning Only
87	Brake Release	Warning Only
89	Motor Field Open	Disable Lifting and Driving
90	Over 90% Load Warning	Warning Only
91	Left Motor Field Short	Disable Lifting and Driving
92	Right Motor Field Short	Disable Lifting and Driving
99	Over 99% Load Warning	Warning Only
OL	Overloaded Platform Fault	Disable All Motion
LL	Machine Tilted Beyond Safe Limits Fault	Disable Lifting and Driving

Operating Instructions**Troubleshooting Guide**

Display	Description
01	System Initialization Fault: ECU may be malfunctioning, replace it.
02	System Communication Fault: Check communications cable connections and other wiring. If that does not resolve the problem, try replacing the PCU or ECU.
03	Invalid Option setting Fault: Set appropriate option for this lift.
09	GPS Communication Fault: Check communications cable connections and other wiring. If that does not resolve the problem, try replacing the GPS.
12	Chassis Toggle Switch ON at power-up Fault: Check the wires to the Toggle Switch or look for a stuck Toggle Switch.
18	Pothole Guard Fault: Check that the pothole guards are extended, check the pothole limit switches. Check wires to the switches, check the down limit switch and connections.
31	Pressure Sensor Fault: Check the wiring to the sensor and then the sensor itself. Also check to make sure that the correct option is properly selected (or not) for load sensing.
32	Angle Sensor Fault: Check the wiring to the sensor and then the sensor itself. Also check to make sure that the correct option is properly selected (or not) for load sensing
35	Pressure Sensor 2 Fault: Check the wiring to the sensor and then the sensor itself. Also check to make sure that the correct option is properly selected (or not) for load sensing.
36	Low Voltage Alert: Check battery voltage and charge batteries if necessary.
42	Platform Left Turn Switch ON at power-up Message: Ensure that nothing is holding the Joystick Toggle Switches down. If OK, consider replacing the Joystick or PCU.
43	Platform Right Turn Switch ON at power-up Message: Ensure that nothing is holding the Joystick Toggle Switches down. If OK, consider replacing the Joystick or PCU.
46	Platform Joystick Enable Switch ON at power-up Fault: Ensure that nothing is holding the Enable switch closed. Also check the neutral zone parameters. If OK, consider replacing the Joystick or PCU.
47	Platform Joystick not in neutral at power-up Message: Make sure that the Joystick is in the neutral (upright) position. Check the neutral zone parameter setting in Dingli Scissor Programmer. If it's OK, consider replacing the Joystick or the PCU.
52	Drive Forward Coil Fault: Check the connections to the Coil's terminals and make sure they are tight. If so, check the coil itself to see if it is open or shorted.
53	Drive Reverse Coil Fault: Check the connections to the Coil's terminals and make sure they are tight. If so, check the coil itself to see if it is open or shorted.
54	Lift Up Coil Fault: Check the connections to the Coil's terminals and make sure they are tight. If so, check the coil itself to see if it is open or shorted.

Operating Instructions

Display	Description
55	Lift Down Coil Fault: Check the connections to the Coil's terminals and make sure they are tight. If so, check the coil itself to see if it is open or shorted.
56	Right Turn Coil Fault: Check the connections to the Coil's terminals and make sure they are tight. If so, check the coil itself to see if it is open or shorted.
57	Left Turn Coil Fault: Check the connections to the Coil's terminals and make sure they are tight. If so, check the coil itself to see if it is open or shorted.
58	General Brake Coil Fault: Check the connections to the Coil's terminals and make sure they are tight. If so, check the coil itself to see if it is open or shorted.
59	Parallel Coil Fault: Check the connections to the Coil's terminals and make sure they are tight. If so, check the coil itself to see if it is open or shorted.
60	Motor Controller Fault: Cycle power. If still needed, try replacing the Motor Controller.
61	Motor Controller Current Sensor Fault: Drive or Lift Motor may be overheating. Let the lift cool down. If that does not help, cycle power to reset the Motor controller. If the problem persists, check the wiring and if OK, try replacing the Motor Controller.
62	Motor Controller Hardware Failsafe Fault: Cycle power. If that does not resolve the issue check for noise sources. If still needed, try replacing the Motor Controller.
63	Motor Controller Motor Output fault: Check wiring first then cycle power. If needed replace controller.
64	Motor Controller SRO Fault: Look at motor enable delay with the Dingli Scissor Programmer, it may be too short. Make sure other Motor Controller parameters are properly selected.
65	Motor Controller Throttle Fault: Check wiring. Make sure the correct throttle type is selected in the Motor Controller.
66	Motor Controller Emergency Reverse Fault: Ensure that the Emergency Reverse Check Parameter is off in the Motor Controller.
67	Motor Controller HPD Fault: Look at motor enable delay with the Dingli Scissor Programmer, it may be too short. Make sure other Motor Controller parameters are properly selected.
68	Low Voltage Fault: Check battery voltage and charge batteries if necessary. Check the battery connections and tighten or clean. Check the voltage to the ECU and PCU.
69	High Neutral Current: The MC is sensing current in the motors when there should not be. This could occur anytime the MC thinks the brakes are on and the motors are still turning. This message sometimes comes just before other faults but should be ignored in those cases.
70	Steering Input Out of Range: There is an inappropriate voltage at the steering input of the ZAPI motor controller. The ZAPI may need to be "trained" for the three steering voltages (on Differential Steered machines). Or the steering voltage from the ECU was at some point outside of the range that was recorded during the "training" session. Retrain the controller and/or check for fluctuating voltages due to loose wires, etc.

Operating Instructions

Display	Description
71	Motor Controller Main Contactor Fault: Check the connections to the main contactor. Replace the contactor if necessary. Replace the Motor Controller if necessary.
72	Motor Controller Over Voltage Fault: Check battery voltage and make sure the battery charger is not on. The cycle power to the lift. If that does not resolve the issue, try replacing the Motor Controller.
73	Motor Controller Thermal Cutback Fault: Drive or Lift Motor may be overheating. Let the lift cool down. If that does not help cycle power to reset the Motor controller. If that doesn't resolve the issue, replace the Motor Controller.
74	Motor Controller Motor Fault: Check connections to the motors. Cycle power to the lift and if that does not resolve the issue, replace the Motor Controller.
75	Motor Controller Pump Motor Fault: Check connections to the Pump Motor. Cycle power to the lift and if that does not resolve the issue, replace the Motor Controller.
76	Motor Controller Left Drive Motor Fault: Check connections to the motors. Cycle power to the lift and if that does not resolve the issue, replace the Motor Controller.
77	Motor Controller Right Drive Motor Fault: Check connections to the motors. Cycle power to the lift and if that does not resolve the issue, replace the Motor Controller.
78	Pump Motor Short Fault: Check connections to the pump motor. Cycle power to the lift and if that does not resolve the issue, replace the Motor Controller.
79	Left Drive Motor Short Fault: Check the Motor connections and make sure they are tight. Check the Motor for a short.
80	Over 80% Load Warning: Platform is getting close to its limit of weight. Consider not adding more load.
81	Right Drive Motor Short Fault: Check the Motor connections and make sure they are tight. Check the Motor for a short.
82	Left Brake Coil Fault: Check the connections to the Coil's terminals and make sure they are tight. If so, check the coil itself to see if it is open or shorted.
83	Right Brake Coil Fault: Check the connections to the Coil's terminals and make sure they are tight. If so, check the coil itself to see if it is open or shorted.
84	Motor Post shorted: Check the connections of the controller and motor. Make sure the wiring is not shorted.
85	Brake Release Switch On: Check the wires to brake release switch or look for a stuck switch.
86	Brake Release Not Stowed: Check if the platform is below down limit height. Check the down limit switch and connections.
87	Brake Release Need Switch On: Check the wires to brake release switch or look for a Stuck switch. Check the wires to the Toggle Switch or look for a stuck Toggle Switch.
89	Motor Field Open: The field voltage is different from 1/2 battery voltage. Check connections of the field wires or leakage to the vehicle frame.

Operating Instructions

Display	Description
90	Over 90% Load Warning: Platform is getting close to its limit of weight. Consider not adding more load.
91	Left Motor Field Short: Check connections of the field wires or leakage to the vehicle frame.
92	Right Motor Field Short: Check connections of the field wires or leakage to the vehicle frame.
99	Over 99% Load Warning: Platform has reached its limit of weight. Do not add more load.
OL	Overloaded Platform Fault: Remove the excess load immediately.
LL	Machine Tilted Beyond Safe Limits Fault: If the machine is tilted, find a way to make it level. If the machine is level, check the wiring to the tilt sensor and then the sensor itself.

For more information, please consult the appropriate Dingli Service Dept.

Operating Instructions



Battery and Charger Instructions

Observe and Obey:

- Do not use an external charger or booster battery.
- Charge the battery in a well-ventilated area.
- Use proper AC input voltage for charging as indicated on the charger.
- Use only a Dingli authorized battery and charger.

To Charge Battery

- 1 Be sure the battery is connected before charging.

Maintenance - free battery

- 2 Connect the battery charger to a grounded AC circuit.
- 3 The charger will indicate when the battery is fully charged.

Standard Battery

- 4 Remove the battery vent caps and check the battery acid level. If necessary, add only enough distilled water to cover the plates. Do not overfill prior to the charge cycle.
- 5 Replace the battery vent caps.
- 6 Connect the battery charger to a grounded AC circuit.
- 7 The charger will indicate when the battery is fully charged.

- 8 Check the battery acid level when the charging cycle is complete. Replenish with distilled water to the bottom of the fill tube. Do not overfill.

Dry Battery Filling and Charging Instructions

- 1 Remove the battery vent caps and permanently remove the plastic seal from the battery vent openings.
- 2 Fill each cell with battery acid (electrolyte) until the level is sufficient to cover the plates.

Do not fill to the maximum level until the battery charge cycle is complete. Overfilling can cause the battery acid to overflow during charging. Neutralize battery acid spills with baking soda and water.

- 3 Install the battery vent caps.
- 4 Charge the battery.
- 5 Check the battery acid level when the charging cycle is complete. Replenish with distilled water to the bottom of the fill tube. Do not overfill.

Transport and Lifting Instructions



Observe and Obey:

- Common sense and planning must be applied to control the movement of the machine when lifting it with a crane or forklift.
- Only qualified aerial lift operators should move the machine on or off the truck.
- The transport vehicle must be parked on a level surface.
- The transport vehicle must be secured to prevent rolling while the machine is being loaded.
- Be sure the vehicle capacity, loading surfaces and chains or straps are sufficient to withstand the machine weight. See the serial label for the machine weight.
- The machine must be on a level surface or secured before releasing the brakes.
- Only qualified forklift operators should lift the machine with a forklift.
- Be sure the crane capacity, loading surfaces and straps or lines are sufficient to withstand the machine weight. See the serial plate for the machine weight.

Brake Release Operation

- 1 Chock the wheels to prevent the machine from rolling.
- 2 Pull out the red Emergency Stop button on both the ground and platform controls to the on position.
- 3 Press the brake release switch to on position.
- 4 Press and hold lift switch to "down" position in ground control, meanwhile turn on the key switch to the "Ground" position. The brake will be released after Alarm alerts.
- 5 If you want to close the brake release, just turn off the key switch in "ground" position.
- 6 Push the red Emergency stop button on both the ground and platform controls to the off position.

The machine must be towed, do not exceed 4km/h.

Transport and Lifting Instructions

Securing to Truck or Trailer for Transit

Always chock the machine wheels in preparation for transport.

Retract and secure the extension deck(s).

Turn the key switch to the off position and remove the key before transporting.

Inspect the entire machine for loose or unsecured items.

Use the tie-down points on the chassis for anchoring down to the transport surface.

Use a minimum of four chains or straps.

Use chains or straps of ample load capacity.

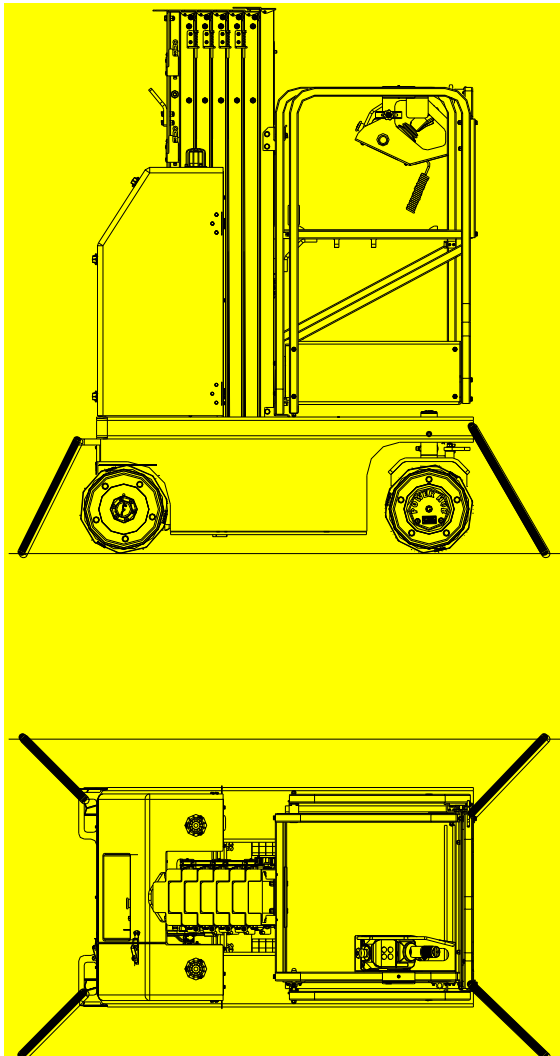

Lifting the Machine with a Forklift

Be sure the extension deck, controls and component trays are secure. Remove all loose items on the machine.

Fully lower the platform. The platform must remain lowered during all loading and transport procedures.

Use the forklift pockets located on both sides of the driving wheels.

Position the forklift forks in position with the forklift pockets.

Drive forward to the full extent of the forks.

Raise the machine 6 in / 15 cm and then tilt the forks back slightly to keep the machine secure.

Be sure the machine is level when lowering the forks.

NOTICE

Lifting the machine from the side can result in component damage.

Maintenance



Observe and Obey:

- ✓ Only routine maintenance items specified in this manual shall be performed by the operator.
- ✓ Scheduled maintenance inspections shall be completed by qualified service technicians, according to the manufacturer's specifications and the requirements specified in this manual.

Maintenance Symbols Legend

NOTICE The following symbols have been used in this manual to help communicate the intent of the instructions. When one or more of the symbols appear at the beginning of a maintenance procedure, it conveys the meaning below.



Indicates that tools will be required to perform this procedure.



Indicates that new parts will be required to perform this procedure.



Indicates that dealer service will be required to perform this procedure.

Pre-delivery Preparation Report

The pre-delivery preparation report contains checklists for each type of scheduled inspection.

Make copies of the Pre-delivery Preparation report to use for each inspection. Store completed forms as required.

Maintenance Schedule

There are five types of maintenance inspections that must be performed according to a schedule— daily, quarterly, semi-annually, annually, and two year. The Scheduled Maintenance Procedures Section and the Maintenance Inspection Report have been divided into five subsections—A, B, C, D, and E. Use the following chart to determine which group(s) of procedures are required to perform a scheduled inspection.

Inspection	Checklist
Daily or every 8 hours	A
Quarterly or every 250 hours	A+B
Semi-annually or every 500 hours	A+B+C
Annually or every 1000 hours	A+B+C+D
Two year or every 2000 hours	A+B+C+D+E

Maintenance Inspection Report

The maintenance inspection report contains checklists for each type of scheduled inspection.

Make copies of the Maintenance Inspection Report to use for each inspection. Maintain completed forms for a minimum of 4 years or in compliance with your employer, jobsite and governmental regulations and requirements.

Maintenance

Pre-delivery Preparation Report

Fundamentals

It is the responsibility of the dealer to perform the Pre-delivery Preparation.

The Pre-delivery Preparation is performed prior to each delivery. The inspection is designed to discover if anything is apparently wrong with a machine before it is put into service.

A damaged or modified machine must never be used. If damage or any variation from factory delivered condition is discovered, the machine must be tagged and removed from service.

Repairs to the machine may only be made by a qualified service technician, according to the manufacturer's specifications.

Scheduled maintenance inspections shall be performed by qualified service technicians, according to the manufacturer's specifications and the requirements listed in this manual.

Instructions

Use the operator's manual on your machine.

The Pre-delivery Preparation consists of completing the Pre-operation Inspection, the Maintenance items and the Function Tests.

Use this form to record the results. Place a check in the appropriate box after each part is completed. Follow the instructions in the operator's manual.

If any inspection receives an N, remove the machine from service, repair and re-inspect it. After repair, place a check in the R box.

Legend

Y = yes, completed

N = no, unable to complete

R = repaired

Comments

Pre-Delivery Preparation	Y	N	R
Pre-operation inspection completed			
Maintenance items completed			
Function tests completed			

Model

Serial number

Date

Machine owner

Inspected by (print)

Inspector signature

Inspector title

Inspector company

Maintenance

Maintenance Inspection Report

Model
Serial number
Date
Hour meter
Machine owner
Inspected by (print)
Inspector signature
Inspector title
Inspector company

Instructions

- Make copies of this report to use for each inspection.
- Select the appropriate checklist(s) for the type of inspection to be performed.

<input type="checkbox"/> Daily or 8 hours Inspection:	A
<input type="checkbox"/> Quarterly or 250 hours Inspection:	A+ B
<input type="checkbox"/> Semi-annually or 500 hours Inspection:	A+B+C
<input type="checkbox"/> Annually or 1000 hours Inspection:	A+B+C+D

- Place a check in the appropriate box after each inspection procedure is completed.
- Use the step-by-step procedures in this section to learn how to perform these inspections.
- If any inspection receives an "N", tag and remove the machine from service, repair and re-inspect it. After repair, place a check in the "R" box.

Legend

- Y = yes, acceptable
- N = no, remove from service
- R = repaired

Checklist A	Y	N	R
A-1 Inspect the manuals and decals			
A-2 Pre-operation inspection			
A-3 Function tests			

Perform after 40 hours:

A-4 30 day service			
--------------------	--	--	--

Perform every 100 hours:

A-5 Grease steer yokes			
------------------------	--	--	--

Checklist B	Y	N	R
B-1 Batteries			
B-2 Electrical wiring			
B-3 Tires and wheels			
B-4 Emergency stop			
B-5 Lifting Chains			
B-6 Clean and Lubricate the Columns			
B-7 Test the up limit switches			
B-8 Key switch			
B-9 Horn			
B-10 Drive brakes			
B-11 Drive speed - stowed			
B-12 Drive speed - raised			
B-13 Hydraulic oil analysis			
B-14 Tank venting system			
B-15 wire ropes system			

Checklist C	Y	N	R
C-1 Platform overload			
C-2 Breather cap - models with optional oil			

Checklist D	Y	N	R
D-1 Hydraulic oil			

Checklist A Procedures

A-1

Inspect the Manuals and Decals

Maintaining the operator's manual in good condition is essential to safe machine operation. Manuals are included with each machine and should be stored in the container provided in the platform. An illegible or missing manual will not provide safety and operational information necessary for a safe operating condition.

In addition, maintaining all of the safety and instructional decals in good condition is mandatory for safe machine operation. Decals alert operators and personnel to the many possible hazards associated with using this machine. They also provide users with operation and maintenance information. An illegible decal will fail to alert personnel of a procedure or hazard and could result in unsafe operating conditions.

- 1 Check to make sure that the operator manual is present and complete in the storage container on the platform.
 - 2 Examine the pages of manual to be sure that they are legible and in good condition.
- ☉ Result: The operator manual is appropriate for the machine and the manual are legible and in good condition.
 - ☒ Result: The operator's manual is not appropriate for the machine or the manual is not in good condition or is illegible. Remove the machine from service until the manual is replaced.
- 3 Open the operator's manual to the decals inspection section. Carefully and thoroughly inspect all decals on the machine for legibility and damage.

- ☉ Result: The machine is equipped with all required decals, and all decals are legible and in good condition.
 - ☒ Result: The machine is not equipped with all required decals, or one or more decals are illegible or in poor condition. Remove the machine from service until the decals are replaced.
- 4 Always return the manual to the storage container after use.

Note: Contact your authorized DINGLI distributor or DINGLI Industries if replacement manuals or decals are needed.

Maintenance

A-2

Perform Pre-operation Inspection

Completing a Pre-operation Inspection is essential to safe machine operation. The Pre-operation Inspection is a visual inspection performed by the operator prior to each work shift. The inspection is designed to discover if anything is apparently wrong with a machine before the operator performs the function tests. The Pre-operation Inspection also serves to determine if routine maintenance procedures are required.

Complete information to perform this procedure is available in the appropriate operator's manual. Refer to the Operator's Manual on your machine.

A-3

Perform Function Tests

Completing the function tests is essential to safe machine operation. Function tests are designed to discover any malfunctions before the machine is put into service. A malfunctioning machine must never be used. If malfunctions are discovered, the machine must be tagged and removed from service.

Complete information to perform this procedure is available in the appropriate operator's manual. Refer to the Operator's Manual on your machine.

Maintenance

A-4

Perform 30 Day Service



The 30 day maintenance procedure is a one time procedure to be performed after the first 30 days or 40 hours of usage. After this interval, refer to the maintenance tables for continued scheduled maintenance.

- 1 Perform the following maintenance procedures:
 - B-3 Inspect the Tires and Wheels.

A-5

Grease the Steer Yokes



DINGLI requires that this procedure be performed every 100 hours of operation.

Regular application of lubrication to the steer yokes is essential to good machine performance and service life. Continued use of an insufficiently greased steer yoke will result in component damage.

- 1 Open the steer yoke cover.
- 2 Pump multipurpose grease into the steer yoke until the steer yoke is full and grease is being forced past the bearings.
- 3 Install the cover.
- 4 Repeat this step for the other steer yoke.

Grease Specification

Chevron Ultra-duty grease, EP NLGI 1 (lithium based) or equivalent

Maintenance

Checklist B Procedures

B-1

Inspect the Batteries



DINGLI requires that this procedure be performed every 250 hours or quarterly, whichever comes first.

Proper battery condition is essential to good machine performance and operational safety. Improper fluid levels or damaged cables and connections can result in component damage and hazardous conditions.

⚠ WARNING Electrocutation / burn hazard. Contact with electrically charged circuits could result in death or serious injury. Remove all rings, watches and other jewelry.

⚠ WARNING Bodily injury hazard. Batteries contain acid. Avoid spilling or contacting battery acid. Neutralize battery acid spills with baking soda and water.

- 1 Put on protective clothing and eye wear.
- 2 Be sure that the battery cable connections are free of corrosion.

Note: Adding terminal protectors and a corrosion preventative sealant will help eliminate corrosion on the battery terminals and cables.

- 3 Be sure that the battery retainers and cable connections are tight.
- 4 Fully charge the batteries. Allow the batteries to rest 24 hours before performing this procedure to allow the battery cells to equalize.

Models without maintenance-free or sealed batteries:

- 5 Remove the battery vent caps and check the specific gravity of each battery cell with a hydrometer. Note the results.
- 6 Check the ambient air temperature and adjust the specific gravity reading for each cell as follows:
 - Add 0.004 to the reading of each cell for every 5.5° C above 26.7° C.
 - Subtract 0.004 from the reading of each cell for every 5.5° C below 26.7° C.
- ⊙ Result: All battery cells display an adjusted specific gravity of 1.277 or higher. The battery is fully charged. Proceed to step 10.
- ⊖ Result: One or more battery cells display a specific gravity of 1.217 or below. Proceed to step 7.
- 7 Perform an equalizing charge OR fully charge the batteries and allow the batteries to rest at least 6 hours.
- 8 Remove the battery vent caps and check the specific gravity of each battery cell with a hydrometer. Note the results.
- 9 Check the ambient air temperature and adjust the specific gravity reading for each cell as follows:
 - Add 0.004 to the reading of each cell for every 5.5° C above 26.7° C.
 - Subtract 0.004 from the reading of each cell for every 5.5° C below 26.7° C.
- ⊙ Result: All battery cells display a specific gravity of 1.277 or greater. The battery is fully charged. Proceed to step 10.

Maintenance

⊖ Result: The difference in specific gravity readings between cells is greater than 0.1 OR the specific gravity of one or more cells is less than 1.177. Replace the battery.

10 Check the battery acid level. If needed, replenish with distilled water to 3 mm below the bottom of the battery fill tube. Do not overfill.

11 Install the vent caps and neutralize any electrolyte with baking soda and water that may have spilled.

All models:

12 Check each battery pack and verify that the batteries are wired correctly.

13 Inspect the battery charger plug and pigtail for damage or excessive insulation wear. Replace as required.

14 Connect the battery charger to a properly grounded 110 - 230V / 50 – 60 Hz single phase AC power supply.

⊕ Result: The charger should operate and begin charging the batteries.

⊖ Result: If, simultaneously, the charger alarm sounds and the LEDs blink, correct the charger connections at the fuse and battery. The charger will then operate correctly and begin charging the batteries.

Note: For best results, use an extension of adequate size with a length no longer than 15m.

Note: If you have any further questions regarding the battery charger operation, please contact the DINGLI Service Department.

B-2**Inspect the Electrical Wiring**

DINGLI requires that this procedure be performed every 250 hours or quarterly, whichever comes first.

Maintaining electrical wiring in good condition is essential to safe operation and good machine performance. Failure to find and replace burnt, chafed, corroded or pinched wires could result in unsafe operating conditions and may cause component damage.

⚠ WARNING Electrocutation / burn hazard. Contact with electrically charged circuits could result in death or serious injury. Remove all rings, watches and other jewelry.

- 1 Inspect the underside of the chassis for damaged or missing ground strap(s).
- 2 Inspect the following areas for burnt, chafed, corroded and loose wires:
 - Mast cable
 - Platform controls
 - Power to platform wiring
 - Ground control panel
 - Hydraulic power unit module cable
- 3 Turn the key switch to ground control and pull out the red Emergency Stop button to the on position at both the ground and platform controls.
- 4 Raise the platform approximately 2 m from the ground.
- 5 Place a lifting strap from an overhead crane under the platform. Support the platform. Do not apply any lifting pressure.

Maintenance

⚠ WARNING Component damage hazard.

The platform railings can be damaged if they are used to lift the platform. Do not attach the lifting strap to the platform railings.

- 6 Inspect for a liberal coating of dielectric grease in the following locations:
 - Between the ECU and platform controls
 - All wire harness connectors tilt sensor
- 7 Open the cover.
- 8 Inspect the battery tray for burnt, chafed and pinched cables.
- 9 Close the battery tray cover.
- 10 Remove the strap from the platform.
- 11 Lower the platform to the stowed position and turn the machine off.

B-3

Inspect the Tires and Wheels (including castle nut torque)



DINGLI requires that this procedure be performed every 250 hours or quarterly, whichever comes first.

Maintaining the tires and wheels in good condition is essential to safe operation and good performance. Tire and/or wheel failure could result in a machine tip-over. Component damage may also result if problems are not discovered and repaired in a timely fashion.

- 1 Check the tire surface and sidewalls for cuts, cracks, punctures and unusual wear.
- 2 Check each wheel for damage, bends and cracks.

B-4**Test the Emergency Stop**

DINGLI requires that this procedure be performed every 250 hours or quarterly, whichever comes first.

A properly functioning Emergency Stop is essential for safe machine operation. An improperly operating red Emergency Stop button will fail to shut off power and stop all machine functions, resulting in a hazardous situation.

As a safety feature, selecting and operating the ground controls will override the platform controls, except the platform red Emergency Stop button.

- 1 Turn the key switch to ground control and pull out the red Emergency Stop button to the on position at both the ground and platform controls.
 - 2 Push in the red Emergency Stop button at the ground controls to the off position.
- ⊙ Result: No machine functions should operate.
- 3 Turn the key switch to platform control and pull out the red Emergency Stop button to the on position at both the ground and platform controls.
 - 4 Push down the red Emergency Stop button at the platform controls to the off position.
- ⊙ Result: No machine functions should operate.

Note: The red Emergency Stop button at the ground controls will stop all machine operation, even if the key switch is switched to platform control.

B-5**Lubricate the Lifting Chains**

Lubricated chains are essential to good machine performance and safe operation. Extremely dirty conditions may require that the chains be cleaned and lubricated more often.

The direct result of wearing the transmission chain is to stretch the total length of the chain. Measure the stretching rate of the used transmission chain by eye every three months. The mast connected to the elongated chain would be lower in position so that the top of each mast is obviously uneven in 'stored' position. It may lead to damage on guide roller if the problem is serious.

NOTICE

Every link of the transmission chain is associated with three links of the masts.

- 1 Lower the platform to the stowed position.
 - 2 Measure the maximum height of the machine.
- ⊙ Result: The machine should be no lower than specification.
- ⊗ Result: The machine should be lower than specification.

The following sketch shows the connection of the masts and the transmission chain.

Maintenance

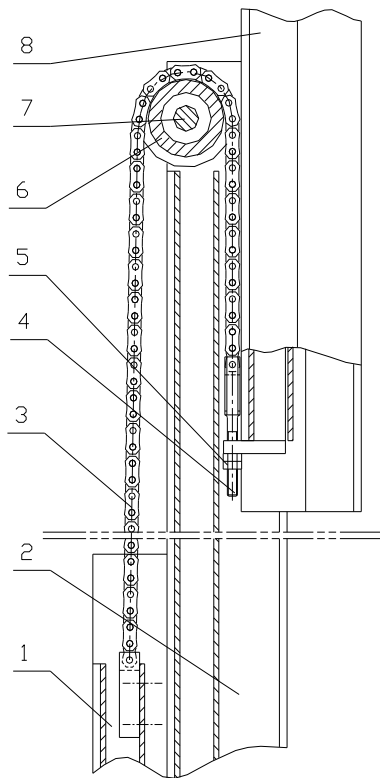

- 1-next link of the mast;
- 2-the middle link of the mast;
- 3-the transmission chain;
- 4-adjusting bolt;
- 5-adjusting lock nut;
- 6-chainwheel;
- 7-chainwheel shaft;
- 8-the last link of the mast

- 3 When regulating the length of the chain, please select the mast that needs increasing its height. As shown in the sketch, regulating the nut 5 tightly makes the last link of the mast 8 move upwards. The dual nuts 5 should be connected with each other tightly after regulating the length of the chain.
- 4 The same link of the mast is pulled by two chains and endures the raised weight loads at the same time. If one of the chains loses efficacy, the other will play an

important safety role; therefore, try to make both chains as loose or tight as consistent each other when regulating the length of the chain. The methods of judge at site are as follows: Press the two chains by hands to compare their tautness under lifting status.

⚠ WARNING Make sure the chock is in place during maintenance

⚠ WARNING When the work platform of a AMWP needs to be raised for routine servicing purposes, a captive chock shall be used to enable the extending structure to be held in the required position to prevent work platform.



Maintenance

B-6

Clean and Lubricate the Columns



Clean and properly lubricated columns are essential to good machine performance and safe operation. Extremely dirty conditions may require that the columns be cleaned and lubricated more often.

- 1 Raise the platform to the maximum height.
- 2 Visually inspect the inner and outer channels of the columns for debris or foreign material. If necessary, use a mild cleaning solvent to clean the columns.
- 3 The bearing between chain wheel with the shaft is lubricated with the calcium base grease in raising.
- 4 Lubricate the place between chain wheel with chain used grease gun.
- 5 Lubricate the lead rail with the calcium base grease in raising.

⚠ WARNING This procedure will require the use of additional access equipment. Do not place ladders or scaffold on or against any part of the machine. Performing this procedure without the proper skills and tools may result in death or serious injury. Dealer service is strongly recommended.

B-7

Test the Up Limit Switch



Maintaining the limit switches is essential to safe operation and good machine performance.

Operating the machine with a faulty limit switch could result in reduced machine performance and a potentially unsafe operating condition.

Perform these procedures with the machine on a firm, level surface that is free of obstructions.

- 1 Turn the key switch to ground control
- 2 While raising the platform from the ground controls, push in the roller of the up limit switch to activate the limit switch.

☉ Result: The platform stops raising. The machine is functioning properly.

☐ Result: The platform continues to raise. Adjust or replace the up limit switch.

Maintenance

B-8

Test the Key Switch

DINGLI requires that this procedure be performed every 250 hours or quarterly, whichever comes first.

Proper key switch action and response is essential to safe machine operation. The machine can be operated from the ground or platform controls and the activation of one or the other is accomplished with the key switch. Failure of the key switch to activate the appropriate control panel could cause a hazardous operating situation.

Perform this procedure from the ground using the platform controls. Do not stand in the platform.

- 1 Pull out the red Emergency Stop button to the on position at both the ground and platform controls.
 - 2 Turn the key switch to platform control.
 - 3 Check the platform up/down function from the ground controls.
- ⊙ Result: The machine functions should not operate.
- 4 Turn the key switch to ground control.
 - 5 Check the machine functions from the platform controls.
- ⊙ Result: The machine functions should not operate.
- 6 Turn the key switch to the off position.
- ⊙ Result: No function should operate.

B-9

Test the Automotive-style Horn

DINGLI requires that this procedure be performed every 250 hours or quarterly, whichever comes first.

The horn is activated at the platform controls and sounds at the ground as a warning to ground personnel. An improperly functioning horn will prevent the operator from alerting ground personnel of hazards or unsafe conditions.

- 1 Turn the key switch to platform control and pull out the red Emergency Stop button to the on position at both the ground and platform controls.
 - 2 Push down the horn button at the platform controls.
- ⊙ Result: The horn should sound.

B-10**Test the Drive Brakes**

DINGLI requires that this procedure be performed every 250 hours or quarterly, whichever comes first.

Proper brake action is essential to safe machine operation. The drive brake function should operate smoothly, free of hesitation, jerking and unusual noise. Released individual wheel brakes can appear to operate normally when not fully operational.

Perform this procedure with the machine on a firm level surface that is free of obstructions, with the platform extension deck fully retracted and the platform in the stowed position.

- 1 Mark 2 test lines those are on the ground for reference.
- 2 Turn the key switch to platform control and pull out the red Emergency Stop button to the on position at both the ground and platform controls.
- 3 Lower the platform to the stowed position.
- 4 Press the drive function select button.

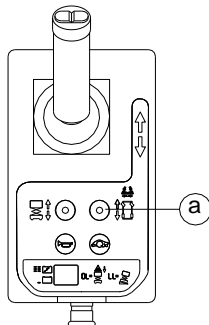

a drive function select button

- 5 Choose a point on the machine; i.e., contact patch of a tire, as a visual reference for use when crossing the test line.

- 6 Bring the machine to top drive speed before reaching the test line. Release the function enable switch or the joystick when your reference point on the machine crosses the test line.
- 7 Measure the distance between the test line and your machine reference point.
 - ⊙ Result: The machine stops within the specified braking distance. No action required.
 - ⊗ Result: The machine does not stop within the specified braking distance.

Note: The brakes must be able to hold the machine on any slope it is able to climb.

- 8 Replace the brakes and repeat this procedure beginning with step 1.

Braking distance, maximum

High range on paved surface 61cm ± 30cm

Maintenance

B-11

Test the Drive Speed - Stowed Position



DINGLI requires that this procedure be performed every 250 hours or quarterly, whichever comes first.

Proper drive functions are essential to safe machine operation. The drive function should respond quickly and smoothly to operator control. Drive performance should also be free of hesitation, jerking and unusual noise over the entire proportionally controlled speed range.

Perform this procedure with the machine on a firm, level surface that is free of obstructions.

- 1 Create start and finish lines by marking two lines on the ground 12.2 m apart.
- 2 Turn the key switch to platform control and pull out the red Emergency Stop button to the on position at both the ground and platform controls.
- 3 Lower the platform to the stowed position.
- 4 Press the drive function select button.
- 5 Choose a point on the machine; i.e., contact patch of a tire, as a visual reference for use when crossing the start and finish lines.
- 6 Bring the machine to top drive speed before reaching the start line. Begin timing when your reference point on the machine crosses the start line.
- 7 Continue at full speed and note the time when your reference point on the machine passes over the finish line. Refer to specifications.

B-12

Test the Drive Speed - Raised Position



DINGLI requires that this procedure be performed every 250 hours or quarterly, whichever comes first.

Proper drive functions are essential to safe machine operation. The drive function should respond quickly and smoothly to operator control. Drive performance should also be free of hesitation, jerking and unusual noise over the entire proportionally controlled speed range.

Perform this procedure with the machine on a firm, level surface that is free of obstructions.

- 1 Create start and finish lines by marking two lines on the ground 12.2 m apart.
- 2 Turn the key switch to platform control and pull out the red Emergency Stop button to the on position at both the ground and platform controls.
- 3 Press the lift function select button.

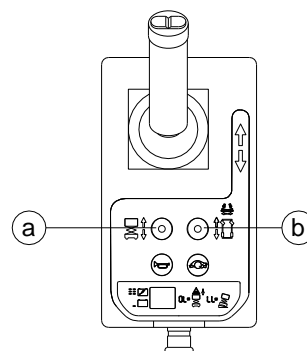

- a lift function select button
- b drive function select button

- 4 Press and hold the function enable switch on the joystick.
- 5 Raise the platform approximately 1.2 m from the ground.

Maintenance

- 6 Press the drive function select button.
- 7 Choose a point on the machine; i.e., contact patch of a tire, as a visual reference for use when crossing the start and finish lines.
- 8 Bring the machine to top drive speed before reaching the start line. Begin timing when your reference point on the machine crosses the start line.
- 9 Continue at full speed and note the time when your reference point on the machine passes over the finish line. Refer to specifications.

B-13

Perform Hydraulic Oil Analysis



DINGLI requires that this procedure be performed every 250 hours or quarterly, whichever comes first.

Replacement or testing of the hydraulic oil is essential for good machine performance and service life. Dirty oil may cause the machine to perform poorly and continued use may cause component damage. Extremely dirty conditions may require oil changes to be performed more often.

Before replacing the hydraulic oil, the oil may be tested by an oil distributor for specific levels of contamination to verify that changing the oil is necessary.

If the hydraulic oil is not replaced at the two year inspection, test the oil quarterly. Replace the oil when it fails the test. See D-1, Test or Replace the Hydraulic Oil.

Maintenance

B-14

Inspect the Hydraulic Tank Cap Venting System



DINGLI requires that this procedure be performed quarterly or every 250 hours, whichever comes first. Perform this procedure more often if dusty conditions exist.

A free-breathing hydraulic tank cap is essential for good machine performance and service life. A dirty or clogged cap may cause the machine to perform poorly. Extremely dirty conditions may require that the cap be inspected more often.

- 1 Open the cover.
 - 2 Remove the breather cap from the hydraulic tank.
 - 3 Check for proper venting.
- Result: Air passes through the breather cap.
- Result: If air does not pass through the cap, clean or replace the cap. Proceed to step 4.

Note: When checking for positive tank cap venting, air should pass freely through the cap.

- 4 Using a mild solvent, carefully wash the cap venting system. Dry using low pressure compressed air. Repeat step 3.
- 5 Install the breather cap onto the hydraulic tank.
- 6 Install the cover.

B-15

Inspect the system of wire ropes

Maintaining the system of wire ropes in good condition can reduce risk effectively after chains break.

- 1 Raise the platform approximately 2 m
- 2 Visually inspect condition of every wire rope and both ends:
 - Excessive corrosion or contamination
 - Untightened wire ropes
 - Deformed seat plates
 - Missing or damaged related components
- 3 Inspect the chain terminations near the bottom of each column to confirm that each seat plate has a lock nut.

Checklist C Procedures

C-1

Test the Platform Overload System (if equipped)



DINGLI requires that this procedure be performed every 500 hours or six months, whichever comes first or when the machine occurs overload fault.

Testing the platform overload system regularly is essential to safe machine operation. Continued use of an improperly operating platform overload system could result in the system not sensing an overloaded platform condition. Machine stability could be compromised resulting in the machine tipping over.

⚠ WARNING Perform this procedure with the machine on a firm, level surface.

- 1 Turn the key switch to platform control and pull out the red Emergency Stop button to the on position at both the ground and platform controls.
 - ⊙ Result: The overload alarm at the platform controls should not sound, indicating a normal condition.
 - ⊗ Result: The overload alarm at the platform controls sounds. Calibrate the platform overload system.
- 2 Determine the maximum platform capacity.
- 3 Using a suitable lifting device, place an appropriate test weight equal to the maximum platform capacity in the center of the platform floor.
 - ⊙ Result: The overload alarm at the platform controls should not sound, indicating a normal condition.
 - ⊗ Result: The overload alarm at the platform controls sounds. Calibrate the platform overload system.
- 4 Add an additional weight to the platform not to exceed 10% of the maximum rated load.
 - ⊙ Result: The overload alarm at the platform controls sound, indicating a normal condition.
 - ⊗ Result: The overload alarm at the platform controls does not sound. Calibrate the platform overload system.
- 5 Test all machine functions from the platform controls.
 - ⊙ Result: All platform control functions should not operate.
- 6 Turn the key switch to ground control.
- 7 Test all machine functions from the ground controls
 - ⊙ Result: All ground control functions should not operate.
- 8 Lift the test weight off the platform floor using a suitable lifting device.
 - ⊙ Result: The overload alarm at the platform controls should not sound, indicating a normal condition.
 - ⊗ Result: The overload alarm at the platform controls sounds. Calibrate the platform overload system.
- 9 Test all machine functions from the ground controls.
 - ⊙ Result: All ground control functions should operate.
- 10 Turn the key switch to platform control.
- 11 Test all machine functions from the platform controls.
 - ⊙ Result: All platform control functions should operate.

Maintenance

C-2

Replace the Hydraulic Tank Breather Cap



DINGLI requires that this procedure be performed every 500 hours or semi-annually, whichever comes first.

The hydraulic tank is a vented-type tank. The breather cap has an internal air filter that can become clogged or, over time, can deteriorate. If the breather cap is faulty or improperly installed, impurities can enter the hydraulic system which may cause component damage. Extremely dirty conditions may require that the cap be inspected more often.

- 1 Open the cover.
- 2 Remove and discard the hydraulic tank breather cap.
- 3 Install a new cap onto the tank.
- 4 Install the cover

Checklist D Procedure

D-1

Test or Replace the Hydraulic Oil



DINGLI requires that this procedure be performed every 1000 hours or every one year, whichever comes first.

Replacement or testing of the hydraulic oil is essential for good machine performance and service life. Dirty oil may cause the machine to perform poorly and continued use may cause component damage. Extremely dirty conditions may require oil changes to be performed more often.

Before replacing the hydraulic oil, the oil may be tested by an oil distributor for specific levels of contamination to verify that changing the oil is necessary.

If the hydraulic oil is not replaced at the two year inspection, test the oil quarterly. Replace the oil when it fails the test.

Note: Perform this procedure with the platform in the stowed position.

- 1 Disconnect the battery pack from the machine.
- 2 Fully lower the platform.

⚠ WARNING Electrocutation / burn hazard. Contact with electrically charged circuits could result in death or serious injury. Remove all rings, watches and other jewelry.

- 3 Remove the cover.
- 4 Tag and disconnect the hydraulic pump outlet line and remove the line from the pump. Cap the fitting on the pump.
- 5 Loosen the bolt and remove the tank from the tray.
- 6 Remove the tank.

- 7 Drain all of the oil into a suitable container.

⚠ WARNING Bodily injury hazard.

Spraying hydraulic oil can penetrate and burn skin. Loosen hydraulic connections very slowly to allow the oil pressure to dissipate gradually. Do not allow oil to squirt or spray.

- 8 Clean up any oil that may have spilled. Properly discard the used oil.
- 9 Clean the inside of the hydraulic tank using a mild solvent. Allow the tank to dry completely.
- 10 Install the hydraulic tank and install and tighten the hydraulic tank retaining fasteners. Torque to specification.

Torque specifications

Hydraulic tank retaining fasteners, dry	4 Nm
Hydraulic tank retaining fasteners, lubricated	2.9Nm

- 11 Install the hydraulic power pack into the tray. Install the fitting and hydraulic hoses onto the hydraulic power pack and torque.
- 12 Fill the tank with hydraulic oil until the fluid is full in the hydraulic tank. Do not overfill.
- 13 Activate the pump to fill the hydraulic system with oil and bleed the system of air.

⚠ WARNING Component damage hazard. The pump can be damaged if operated without oil. Be careful not to empty the hydraulic tank while in the process of filling the hydraulic system. Do not allow the pump to cavitate.

Schematic

Hydraulic Schematic

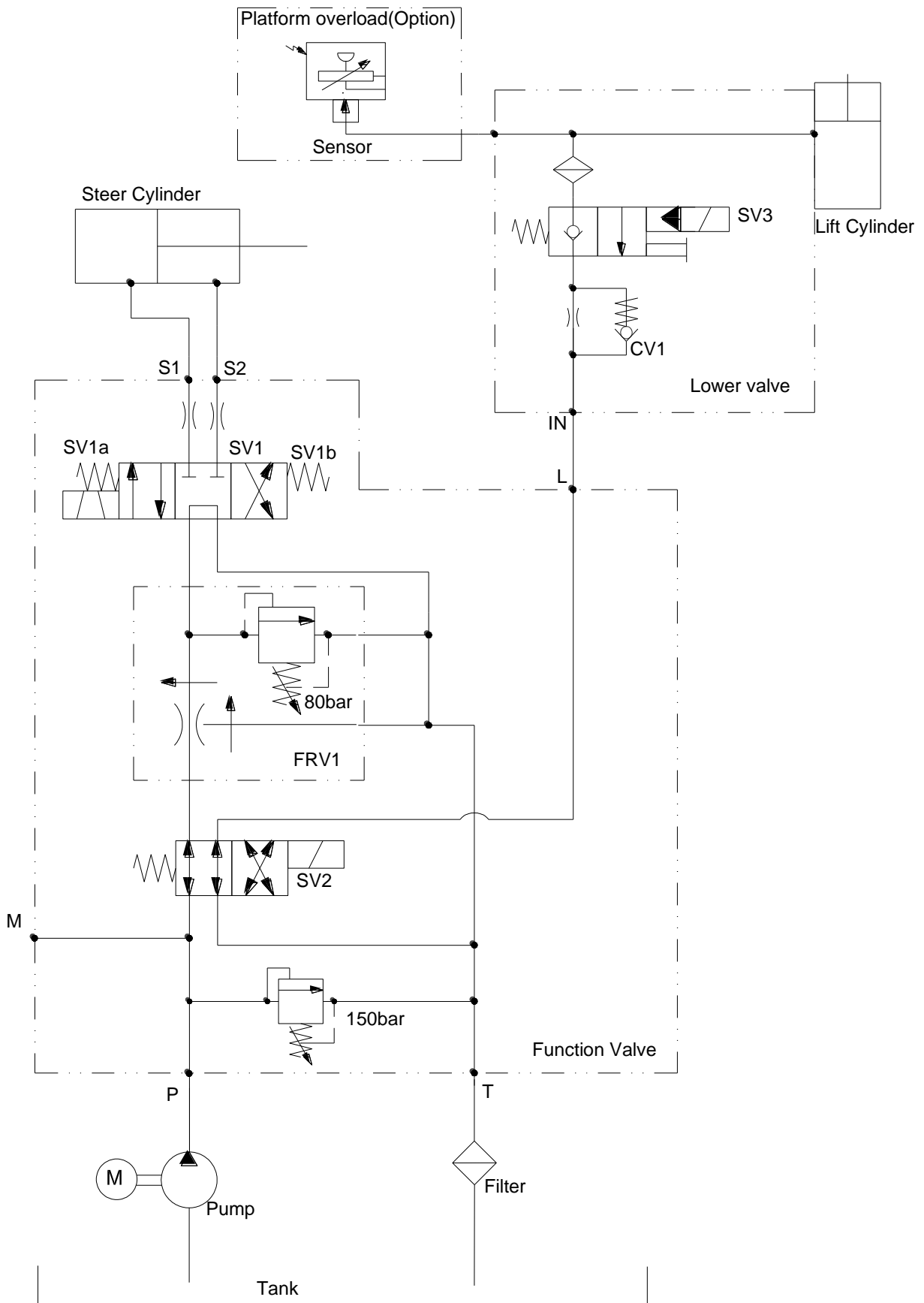

Electrical Schematic

