



Operator's Manual

Serial Number Range

ZX-135/70

from ZX13515-2559

with Jib-Extend™



**ADVANCED
ACCESS PLATFORMS**

CE

with
Maintenance
Information

Original Instructions
Second Edition
Third Printing
Part No. 1258936

Contents

Introduction	1
Symbol and Hazard Pictorials Definitions.....	4
General Safety	6
Personal Safety.....	9
Work Area Safety	10
Legend	18
Controls.....	19
Inspections	28
Operating Instructions.....	46
Transport and Lifting Instructions	55
Maintenance	58
Specifications.....	62

Copyright © 2011 by Terex Corporation

Second Edition: Third Printing, September 2015

Genie and "ZX" are registered trademarks of Terex South Dakota, Inc. in the U.S.A. and many other countries.

 Complies with EC Directive 2006/42/EC
See EC Declaration of Conformity

Introduction

About this manual

Genie appreciates your choice of our machine for your application. Our number one priority is user safety, which is best achieved by our joint efforts. This book is an operation and daily maintenance manual for the user or operator of a Genie machine.

This manual should be considered a permanent part of your machine and should remain with the machine at all times. If you have any questions, contact Genie.

Product Identification

The machine serial number is located on the serial label.

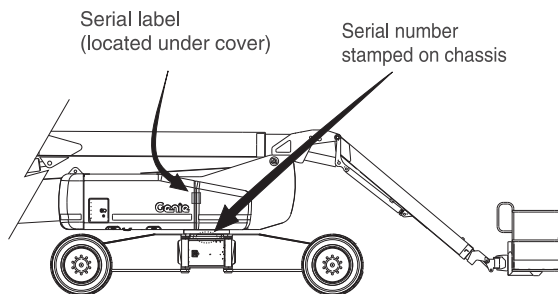

Intended Use

This machine is intended to be used only to lift personnel, along with their tools and materials to an aerial work site.

Bulletin Distribution and Compliance

Safety of product users is of paramount importance to Genie. Various bulletins are used by Genie to communicate important safety and product information to dealers and machine owners.

The information contained in the bulletins is tied to specific machines using the machine model and serial number.

Distribution of bulletins is based on the most current owner on record along with their associated dealer, so it is important to register your machine and keep your contact information up to date.

To ensure safety of personnel and the reliable continued operation of your machine, be sure to comply with the action indicated in a respective bulletin.

Introduction

Contacting the Manufacturer

At times it may be necessary to contact Genie. When you do, be ready to supply the model number and serial number of your machine, along with your name and contact information. At minimum, Genie should be contacted for:

Accident reporting

Questions regarding product applications and safety

Standards and regulatory compliance information

Current owner updates, such as changes in machine ownership or changes in your contact information. See Transfer of Ownership, below.

Transfer of Machine Ownership

Taking a few minutes to update owner information will ensure that you receive important safety, maintenance and operating information that applies to your machine.

Please register your machine by visiting us on the web at www.genielift.com or by calling us toll free at 1-800-536-1800.



Danger

Failure to obey the instructions and safety rules in this manual will result in death or serious injury.

Do Not Operate Unless:

- You learn and practice the principles of safe machine operation contained in this operator's manual.
 - 1 Avoid hazardous situations.**
Know and understand the safety rules before going on to the next section.
 - 2 Always perform a pre-operation inspection.
 - 3 Always perform function tests prior to use.
 - 4 Inspect the workplace.
 - 5 Only use the machine as it was intended.
- You read, understand and obey the manufacturer's instructions and safety rules—safety and operator's manuals and machine decals.
- You read, understand and obey employer's safety rules and worksite regulations.
- You read, understand and obey all applicable governmental regulations.
- You are properly trained to safely operate the machine.

Introduction

Safety Sign Maintenance

Replace any missing or damaged safety signs. Keep operator safety in mind at all times. Use mild soap and water to clean safety signs. Do not use solvent-based cleaners because they may damage the safety sign material.

Hazard Classification

Decals on this machine use symbols, color coding and signal words to identify the following:



Safety alert symbol—used to alert you to potential personal injury hazards. Obey all safety messages that follow this symbol to avoid possible injury or death.

DANGER

Indicates a hazardous situation which, if not avoided, will result in death or serious injury.

WARNING

Indicates a hazardous situation which, if not avoided, could result in death or serious injury.

CAUTION

Indicates a hazardous situation which, if not avoided, could result in minor or moderate injury.











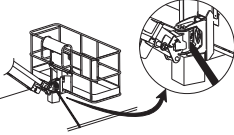
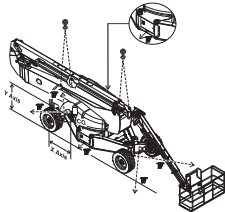

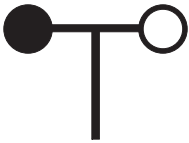
NOTICE

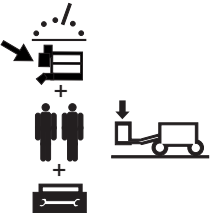
Indicates a property damage message.

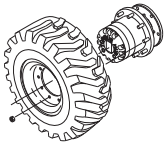
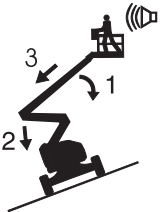
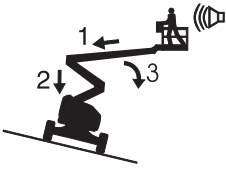
Symbol and Hazard Pictorials Definitions

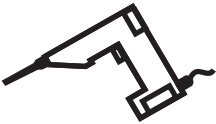
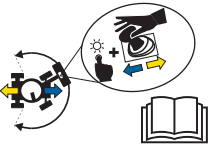
				
Crush hazard	Keep away from moving parts	Crush hazard	Overhead obstruction	Collision hazard
				
Electrocution hazard	Maintain required clearance	Tip-over hazard	Tip-over hazard	Tip-over hazard
				
Electrocution hazard	Avoid contact	Disconnect battery	Read the operator's manual	Read the service manual
				
Explosion hazard	No smoking. No flame. Stop engine.	Explosion hazard	Burn hazard	Fire extinguisher
				
Fire hazard	No smoking	Explosion hazard	No step	Lanyard anchorage points

Symbol and Hazard Pictorials Definitions

 <p>Platform tie-down instructions</p>	 <p>Lifting & tie down instructions</p>		 <p>Tie-down point</p>	 <p>Lifting point</p>
 <p>Wind speed</p>	 <p>Maximum capacity</p>	 <p>Weight of welder reduces capacity</p>	 <p>Wheel load</p>	 <p>Tire specifications</p>
<p>Recovery procedure if tilt alarm sounds while elevated</p>  <p>Platform uphill: 1 Lower primary 2 Retract/lower secondary 3 Retract primary</p>  <p>Platform downhill: 1 Retract primary 2 Retract / lower secondary 3 Lower primary</p>		 <p>Do not use ether or other high energy starting aids on machines equipped with glow plugs.</p>	 <p>Voltage rating for power to platform</p>	 <p>Pressure rating for air line to platform</p>
 <p>Color Coded Direction Arrows</p>	 <p>Runaway Hazard</p>	 <p>Access by trained and authorized personnel only</p>	 <p>Manual force</p>	

General Safety

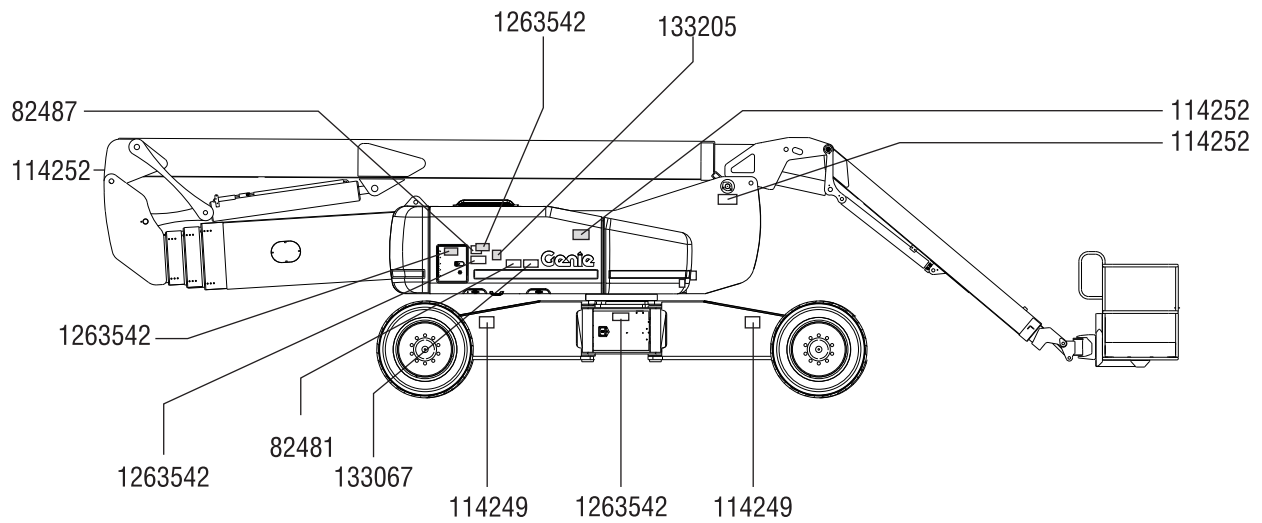

General Safety

219958



160578



133067



114248



160579



82487

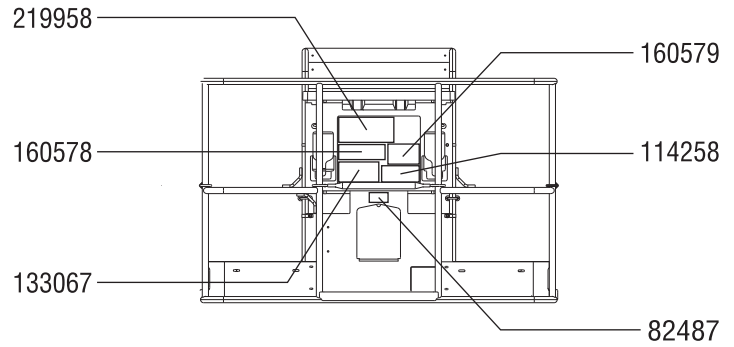

General Safety

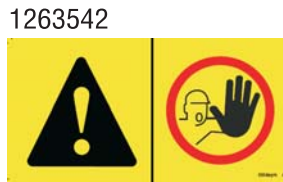
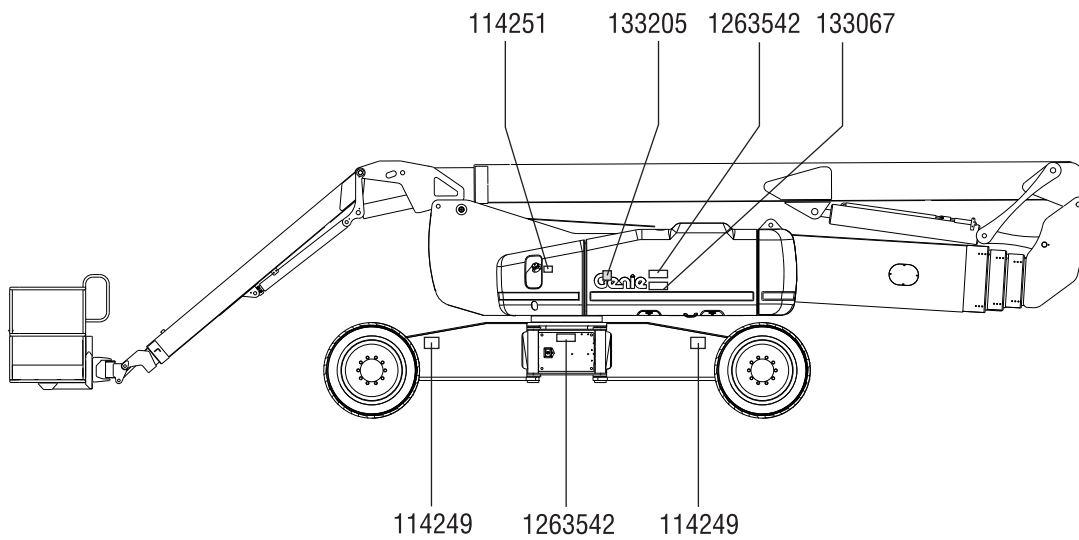

Personal Safety

Personal Fall Protection

Personal fall protection equipment (PFPE) is required when operating this machine.

Occupants must wear a safety belt or harness in accordance with governmental regulations. Attach the lanyard to the anchor provided in the platform.

Operators must comply with employer, job site and governmental rules regarding the use of personal protective equipment.

All PFPE must comply with applicable governmental regulations, and must be inspected and used in accordance with the PFPE manufacturer's instructions.

Work Area Safety

⚠ Electrocuting Hazards

This machine is not electrically insulated and will not provide protection from contact with or proximity to electrical current.

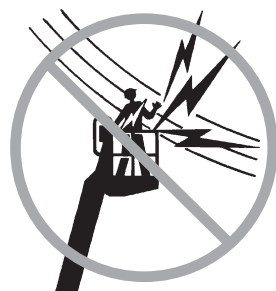

Obey all local and governmental regulations regarding required clearance from electrical power lines. At a minimum, the required clearance contained in the chart below must be followed.

Line Voltage	Required Clearance
0 to 50KV	3.05 m
50 to 200KV	4.60 m
200 to 350KV	6.10 m
350 to 500KV	7.62 m
500 to 750KV	10.67 m
750 to 1000KV	13.72 m

Allow for platform movement, electrical line sway or sag, and beware of strong or gusty winds.



Keep away from the machine if it contacts energized power lines. Personnel on the ground or in the platform must not touch or operate the machine until energized power lines are shut off.

Do not operate the machine during lightning or storms.

Do not use the machine as a ground for welding.

⚠ Tip-over Hazards

Occupants, equipment and materials shall not exceed the maximum platform capacity.

Maximum platform capacity	272 kg
Maximum occupants	2

The weight of options and accessories, such as pipe cradles, panel cradles and welders, will reduce the rated platform capacity and must be subtracted from the platform capacity. See the decals with the options and accessories.

If using accessories, read, understand and obey the decals, instructions and manuals with the accessory.

Work Area Safety



Do not raise or extend the boom unless the machine is on a firm, level surface.



Do not depend on the tilt alarm as a level indicator. The tilt alarm sounds in the platform only when the machine is on a severe slope.

If the tilt alarm sounds while the boom is lowered: Do not extend, rotate or raise the boom above horizontal. Move the machine to a firm, level surface before raising the platform.

If the tilt alarm sounds when the platform is raised, use extreme caution. The machine not level indicator light will come on and the drive function in one or both directions will not operate. Identify the condition of the boom on the slope as shown below. Follow the steps to lower the boom before moving to a firm, level surface. Do not rotate the boom while lowering.

The recovery mode should be used only by trained and authorized personnel.

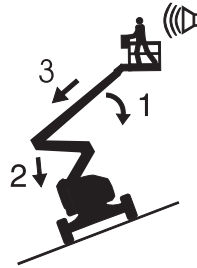

If the tilt alarm sounds with the platform uphill:

- 1 Lower the primary boom.
- 2 Lower the secondary boom.
- 3 Retract the primary boom.

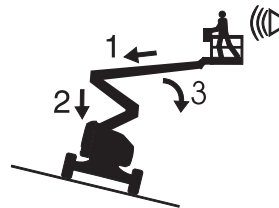

If the tilt alarm sounds with the platform downhill:

- 1 Retract the primary boom.
- 2 Lower the secondary boom.
- 3 Lower the primary boom.

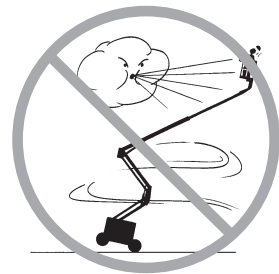

Do not raise the boom when wind speeds may exceed 12.5 m/s. If wind speeds exceed 12.5 m/s when the boom is raised, lower the boom and do not continue to operate the machine.

Do not operate the machine in strong or gusty winds. Do not increase the surface area of the platform or the load. Increasing the area exposed to the wind will decrease machine stability.

Work Area Safety



Use extreme care and slow speeds while driving the machine in the stowed position across uneven terrain, debris, unstable or slippery surfaces and near holes and drop-offs.

Do not drive the machine on or near uneven terrain, unstable surfaces or other hazardous conditions with the boom raised or extended.

Do not use the machine as a crane.

Do not push the machine or other objects with the boom.

Do not contact adjacent structures with the boom.

Do not tie the boom or platform to adjacent structures.

Do not place loads outside the platform perimeter.



Do not push off or pull toward any object outside of the platform.

**Maximum allowable
manual force – CE**
400 N

Do not alter or disable machine components that in any way affect safety and stability.

Do not replace items critical to machine stability with items of different weight or specification.

Do not replace factory-installed tires with tires of different specification or ply rating.

Do not use the platform controls to free a platform that is caught, snagged or otherwise prevented from normal motion by an adjacent structure. All personnel must be removed from the platform before attempting to free the platform using the ground controls.

Do not use air-filled tires. These machines are equipped with foam-filled tires. Wheel weight is critical to stability.

Do not modify or alter an aerial work platform without prior written permission from the manufacturer. Mounting attachments for holding tools or other materials onto the platform, toeboards or guard rail system can increase the weight in the platform and the surface area of the platform or the load.

Work Area Safety



Do not place or attach fixed or overhanging loads to any part of this machine.



Do not place ladders or scaffolds in the platform or against any part of this machine.

Do not transport tools and materials unless they are evenly distributed and can be safely handled by person(s) in the platform.

Do not use the machine on a moving or mobile surface or vehicle.

Be sure the tires are in good condition and the lug nuts tightened.

⚠ Operation on Slopes Hazards

Do not drive the machine on a slope that exceeds the maximum uphill, downhill or side slope rating of the machine. Slope rating applies only to machines in the stowed position.

Maximum slope rating, stowed position

Platform downhill	45% (24°)
Platform uphill	30% (17°)
Side slope	25% (14°)

Note: Slope rating is subject to ground conditions and adequate traction. See Driving on a Slope in the Operating Instructions section.

Work Area Safety

⚠ Fall Hazards

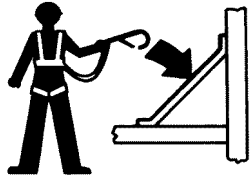

Occupants must wear a safety belt or harness in accordance with governmental regulations. Attach the lanyard to the anchor provided in the platform.



Do not sit, stand or climb on the platform guard rails. Maintain a firm footing on the platform floor at all times.



Do not climb down from the platform when raised.

Keep the platform floor clear of debris.

Lower the platform entry mid-rail or close the entry gate before operating.

Do not enter or exit the platform unless the machine is in the stowed position and the platform is at ground level.

⚠ Collision Hazards



Be aware of limited sight distance and blind spots when driving or operating.

Be aware of the boom position and tailswing when rotating the turntable.

Be aware of machine length when operating. The machine is 12.9 m long.



Check the work area for overhead obstructions or other possible hazards.



Be aware of crushing hazards when grasping the platform guard rail.

Operators must comply with employer, job site and governmental rules regarding use of personal protective equipment.

Work Area Safety

Observe and use the color-coded direction arrows on the platform controls and drive chassis for drive and steer functions.



Do not lower the boom unless the area below is clear of personnel and obstructions.



Limit travel speed according to the condition of the ground surface, congestion, slope, location of personnel, and any other factors which may cause collision.

Do not operate a boom in the path of any crane unless the controls of the crane have been locked out and/or precautions have been taken to prevent any potential collision.

No stunt driving or horseplay while operating a machine.

▲ Bodily Injury Hazard

Always operate the machine in a well-ventilated area to avoid carbon monoxide poisoning.

Do not operate the machine with a hydraulic oil or air leak. An air leak or hydraulic leak can penetrate and/or burn skin.

Improper contact with components under any cover will cause serious injury. Only trained maintenance personnel should access compartments. Access by the operator is only advised when performing a pre-operation inspection. All compartments must remain closed and secured during operation.

▲ Explosion and Fire Hazards

Do not start the engine if you smell or detect liquid petroleum gas (LPG), gasoline, diesel fuel or other explosive substances.

Do not refuel the machine with the engine running.

Refuel the machine and charge the battery only in an open, well-ventilated area away from sparks, flames and lighted tobacco.

Do not operate the machine or charge the battery in hazardous locations or locations where potentially flammable or explosive gases or particles may be present.

Do not spray ether into engines equipped with glow plugs.

Work Area Safety

⚠ Damaged Machine Hazards

Do not use a damaged or malfunctioning machine.

Conduct a thorough pre-operation inspection of the machine and test all functions before each work shift. Immediately tag and remove from service a damaged or malfunctioning machine.

Be sure all maintenance has been performed as specified in this manual and the appropriate Genie service manual.

Be sure all decals are in place and legible.

Be sure the operator's, safety and responsibilities manuals are complete, legible and in the storage container located on the machine.

⚠ Component Damage Hazards

Do not use any battery or charger greater than 12V to jump-start the engine. Apply jumper cables to the starter and controls battery, not the auxiliary power batteries.

Do not use the machine as a ground for welding unless the machine is equipped with the weld line to platform option and it is properly connected.

⚠ Battery Safety

Burn Hazards



Batteries contain acid. Always wear protective clothing and eye wear when working with batteries.

Avoid spilling or contacting battery acid. Neutralize battery acid spills with baking soda and water.

Explosion Hazards



Keep sparks, flames and lighted tobacco away from batteries. Batteries emit explosive gas.

⚠ Electrocutation Hazard

Avoid contact with electrical terminals.

Work Area Safety

▲ Welder Safety

Read, understand and obey all warnings and instructions provided with the welding power unit.

Do not connect weld leads or cables unless the welding power unit is turned off at the platform controls.

Do not operate unless the weld cables are properly connected and the welder is properly grounded.

The weight of the welder will reduce the rated platform capacity and must be factored into the total platform load. The welder power supply weighs 34 kg.

Do not operate the welder unless a fire extinguisher is immediately available for instant use, per OSHA regulation 1926.352(d).

▲ Weld Line to Platform Safety

Read, understand and obey all warnings and instructions provided with the welding power unit.

Do not connect weld leads or cables unless the welding power unit is turned off at the platform controls.

Do not operate unless the weld cables are properly connected.

Connect the positive lead to the twist-lock connector at the turntable and platform.

Clamp the negative lead to the ground post at the turntable and platform.

Lockout After Each Use

- 1 Select a safe parking location—firm level surface, clear of obstruction and traffic.
- 2 Retract and lower the boom to the stowed position.
- 3 Rotate the turntable so that the boom is between the non-steer wheels.
- 4 Turn the key switch to the off position and remove the key to secure from unauthorized use.

Legend

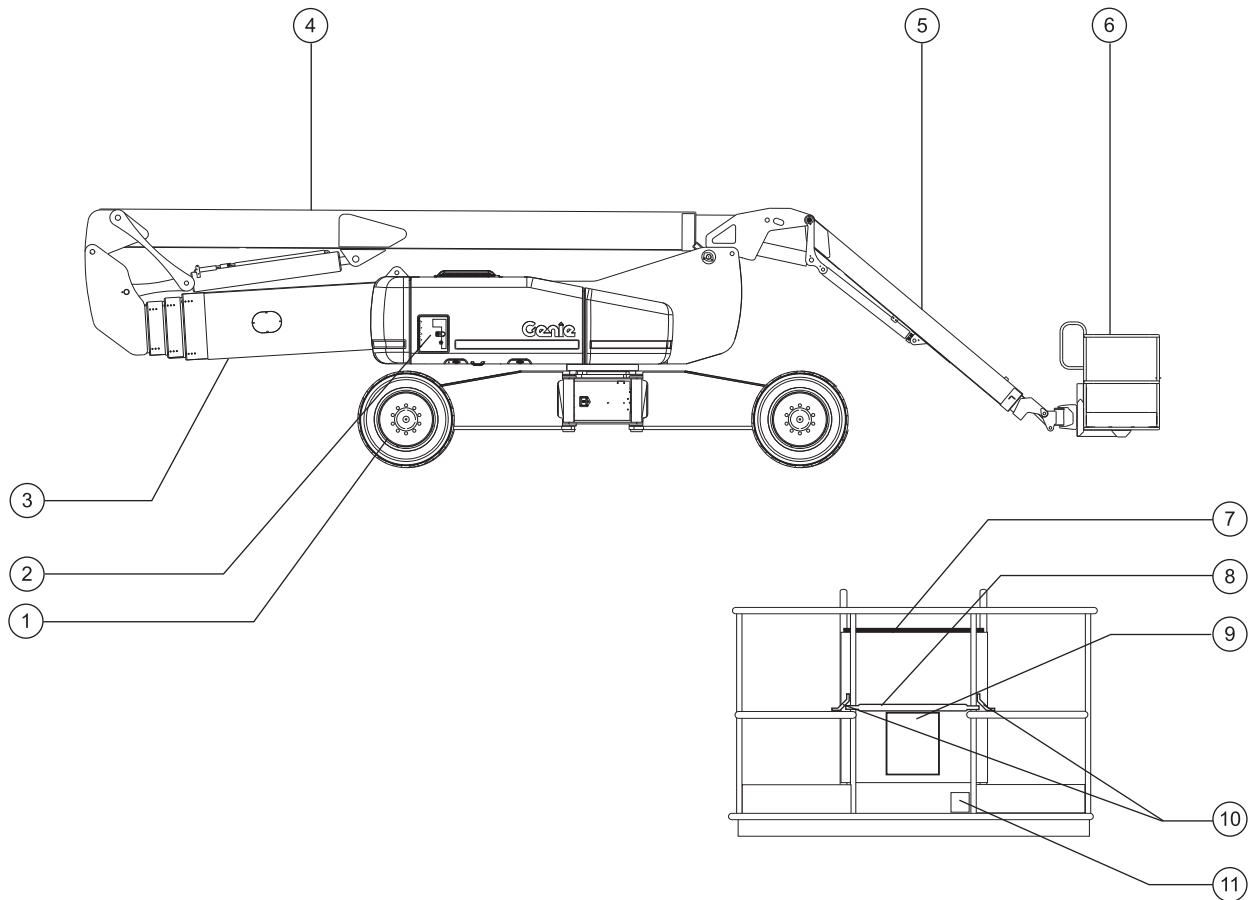

- 1 Square-end tire
- 2 Ground controls
- 3 Secondary boom
- 4 Primary boom
- 5 Jib boom
- 6 Platform

- 7 Platform controls
- 8 Sliding mid-rail
- 9 Manual storage container
- 10 Lanyard anchorage points
- 11 Foot switch

Controls

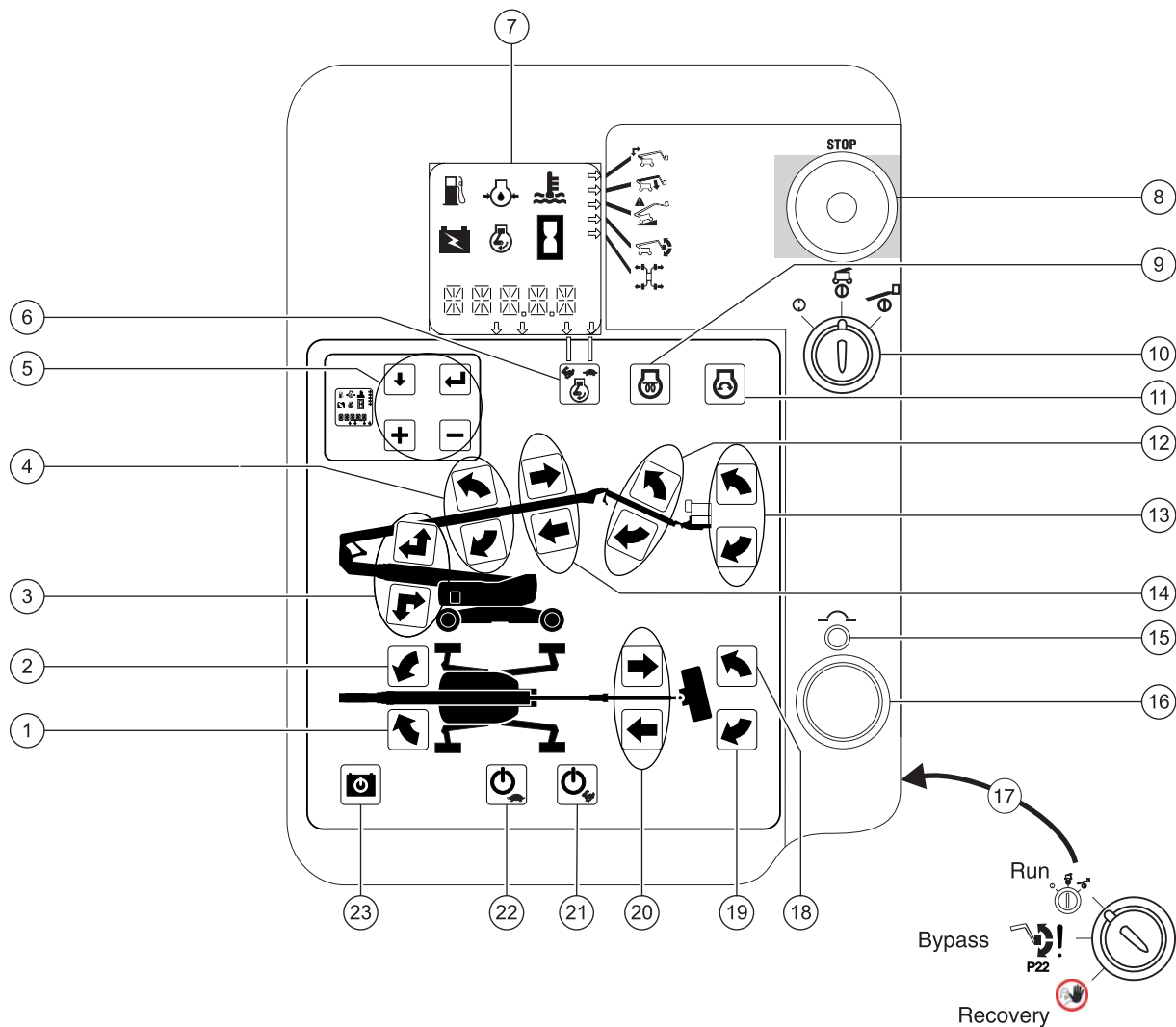

Ground Control Panel

- | | | |
|---|---|--------------------------------------|
| 1 Turntable rotate right button | 9 Glow plug button | 16 Alarm |
| 2 Turntable rotate left button | 10 Key switch for off/ground/platform selection | 17 Bypass/recovery key switch |
| 3 Secondary boom up/extend and down/retract buttons | 11 Engine start button | 18 Platform rotate right button |
| 4 Primary boom up/down buttons | 12 Jib boom up/down buttons | 19 Platform rotate left button |
| 5 LCD screen control buttons | 13 Platform level up/down buttons | 20 Jib boom extend/retract buttons |
| 6 Engine speed select button | 14 Primary boom extend/retract buttons | 21 High speed function enable button |
| 7 LCD readout screen | 15 20A circuit breaker for system circuit | 22 Low speed function enable button |
| 8 Red Emergency Stop button | | 23 Emergency power button |



Controls

Ground Control Panel

1 Turntable rotate right button

Press the turntable rotate right button and the turntable will rotate right.

2 Turntable rotate left button

Press the turntable rotate left button and the turntable will rotate left.

3 Secondary boom up/extend and down/retract buttons

Push the secondary boom up/extend button and the secondary boom will raise and then extend. Push the secondary boom down/retract button and the secondary boom will retract and then lower.

4 Primary boom up/down buttons

Press the primary boom up button and the boom will raise. Press the primary boom down button and the boom will lower.

5 LCD screen control buttons

6 Engine speed select button

Press the engine speed select button to select the engine speed. When the arrow above the rabbit is lit, the engine is in high idle speed. When the arrow above the turtle is lit, the engine is in low idle speed.

7 LCD readout screen



- a low fuel indicator
- b engine oil pressure indicator
- c water temperature indicator
- d emergency power indicator
- e high engine rpm indicator
- f hour meter

8 Red Emergency Stop button

Push in the red Emergency Stop button to the off position to stop all functions and turn the engine off. Pull out the red Emergency Stop button to the on position to operate the machine.

9 Glow plug button (if equipped with manual glow plugs)

Push the glow plug button and hold for 3 to 5 seconds.

10 Key switch for off/ground/platform selection

Turn the key switch to the off position and the machine will be off. Turn the key switch to the ground position and the ground controls will operate. Turn the key switch to the platform position and the platform controls will operate.

11 Engine start button

Press the engine start button to start the engine.

Controls

12 Jib boom up/down buttons

Press the jib boom up button and the jib boom will raise. Press the jib boom down button and the jib boom will lower.

13 Platform level up/down buttons

Press the platform level up button and the level of the platform will raise. Press the platform level down button and the level of the platform will lower.

14 Primary boom extend/retract buttons

Press the primary boom extend button and the primary boom will extend. Press the primary boom retract button and the primary boom will retract.

15 20A circuit breaker for system circuit

16 Alarm

17 Bypass/recovery key switch

Bypass key position to be used only to level the platform if the ground control display shows platform out of level (P22) and platform level controls do not work. Refer to the operating instructions.

Recovery key position should be used only by trained and authorized personnel.

18 Platform rotate right button

Press the platform rotate right button and the platform will rotate right.

19 Platform rotate left button

Press the platform rotate left button and the platform will rotate left.

20 Jib boom extend/retract buttons

Press the jib boom extend button and the jib boom will extend. Press the jib boom retract button and the jib boom will retract.

21 High speed function enable button

Press the high speed function enable button to enable the functions on the ground control panel to operate at high speed.

22 Low speed function enable button

Press the low speed function enable button to enable the functions on the ground control panel to operate at low speed.

23 Emergency power button

Use emergency power if the primary power source (engine) fails. Simultaneously hold the emergency power button and activate the desired function.

Controls

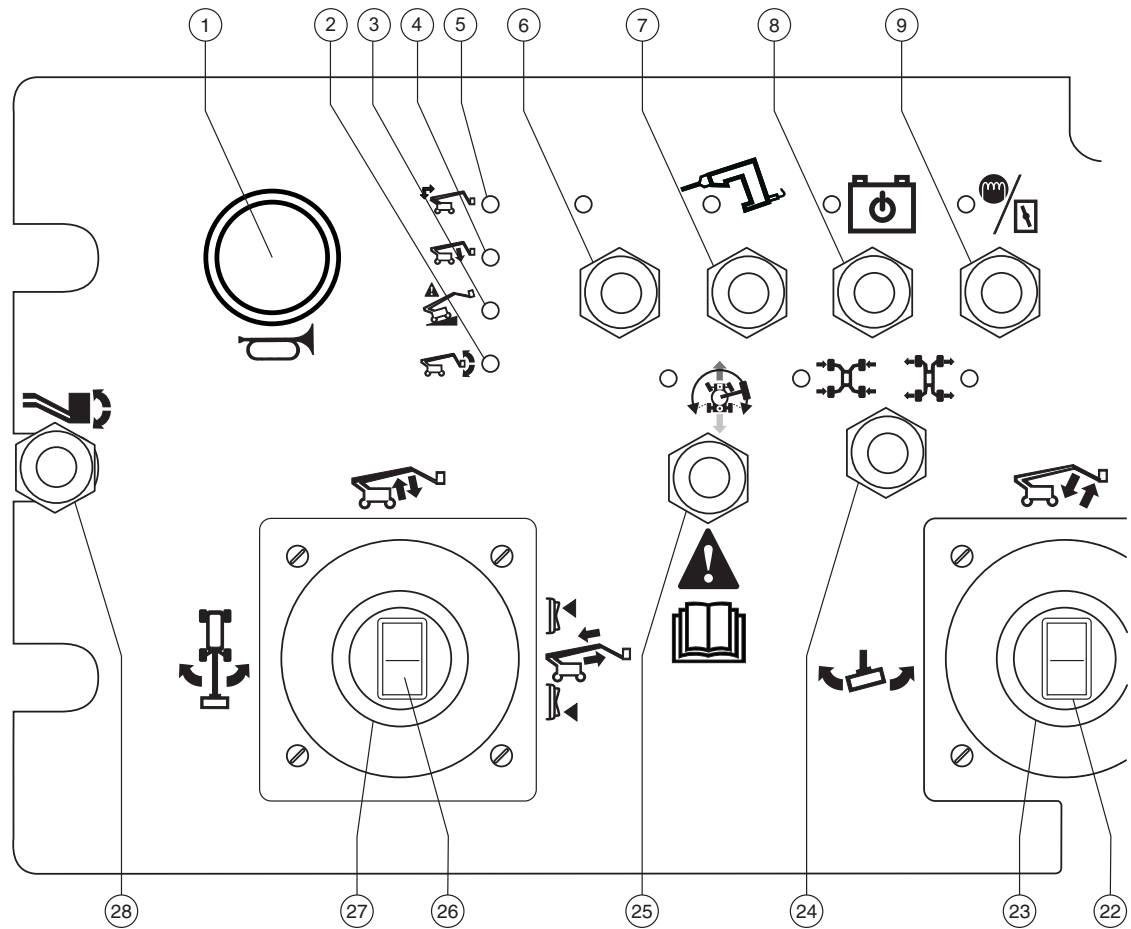

Platform Control Panel

- | | | |
|--|---|---|
| <ul style="list-style-type: none"> 1 Horn button 2 Platform not level indicator light 3 Machine on incline indicator light 4 Lower primary boom indicator light 5 Lower / retract secondary boom indicator light 6 Used for optional equipment | <ul style="list-style-type: none"> 7 Generator switch with indicator light (if equipped) 8 Emergency power switch 9 Diesel models: Glow plug switch with indicator light
Gasoline/LPG models: Choke switch with indicator light 10 Engine start switch with indicator light | <ul style="list-style-type: none"> 11 Engine idle select switch with indicator light: <ul style="list-style-type: none"> • Rabbit: high idle • Turtle: low idle 12 Platform overload indicator light 13 Power indicator light 14 Check engine indicator light 15 Low fuel indicator light 16 Fault indicator light 17 Red Emergency Stop button |
|--|---|---|

Controls

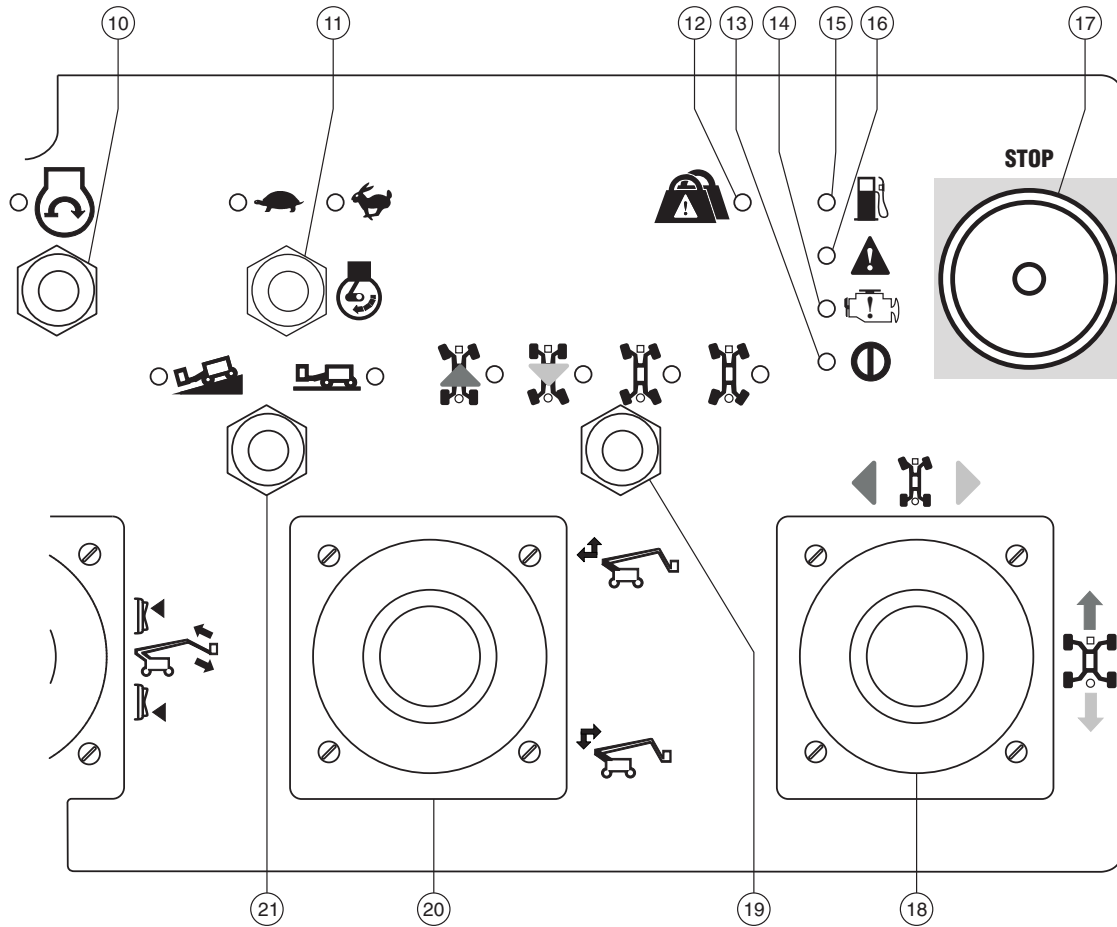

- 18 Dual axis proportional control handle for drive and steer functions
OR Proportional control handle for drive function and thumb rocker for steer function
- 19 Steer mode select switch with indicator lights
- 20 Single axis proportional control handle for secondary boom up/extend and down/retract function

- 21 Drive select switch with indicator lights
Machine on incline symbol: Low range operation for inclines
Machine on level surface symbol: High range operation for maximum drive speed
- 22 Thumb rocker for jib boom extend/retract function
- 23 Dual axis proportional control handle for jib boom up/down and platform rotate left/right functions

- 24 Axle extend/retract switch with indicator lights
- 25 Drive enable switch with indicator light
- 26 Thumb rocker switch for primary boom extend/retract function
- 27 Dual axis proportional control handle for primary boom up/down and turntable rotate left/right functions
- 28 Platform level switch



Controls

Platform Control Panel

- 1 Horn button
Press this button and the horn will sound. Release the button and the horn will stop.
- 2 Platform not level indicator light
Level the platform until the light is off. The platform level toggle switch will only work in the direction that will level the platform.
- 3 Machine not level indicator light
Light is on when the platform is raised and the machine is on a severe slope. The drive function in one or both directions will not operate. The turntable rotate may also be disabled.
- 4 Lower primary boom indicator light
Lower the primary boom until the light is off.
- 5 Lower / retract secondary boom indicator light
Lower/retract the secondary boom until the light is off.
- 6 Used for optional equipment
- 7 Generator switch with indicator light (if equipped)
Move the generator switch to turn the generator on. Move the switch again to turn the generator off.
- 8 Emergency power switch with indicator light
Use emergency power if the primary power source (engine) fails. Simultaneously move the emergency power switch and activate the desired function. The indicator light will be on when emergency power is being used.
- 9 Gasoline/LPG models: Choke switch with indicator light
Move this switch to activate the choke.
OR
Diesel models: automatic glow plug light or glow plug switch
Glow plug switch with indicator light
Move this switch and hold 3 to 5 seconds to activate the glow plugs.
Automatic glow plug indicator light
Amber light indicates glow plugs are on.
- 10 Engine start switch with indicator light
Move the engine start switch and the engine will start. The engine start indicator light will be on when the switch is Moved.
- 11 Engine idle select switch with indicator light:
Move this switch to select engine idle setting. Rabbit symbol light on indicates high idle is selected. Turtle symbol light on indicates low idle is selected.

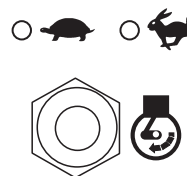

Controls

- 12 Platform overload indicator light
Light flashing indicates the platform is overloaded. The engine will stop and no functions will operate. Remove weight until the light goes off and then restart the engine.
- 13 Power indicator light
Light on indicates the machine is on.
- 14 Check engine indicator light
Light on indicates an engine fault.
- 15 Low fuel indicator light
Light on indicates the machine is low on fuel.
- 16 Fault indicator light
Light on indicates a system fault.
- 17 Red Emergency Stop button
Push in the red Emergency Stop button to the off position to stop all functions and turn the engine off. Pull out the red Emergency Stop button to the on position to operate the machine.
- 18 Dual axis proportional control handle for drive and steer functions
OR Proportional control handle for drive function and thumb rocker for steer function.
Move the control handle in the direction indicated by the blue arrow on the control panel and the machine will drive forward. Move the control handle in the direction indicated by the yellow arrow and the machine will drive backwards. Move the control handle in the direction indicated by the blue triangle and the machine will steer to the left. Move the control handle in the direction indicated by the yellow triangle and the machine will steer to the right.
OR
Move the control handle in the direction indicated by the blue arrow on the control panel and the machine will drive forward. Move the control handle in the direction indicated by the yellow arrow and the machine will drive backwards. Press the left side of the thumb rocker and the machine will steer to the left. Press the right side of the thumb rocker and the machine will steer to the right.

Controls

19 Steer mode select switch with indicator lights

Move the steer mode select switch to choose steer mode. The indicator light next to the current steer mode will be on.

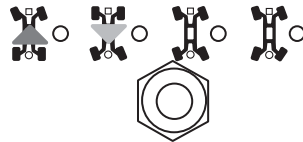

20 Single axis proportional control handle for secondary boom up/extend and down/retract function

Move the control handle up and the secondary boom will raise and then extend. Move the control handle down and the secondary boom will retract and then lower.



21 Drive select switch with indicator lights

Move the drive select switch to choose drive setting. The indicator light next to the current setting will be on.

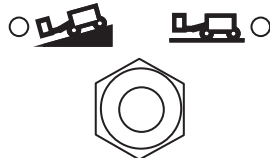

22 Thumb rocker for jib boom extend/retract function

Push the top of the rocker switch and the jib boom will retract. Push the bottom of the rocker switch and the jib boom will extend.



23 Dual axis proportional control handle for jib boom up/down and platform rotate left/right functions

Move the control handle up and the jib boom will raise. Move the control handle down and the jib boom will lower. Move the control handle to the left and the platform will rotate to the left. Move the control handle to the right and the platform will rotate to the right.



Controls

24 Axle extend/retract switch with indicator lights

Move the axle select switch to choose an axle setting. The indicator light will flash while the axles are extending and stay on when the axles are fully extended. The indicator light will flash while the axles are retracting and stay on when the axles are fully retracted.

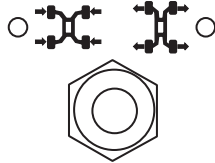

25 Drive enable switch with indicator light

Light on indicates that the primary boom has moved past either circle-end wheel and the drive function is turned off. To drive, move the drive enable switch and slowly move the drive control handle off center.

26 Thumb rocker switch for primary boom extend/retract function

Push the top of the rocker switch and primary boom will retract. Push the bottom of the rocker switch and the primary boom will extend.



27 Dual axis proportional control handle for primary boom up/down and turntable rotate left/right functions

Move the control handle up and the primary boom will raise. Move the control handle down and the primary boom will lower. Move the control handle to the left and the turntable will rotate to the left. Move the control handle to the right and the turntable will rotate to the right.

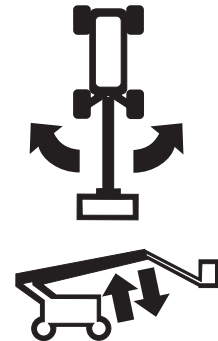

28 Platform level switch

Move the platform level switch up and the level of the platform will raise. Move the platform level switch down and the level of the platform will lower.



Inspections



Do Not Operate Unless:

- You learn and practice the principles of safe machine operation contained in this operator's manual.
 - 1 Avoid hazardous situations.
 - 2 Always perform a pre-operation inspection.**
- Know and understand the pre-operation inspection before going on to the next section.**
 - 3 Always perform function tests prior to use.
 - 4 Inspect the workplace.
 - 5 Only use the machine as it was intended.

Pre-operation Inspection Fundamentals

It is the responsibility of the operator to perform a pre-operation inspection and routine maintenance.

The pre-operation inspection is a visual inspection performed by the operator prior to each work shift. The inspection is designed to discover if anything is apparently wrong with a machine before the operator performs the function tests.

The pre-operation inspection also serves to determine if routine maintenance procedures are required. Only routine maintenance items specified in this manual may be performed by the operator.

Refer to the list on the next page and check each of the items.

If damage or any unauthorized variation from factory delivered condition is discovered, the machine must be tagged and removed from service.

Repairs to the machine may only be made by a qualified service technician, according to the manufacturer's specifications. After repairs are completed, the operator must perform a pre-operation inspection again before going on to the function tests.

Scheduled maintenance inspections shall be performed by qualified service technicians, according to the manufacturer's specifications and the requirements listed in the responsibilities manual.

Inspections

Pre-operation Inspection

- Be sure that the operator's, safety and responsibilities manuals are complete, legible and in the storage container located in the platform.
- Be sure that all decals are legible and in place. See Inspections section.
- Check for hydraulic oil leaks and proper oil level. Add oil if needed. See Maintenance section.
- Check for battery fluid leaks and proper fluid level. Add distilled water if needed. See Maintenance section.
- Check for engine oil leaks and proper oil level. Add oil if needed. See Maintenance section.
- Check for engine coolant leaks and proper level of coolant. Add coolant if needed. See Maintenance section.

Check the following components or areas for damage, improperly installed or missing parts and unauthorized modifications:

- Electrical components, wiring and electrical cables
- Hydraulic hoses, fittings, cylinders and manifolds
- Fuel and hydraulic tanks
- Drive and turntable motors and drive hubs
- Wear pads
- Tires and wheels
- Engine and related components
- Limit switches and horn
- Rotation sensors

- Steer and axle sensors
- Alarms and beacons (if equipped)
- Nuts, bolts and other fasteners
- Platform entry mid-rail or gate
- Lanyard anchorage points

Check entire machine for:

- Cracks in welds or structural components
- Dents or damage to machine
- Excessive rust, corrosion or oxidation
- Be sure that all structural and other critical components are present and all associated fasteners and pins are in place and properly tightened.
- After you complete your inspection, be sure that all compartment covers are in place and latched.

Inspections



Do Not Operate Unless:

- You learn and practice the principles of safe machine operation contained in this operator's manual.
 - 1 Avoid hazardous situations.
 - 2 Always perform a pre-operation inspection.
 - 3 Always perform function tests prior to use.**

Know and understand the function tests before going on to the next section.

- 4 Inspect the workplace.
- 5 Only use the machine as it was intended.

Function Test Fundamentals

The function tests are designed to discover any malfunctions before the machine is put into service. The operator must follow the step-by-step instructions to test all machine functions.

A malfunctioning machine must never be used. If malfunctions are discovered, the machine must be tagged and removed from service. Repairs to the machine may only be made by a qualified service technician, according to the manufacturer's specifications.

After repairs are completed, the operator must perform a pre-operation inspection and function tests again before putting the machine into service.

Inspections

At the Ground Controls

- 1 Select a test area that is firm, level and free of obstruction.
- 2 Turn the key switch to ground control.
- 3 Pull out the red Emergency Stop button to the on position.
- ⊙ Result: The beacons (if equipped) should flash.
- 4 Start the engine. See Operating Instructions section.

Test Emergency Stop

- 5 Push in the red Emergency Stop button to the off position.
- ⊙ Result: The engine should shut off and no functions should operate.
- 6 Pull out the red Emergency Stop button to the on position and restart the engine.

Test the Extendable Axles

Note: Start this test with the axles retracted.

- 7 At the ground controls, push and hold a function enable/speed select button and push the primary boom up button.
 - ⊙ Result: The primary boom should not raise. On the LCD screen, the arrow next to the extend axle symbol will flash. The boom should not raise unless the axles are extended.
- 8 Push and hold a function enable/speed select button and press the secondary boom raise/extend button.
 - ⊙ Result: The secondary boom should not raise. On the LCD screen, the arrow next to the extend axle symbol will flash. The secondary boom should not raise unless the axles are extended.
- 9 Push and hold a function enable/speed select button and press the primary boom extend button.
 - ⊙ Result: The primary boom should not extend. On the LCD screen, the arrow next to the extend axle symbol will flash. The primary boom should not extend unless the axles are extended.

Inspections

- 10 Push and hold a function enable/speed select button and push the turntable rotate left button.
 - ⊙ Result: The turntable should rotate 15° and then stop. The turntable should not rotate more than 15° unless the axles are extended.
- 11 Push and hold a function enable/speed select button and push the turntable rotate right button.
 - ⊙ Result: The turntable should return to center, rotate 15° to the right and then stop. The turntable should not rotate more than 15° unless the axles are extended.
- 12 Turn the key switch to platform control. At the platform controls, move the drive control handle in the forward direction and move the extend axle toggle switch.
 - ⊙ Result: The machine should drive and the axles should extend. The indicator light will flash while the axles are moving and stay on when the axles are fully extended.
- 13 Return to the ground controls. Turn the key switch to ground control.
- 14 Push and hold a function enable/speed select button and push the primary boom up button and then the primary boom down button.
 - ⊙ Result: The primary boom should raise and lower normally.
- 15 Push and hold a function enable/speed select button and push the secondary boom raise/extend button and then the secondary boom lower/retract button.
 - ⊙ Result: The secondary boom should raise and extend and retract and lower normally.
- 16 Push and hold a function enable/speed select button and push the primary boom extend button and then the primary boom retract button.
 - ⊙ Result: The primary boom should extend and retract normally.
- 17 Push and hold a function enable/speed select button and push the turntable rotate left button and then the turntable rotate right button.
 - ⊙ Result: The turntable should rotate normally.

Inspections

Test Machine Functions

- 18 Do not press and hold a function enable/speed select button. Attempt to activate each boom and platform function button.
- ⊙ Result: No boom and platform functions should operate.
- 19 Press and hold a function enable/speed select button and activate each boom and platform function button.
- ⊙ Result: All boom and platform functions should operate through a full cycle. The descent alarm should sound while the boom is lowering.

Test Emergency Controls

- 20 Push in the red Emergency Stop button to the off position to shut off the engine.
- 21 Pull out the red Emergency Stop button to the on position.
- 22 Simultaneously push and hold the emergency power button and push each boom function button.



Note: To conserve battery power, test each function through a partial cycle.

- ⊙ Result: All boom functions should operate.
- 23 Start the engine.







Test the Tilt Sensor

- 24 Press one of the LCD screen control buttons until TURNTABLE LEVEL SENSOR X-DIRECTION appears.
- ↓

↶
- ⊙ Result: The LCD screen should display the angle in degrees.
- 25 Press the LCD screen control buttons until TURNTABLE LEVEL SENSOR Y-DIRECTION appears.
- ⊙ Result: The LCD screen should display the angle in degrees.
- 26 Press the LCD screen control buttons until PLATFORM LEVEL SENSOR DEGREES appears.
- ⊙ Result: The LCD screen should display the angle in degrees.

Inspections

Test the Operating Envelope

- 27 Press the LCD screen control buttons shown until PRI BOOM ANGLE TO GRAVITY is displayed.
-  
- 28 Raise the primary boom and observe the LCD screen.
- ⊙ Result: The primary boom should raise and the LCD screen should display the primary boom angle in degrees.
- 29 Lower the primary boom.
- 30 Simultaneously press the 2 LCD screen control buttons shown to activate status mode.
-  
- 31 Press the LCD screen control buttons shown until SEC BOOM ANGLE is displayed.
-  
- 32 Press and hold the secondary boom up/extend button.
- ⊙ Result: The secondary boom should raise and the LCD screen should display the secondary boom angle in degrees.
- The secondary boom should raise and then extend. The secondary boom should not extend until it is fully raised.
- 33 Press and hold the secondary boom down/retract button.
- ⊙ Result: The secondary boom should fully retract and then lower. The secondary boom should not lower unless it is fully retracted.

Inspections

At the Platform Controls

Test Emergency Stop

- 34 Turn the key switch to platform control.
- 35 Push in the platform red Emergency Stop button to the off position.
 - ⊙ Result: The engine should shut off and no functions should operate.
- 36 Pull out the red Emergency Stop button and restart the engine.

Test the Horn

- 37 Press the horn button.
 - ⊙ Result: The horn should sound.

Test the Tilt Sensor Alarm

- 38 Move a toggle switch, such as the engine idle select switch.
 - ⊙ Result: The alarm should sound at the platform controls.

Test the Foot Switch

- 39 Push in the platform red Emergency Stop button to the off position.
- 40 Pull out the red Emergency Stop button to the on position and do not start the engine.
- 41 Press down the foot switch and attempt to start the engine by moving the start toggle switch to either side.
 - ⊙ Result: The engine should not start.
- 42 Do not press down the foot switch and restart the engine.
 - ⊙ Result: The engine should start.
- 43 Do not press down the foot switch and test each machine function.
 - ⊙ Result: No functions should operate.

Test Machine Functions

- 44 Press down the foot switch.
- 45 Activate each function control handle, toggle switch or thumb rocker switch.
 - ⊙ Result: All functions should operate through a full cycle.

Inspections

Test the Steering

- 46 Move the steer mode select switch and choose square-end (blue arrow) steer.

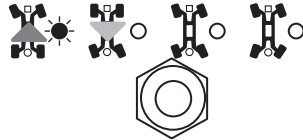

- 47 Press down the foot switch.

- 48 Slowly move the drive control handle in the direction indicated by the blue triangle on the control panel OR press the thumb rocker switch in the direction indicated by the blue triangle.

- ⊙ Result: The square-end wheels should turn in the direction that the blue triangles point on the drive chassis.

- 49 Slowly move the control handle in the direction indicated by the yellow triangle on the control panel OR press the thumb rocker switch in the direction indicated by the yellow triangle.

- ⊙ Result: The square-end wheels should turn in the direction that the yellow triangles point on the drive chassis.

- 50 Move the steer mode select switch and choose circle-end (yellow arrow) steer.

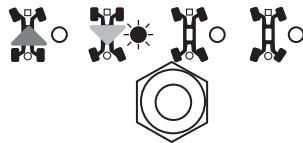

- 51 Press down the foot switch.

- 52 Slowly move the control handle in the direction indicated by the yellow triangle on the control panel OR press the thumb rocker switch in the direction indicated by the yellow triangle.

- ⊙ Result: The circle-end wheels should turn in the direction that the blue triangles point on the drive chassis.

- 53 Slowly move the drive control handle in the direction indicated by the blue triangle on the control panel OR press the thumb rocker switch in the direction indicated by the blue triangle.

- ⊙ Result: The circle-end wheels should turn in the direction that the yellow triangles point on the drive chassis.

- 54 Move the steer mode select switch and choose crab steer.

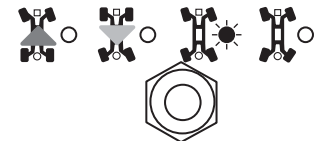

- 55 Press down the foot switch.

- 56 Slowly move the drive control handle in the direction indicated by the blue triangle on the control panel OR press the thumb rocker switch in the direction indicated by the blue triangle.

- ⊙ Result: All wheels should turn in the direction that the blue triangles point on the drive chassis.

Inspections

57 Slowly move the control handle in the direction indicated by the yellow triangle on the control panel OR press the thumb rocker switch in the direction indicated by the yellow triangle.

- ⊙ Result: All wheels should turn in the direction that the yellow triangles point on the drive chassis.

58 Move the steer mode select switch and choose coordinated steer.

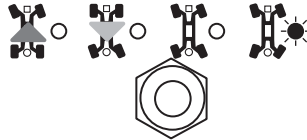

59 Press down the foot switch.

60 Slowly move the drive control handle in the direction indicated by the blue triangle on the control panel OR press the thumb rocker switch in the direction indicated by the blue triangle.

- ⊙ Result: The square-end wheels should turn in the direction that the blue triangles point on the drive chassis. The circle-end wheels should turn in the direction that the yellow triangles point on the drive chassis.

61 Slowly move the control handle in the direction indicated by the yellow triangle on the control panel OR press the thumb rocker switch in the direction indicated by the yellow triangle.

- ⊙ Result: The square-end wheels should turn in the direction that the yellow triangles point on the drive chassis. The circle-end wheels should turn in the direction that the blue triangles point on the drive chassis.

Test Drive and Braking

62 Press down the foot switch.

63 Slowly move the drive control handle in the direction indicated by the blue arrow on the control panel until the machine begins to move, then return the handle to the center position.

- ⊙ Result: The machine should move in the direction that the blue arrow points on the drive chassis, then come to an abrupt stop.

64 Slowly move the control handle in the direction indicated by the yellow arrow on the control panel until the machine begins to move, then return the handle to the center position.

- ⊙ Result: The machine should move in the direction that the yellow arrow points on the drive chassis, then come to an abrupt stop.

Note: The brakes must be able to hold the machine on any slope it is able to climb.

Inspections

Test the Drive Enable System

- 65 Press down the foot switch and lower the boom to the stowed position.
- 66 Rotate the turntable until the primary boom moves past one of the circle-end tires.

- ⊙ Result: The drive enable indicator light should come on and remain on while the boom is anywhere in the range shown.

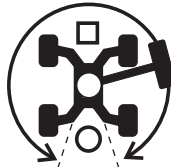

- 67 Move the drive control handle off center.
- ⊙ Result: The drive function should not operate.
- 68 Move the drive enable toggle switch and slowly move the drive control handle off center.
- ⊙ Result: The drive function should operate.

Note: When the drive enable system is in use, the machine may drive in the opposite direction that the drive and steer control handle is moved.

Use the color-coded direction arrows on the platform controls and the drive chassis to identify the direction of travel.

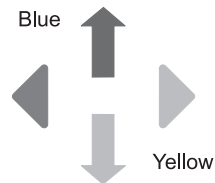

If the drive control handle is not moved within two seconds of moving the drive enable toggle switch, the drive function will not operate.

Test Limited Drive Speed

- 69 Press down the foot switch.
- 70 Raise the primary boom to 10° above horizontal.
- 71 Slowly move the drive control handle to the full drive position.
- ⊙ Result: The maximum achievable drive speed with the primary boom raised should not exceed 30 cm/s.

Note: The machine will travel 12 m in 40 seconds.

- 72 Lower the primary boom to the stowed position.
- 73 Extend the primary boom 1.2 m.
- 74 Slowly move the drive control handle to the full drive position.
- ⊙ Result: The maximum achievable drive speed with the primary boom extended should not exceed 30 cm/s.

Note: The machine will travel 12 m in 40 seconds.

- 75 Retract the primary boom to the stowed position.
- 76 Raise the secondary boom to 5° above horizontal.

Inspections

77 Slowly move the drive control handle to the full drive position.

- ⊙ Result: The maximum achievable drive speed with the secondary boom raised should not exceed 30 cm/s.

Note: The machine will travel 12 m in 40 seconds.

78 Lower the secondary boom to the stowed position.

79 Extend the jib boom 30 cm.

80 Slowly move the drive control handle to the full drive position.

- ⊙ Result: The maximum achievable drive speed with the jib boom extended should not exceed 30 cm/s.

If the drive speed with the primary or secondary boom raised or extended or the jib boom extended exceeds 30 cm/s, immediately tag and remove the machine from service.

81 Extend the primary boom 1.2 m.

82 Slowly move the drive control handle to the full drive position.

- ⊙ Result: The maximum achievable drive speed with the jib boom extended and the primary boom extended should not exceed 15 cm/s.

If the drive speed with the jib boom extended and the primary boom extended exceeds 15 cm/s, immediately tag and remove the machine from service.

83 Retract the primary boom and the jib boom.

Test Drive Tilt Cutout

84 Press down the foot switch.

85 With the boom fully stowed, drive the machine onto a slope where the chassis angle is greater than 4.5° along the Y-Axis (front to back).

- ⊙ Result: The machine should continue to drive.

86 Return to level ground and raise the primary boom to approximately 10° above horizontal.

87 Drive the machine onto a slope where the chassis angle is greater than 4.5° along the Y-Axis (front to back).

- ⊙ Result: The machine should stop once the machine reaches 4.5° of chassis tilt.

88 Lower the primary boom to the stowed position or drive in the opposite direction.

- ⊙ Result: The machine should drive.

89 Return to level ground and extend the primary boom approximately 1.2 m.

90 Drive the machine onto a slope where the chassis angle is greater than 4.5° along the Y-Axis (front to back).

- ⊙ Result: The machine should stop once the machine reaches 4.5° of chassis tilt.

91 Retract the primary boom to the stowed position or drive in the opposite direction.

- ⊙ Result: The machine should drive.

Inspections

- 92 Return to level ground and stow the boom.
- 93 With the boom fully stowed, drive the machine onto a slope where the chassis angle is greater than 4.5° along the Y-Axis (front to back).
- ⊙ Result: The machine should continue to drive.
- 94 Return to level ground and raise the secondary boom to approximately 5° above horizontal.
- 95 Drive the machine onto a slope where the chassis angle is greater than 4.5° along the Y-Axis (front to back).
- ⊙ Result: The machine should stop once the machine reaches 4.5° of chassis tilt.
- 96 Lower the secondary boom to the stowed position or drive in the opposite direction.
- ⊙ Result: The machine should drive.
- 97 Return to level ground and extend the jib boom approximately 30 cm.
- 98 Drive the machine onto a slope where the chassis angle is greater than 4.5° along the Y-Axis (front to back).
- ⊙ Result: The machine should stop once the machine reaches 4.5° of chassis tilt.
- 99 Retract the jib boom to the stowed position or drive in the opposite direction.
- ⊙ Result: The machine should drive.
- 100 Return to level ground and stow the jib boom.
- 101 With the boom fully stowed, drive the machine onto a slope where the chassis angle is greater than 4.5° along the X-Axis (side to side).
- ⊙ Result: The machine should continue to drive.
- 102 Return to level ground and raise the primary boom to approximately 10° above horizontal.
- 103 Drive the machine onto a slope where the chassis angle is greater than 4.5° along the X-Axis (side to side).
- ⊙ Result: The machine should stop once the machine reaches 4.5° of chassis tilt.
- 104 Lower the primary boom to the stowed position or drive in the opposite direction.
- ⊙ Result: The machine should drive.
- 105 Return to level ground and extend the primary boom approximately 1.2 m.
- 106 Drive the machine onto a slope where the chassis angle is greater than 4.5° along the X-Axis (side to side).
- ⊙ Result: The machine should stop once the machine reaches 4.5° of chassis tilt.
- 107 Retract the primary boom to the stowed position or drive in the opposite direction.
- ⊙ Result: The machine should drive.
- 108 Return to level ground and stow the boom.

Inspections

109 With the boom fully stowed, drive the machine onto a slope where the chassis angle is greater than 4.5° along the X-Axis (side to side).

- ⊙ Result: The machine should continue to drive.

110 Return to level ground and raise the secondary boom to approximately 5° above horizontal.

111 Drive the machine onto a slope where the chassis angle is greater than 4.5° along the X-Axis (side to side).

- ⊙ Result: The machine should stop once the machine reaches 4.5° of chassis tilt.

112 Lower the secondary boom to the stowed position or drive in the opposite direction.

- ⊙ Result: The machine should drive.

113 Return to level ground and extend the jib boom approximately 30 cm.

114 Drive the machine onto a slope where the chassis angle is greater than 4.5° along the X-Axis (side to side).

- ⊙ Result: The machine should stop once the machine reaches 4.5° of chassis tilt.

115 Retract the jib boom to the stowed position or drive in the opposite direction.

- ⊙ Result: The machine should drive.

116 Return to level ground and stow the jib boom.

Test Emergency Controls

117 Push in the red Emergency Stop button to the off position to shut off the engine.

118 Pull out the red Emergency Stop button to the on position.

119 Press down the foot switch.

120 Simultaneously move and hold the emergency power switch and activate each function control handle, toggle switch or thumb rocker switch.

Note: To conserve battery power, test each function through a partial cycle.

- ⊙ Result: All boom and steer functions should operate.

Inspections

Test Aircraft Protection Package (if equipped)

Note: Two people may be required to perform this test.

121 Move the yellow bumper at the bottom of the platform 10 cm in any direction.

122 Activate each function control handle, toggle switch or thumb rocker switch.

⊙ Result: No boom and steer functions should operate.

123 Move and hold the function override switch.

124 Activate each function control handle, toggle switch or thumb rocker switch.

⊙ Result: All boom and steer functions should operate.

Test the Lift/Drive Select Function

125 Press down the foot switch.

126 Move the drive control handle off center and activate a boom function toggle switch.

⊙ Result: No boom functions should operate. The machine will move in the direction indicated on the control panel.

Inspections



Do Not Operate Unless:

- ☑ You learn and practice the principles of safe machine operation contained in this operator's manual.
 - 1 Avoid hazardous situations.
 - 2 Always perform a pre-operation inspection.
 - 3 Always perform function tests prior to use.
 - 4 **Inspect the workplace.**
Know and understand the workplace inspection before going on to the next section.
 - 5 Only use the machine as it was intended.

Workplace Inspection Fundamentals

The workplace inspection helps the operator determine if the workplace is suitable for safe machine operation. It should be performed by the operator prior to moving the machine to the workplace.

It is the operator's responsibility to read and remember the workplace hazards, then watch for and avoid them while moving, setting up and operating the machine.

Workplace Inspection Checklist

Be aware of and avoid the following hazardous situations:

- drop-offs or holes
- bumps, floor obstructions or debris
- sloped surfaces
- unstable or slippery surfaces
- overhead obstructions and high voltage conductors
- hazardous locations
- inadequate surface support to withstand all load forces imposed by the machine
- wind and weather conditions
- the presence of unauthorized personnel
- other possible unsafe conditions

Inspections

Inspection for Decals with Symbols

Use the pictures on the next page to verify that all decals are legible and in place.

Below is a numerical list with quantities and descriptions.

Part No.	Decal Description	Qty
27204	Arrow – Blue	2
27205	Arrow – Yellow	2
27206	Triangle – Blue	4
27207	Triangle – Yellow	4
28159	Label – Diesel	1
28174	Label – Power to Platform, 230V	2
28235	Label – Power to Platform, 115V	2
40434	Label – Lanyard Anchorage Point	8
44981	Label – Air Line to Platform (option)	2
52475	Label – Transport Tie Down	6
65278	Caution – No Step	6
72086	Label – Lifting Point	4
82247	Label – 107 dB	1
82481	Label – Battery/Charger Safety	1
82487	Label – Read the Manual	2
97757	Label – Hydraulic Oil Level	1
97815	Label – Lower Mid-rail	1

Part No.	Decal Description	Qty
114248	Label – Tip-over Hazard, Tilt Alarm	1
114249	Label – Tip-over Hazard, Tires	4
114251	Label – Explosion Hazard	1
114252	Label – Tip-over Hazard, Limit Switches	3
133067	Label – Electrocutation Hazard	3
133163	Label – Function Override (Aircraft Protection Package)	1
133205	Label – Electrocutation/Burn Hazard	2
160424	Cosmetic – ZX-135/70	1
160425	Cosmetic – ZX-135/70	1
160578	Label – Maximum Capacity, Wind & Manual Force	1
160579	Label – Slope Rating	1
160682	Label – Wheel Load	1
160683	Label – Transport Diagram	1
161093	Label – Emergency Lowering Instructions	1
219958	Label – Tip-over, Crush Hazard	1
219974	Platform Control Panel	1
230985	Ground Control Panel	1
1263542	Label – Compartment Access	5
1263544	Bypass Key Switch	1
1263545	Instructions – Bypass Key Switch	1

 Shading indicates decal is hidden from view, i.e. under covers

Inspections

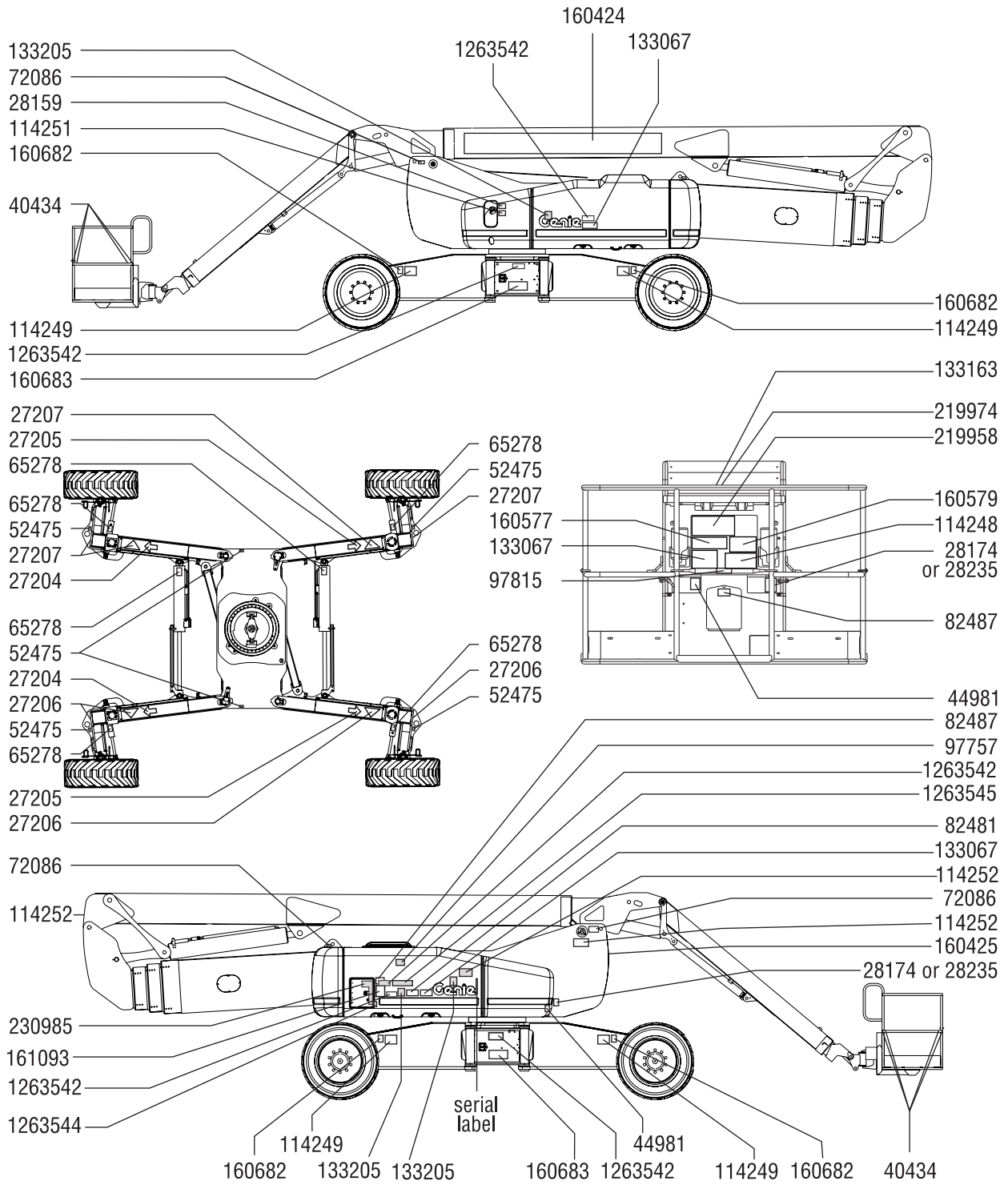

Operating Instructions



Do Not Operate Unless:

- You learn and practice the principles of safe machine operation contained in this operator's manual.
 - 1 Avoid hazardous situations.
 - 2 Always perform a pre-operation inspection.
 - 3 Always perform function tests prior to use.
 - 4 Inspect the workplace.
 - 5 **Only use the machine as it was intended.**

Fundamentals

The Operating Instructions section provides instructions for each aspect of machine operation. It is the operator's responsibility to follow all the safety rules and instructions in the operator's, safety and responsibilities manuals.

Using the machine for anything other than lifting personnel, along with their tools and materials, to an aerial work site is unsafe and dangerous.

Only trained and authorized personnel should be permitted to operate a machine. If more than one operator is expected to use a machine at different times in the same work shift, they must all be qualified operators and are all expected to follow all safety rules and instructions in the operator's, safety and responsibilities manuals. That means every new operator should perform a pre-operation inspection, function tests, and a workplace inspection before using the machine.

Operating Instructions

Starting the Engine

- 1 At the ground controls, turn the key switch to the desired position.
- 2 Be sure both ground and platform control red Emergency Stop buttons are pulled out to the on position.

Deutz models

- 1 Move the glow plug switch to either side. The glow plugs will turn on for 30 seconds.
- 2 Move the engine start toggle switch to either side. The engine start switch can be moved at any time while the glow plugs are on. If the engine fails to start or dies, the restart delay will disable the start switch for 3 seconds.



Perkins models

- 1 Move the glow plug switch to either side and hold.
- 2 Move the engine start toggle switch to either side. If the engine fails to start or dies, the restart delay will disable the start switch for 3 seconds.

If the engine fails to start after 15 seconds of cranking, determine the cause and repair any malfunction. Wait 60 seconds before trying to start again.

In cold conditions, -6°C and below, warm the engine for 5 minutes before operating to prevent hydraulic system damage.

In extreme cold conditions, -18°C and below, machines should be equipped with optional cold start kits. Attempting to start the engine when temperatures are below -18°C may require the use of a booster battery.

If the machine is stored for long periods of time in low temperatures (below 0°C) with the secondary boom raised and extended, the engine may not start due to system fault.

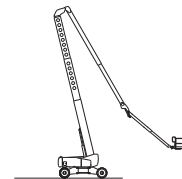

To remove the fault, move and hold the emergency power switch and activate the secondary boom up function until the secondary boom begins extending.

Operating Instructions

Emergency Stop

Push in the red Emergency Stop button to the off position at the ground controls or the platform controls to stop all machine functions and turn the engine off.

Repair any function that operates when either red Emergency Stop button is pushed in.

Selecting and operating the ground controls will override the platform red Emergency Stop button.

Emergency Controls

Use emergency power if the primary power source (engine) fails.

- 1 Turn the key switch to ground or platform control.
- 2 Pull out the red Emergency Stop button to the on position.
- 3 Press down the foot switch when using the controls from the platform.
- 4 Simultaneously hold the emergency power switch on and activate the desired function.



The drive function will not operate with emergency power.

To Extend and Retract Axles

- 1 Turn the key switch to platform control.
- 2 At the platform controls, press down the foot switch and move the drive control handle in either direction and move the axle switch in the appropriate direction.

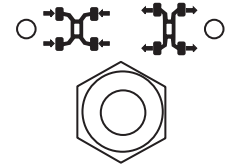

The indicator light will flash while the axles are moving and stay on when the axles are fully extended or retracted.

The axles can only be retracted if the primary and secondary booms are fully lowered and retracted and the platform is between the circle-end wheels.

Operation from Ground

- 1 Turn the key switch to ground control.
- 2 Pull out the red Emergency Stop button to the on position.
- 3 Start the engine.

To Position Platform

- 1 Push and hold a function enable/speed select button.
- 2 Push the appropriate function button according to the markings on the control panel.

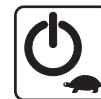

Drive and steer functions are not available from the ground controls.

Operating Instructions

Operation from Platform

- 1 Turn the key switch to platform control.
- 2 Pull out both ground and platform red Emergency Stop buttons to the on position.
- 3 Start the engine. Do not press down the foot switch when starting the engine.

To Position Platform

- 1 Press down the foot switch.
- 2 Slowly move the appropriate function control handle or thumb rocker switch or toggle switch according to the markings on the control panel.

To Steer

- 1 Press down the foot switch.
- 2 Select the steer mode by moving the steer mode switch. The indicator light next to the current steer mode will be on.

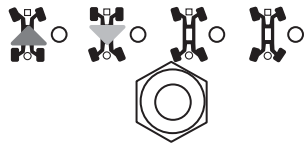

- 3 Slowly move the drive control handle in the direction indicated by blue or yellow triangles OR press the thumb rocker switch located on top of the drive control handle.



To Drive

- 1 Press down the foot switch.
- 2 Increase speed: Slowly move the drive control handle in the direction indicated by the blue or yellow arrows.

Decrease speed: Slowly move the drive control handle toward center.

Stop: Return the drive control handle to center or release the foot switch.



Use the color-coded direction arrows on the platform controls and the drive chassis to identify the direction the machine will travel.

Machine travel speed is restricted when the boom is raised or extended.

Use the color-coded direction arrows on the platform controls and the drive chassis to identify the direction the wheels will turn.

Operating Instructions

▲ Driving on a slope

Determine the uphill, downhill and side slope ratings for the machine and determine the slope grade.



Maximum slope rating, platform downhill (gradeability):
45% (24°)



Maximum slope rating, platform uphill:
30% (17°)



Maximum side slope rating:
25% (14°)

Note: Slope rating is subject to ground conditions and adequate traction. The term gradeability applies to the counterweight uphill configuration only.

Be sure the boom is below horizontal and the platform is between the circle-end wheels.

Move the drive speed select switch to machine on incline symbol.

To determine the slope grade:

Measure the slope with a digital inclinometer OR use the following procedure.

You will need:

- carpenter's level
- straight piece of wood, at least 1 m long
- tape measure

Lay the piece of wood on the slope.

At the downhill end, lay the level on the top edge of the piece of wood and lift the end until the piece of wood is level.

While holding the piece of wood level, measure the vertical distance from the bottom of the piece of wood to the ground.

Divide the tape measure distance (rise) by the length of the piece of wood (run) and multiply by 100.

Example:

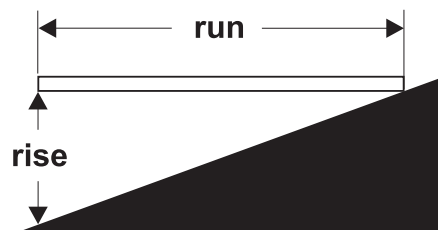

Piece of wood = 3.6 m

Run = 3.6 m

Rise = 0.3 m

$0.3 \text{ m} \div 3.6 \text{ m} = 0.083 \times 100 = 8.3\% \text{ grade}$

If the slope exceeds the maximum uphill, downhill or side slope rating, then the machine must be winched or transported up or down the slope. See Transport and Lifting section.

Operating Instructions

Drive Enable

Light on indicates that the primary boom has moved past either circle-end wheel and the drive function is turned off.



To drive, move the drive enable switch and slowly move the drive/steer control handle off center.

If the drive/steer control handle is not moved within two seconds of moving the drive enable switch, the drive function will not operate. Release and move the drive enable switch again.

Be aware that the machine may move in the opposite direction that the drive and steer controls are moved.

Always use the color-coded direction arrows on the platform controls and the drive chassis to identify the direction the machine will travel.

When the drive enable light is on, the axles cannot retract.

Engine Idle Select (rpm)

Select the engine idle (rpm) by pressing the engine idle select switch. The indicator light next to the current setting will be on.

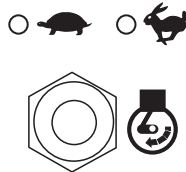

- Turtle symbol: low idle
- Rabbit symbol: high idle

Check Engine Light



Light on and engine stopped: Tag the machine and remove from service.

Light on and engine still running: Contact service personnel within 24 hours.

Operating Envelope Indicator Lights

The operating envelope indicator lights will come on to notify the operator that a function has been interrupted and/or an action is required by the operator.

Lower/Retract Secondary Boom indicator light flashing: Lower/retract the secondary boom until the indicator light is off.



Lower Primary Boom indicator light flashing: Lower the primary boom until the indicator light is off.



Platform Not Level indicator light flashing: The tilt alarm will be sounding when this light is flashing. The Platform Level toggle switch will only work in the direction that will level the platform. Level the platform until the indicator light is off.



Operating Instructions

Platform Out of Level (P22 code)

Bypass key position to be used to level the platform if ground control display shows platform out of level (P22) and platform level controls do not work.

To operate:

- 1 Turn the engine off.
 - 2 Turn the main key switch to ground control. Remove the key from the main key switch and insert the key into the bypass/recovery key switch.
 - 3 Turn the bypass/recovery key switch to the bypass position.
- 

P22
- 4 Using emergency power, operate the platform level button to level the platform.
 - 5 Turn the bypass/recovery key switch to the run position.
 - 6 Remove the key from the bypass/recovery key switch and insert the key into the main key switch.
 - 7 Push in and then pull out the red Emergency Stop button.
 - 8 If the P22 code is still visible, tag and remove the machine from service until the fault has been corrected by a qualified service technician.

Platform Out of Level (Platform Level > 15 Degrees Fault)

If ground control display shows PLATFORM LEVEL > 15 DEGREES FAULT and the platform level controls do not work, the machine will need to be recovered by trained and authorized personnel or a qualified service technician.

Platform Overload Indicator Light



Light flashing indicates the platform is overloaded and no functions will operate.

Remove weight from the platform until the light goes off.

Overload Recovery

If the ground controls LCD screen displays OVERLOAD RECOVERY, the emergency lowering system has been used while the platform was overloaded. For information on how to reset this message, please consult the appropriate Genie Service Manual.

Generator (if equipped)

To operate the generator, move the generator switch. The indicator light will come on and the engine will continue to run.

Plug a power tool into the power to platform GFCI outlet.

To turn off the generator, move the generator switch. The indicator light will turn off.

Operating Instructions

LCD Screen (if equipped)

The LCD screen displays hour meter, voltage, oil pressure and coolant temperature. The screen also displays fault codes and other service information.

Perkins Engine

Machines equipped with Perkins 854F-34T Diesel engines have a regeneration mode that should run automatically when needed.

LCD will display REGEN FORCED and WARNING HIGH EXHAUST SYSTEM TEMP when the regeneration mode is running. No service required.

Machine Not Level Indicator Light



If the tilt alarm sounds when the platform is raised, the Machine Not Level indicator light will come on and the drive function in one or both directions will not operate. Identify the condition of the boom on the slope as shown below. Follow the steps to lower the boom before moving to a firm, level surface. Do not rotate the boom while lowering.

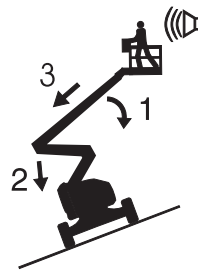

If the tilt alarm sounds with the platform uphill:

- 1 Lower the primary boom.
- 2 Lower the secondary boom.
- 3 Retract the primary boom.

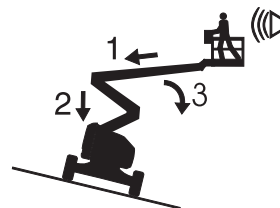

If the tilt alarm sounds with the platform downhill:

- 1 Retract the primary boom.
- 2 Lower the secondary boom.
- 3 Lower the primary boom.

Operating Instructions

Aircraft Protection Package (if equipped)



If the platform bumper comes into contact with an object, the machine will shut down and no functions will operate.

- 1 Start the engine.
- 2 Press down the foot switch.
- 3 Move and hold the aircraft protection override switch.
- 4 Move the appropriate function control handle or toggle switch to move the machine away from aircraft components.

After Each Use

- 1 Select a safe parking location—firm level surface, clear of obstruction and traffic.
- 2 Retract and lower the boom to the stowed position.
- 3 Rotate the turntable so that the boom is between the non-steer wheels.
- 4 Turn the key switch to the off position and remove the key to secure from unauthorized use.

Transport and Lifting Instructions



Observe and Obey:

- ☑ Genie provides this securement information as a recommendation. Drivers are solely responsible for making sure machines are properly secured and the correct trailer is selected pursuant to US Department of Transportation regulations, other localized regulations, and their company policy.
- ☑ Genie customers needing to containerize any lift or Genie product should source a qualified freight forwarder with expertise in preparing, loading and securing construction and lifting equipment for international shipment.
- ☑ Only qualified aerial lift operators should move the machine on or off the truck.
- ☑ The transport vehicle must be parked on a level surface.
- ☑ The transport vehicle must be secured to prevent rolling while the machine is being loaded.
- ☑ Be sure the vehicle capacity, loading surfaces and chains or straps are sufficient to withstand the machine weight. Genie lifts are very heavy relative to their size. See the serial label for the machine weight.

- ☑ Be sure the turntable is secured with the turntable rotation lock before transporting. Be sure to unlock the turntable for operation.
- ☑ Do not drive the machine on a slope that exceeds the uphill, downhill or side slope rating. See Driving on a Slope in the Operating Instructions section.
- ☑ If the slope of the transport vehicle bed exceeds the maximum slope rating, the machine must be loaded and unloaded using a winch as described in the brake release operation.

Free-wheel Configuration for Winching

Chock the wheels to prevent the machine from rolling.

Release the wheel brakes by turning over all four drive hub disconnect caps.

Be sure the winch line is properly secured to the drive chassis tie points and the path is clear of all obstructions.

Reverse the procedures described to re-engage the brakes.

Note: The pump free-wheel valve should always remain closed.

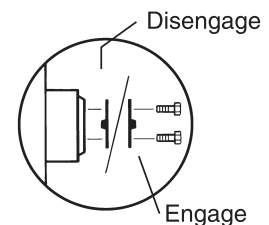

Transport and Lifting Instructions

Securing to Truck or Trailer for Transit

Always use the turntable rotation lock pin each time the machine is transported.

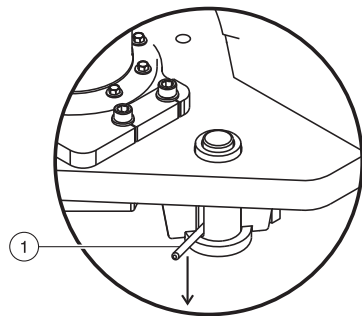

1 Turntable rotation lock pin

Turn the key switch to the off position and remove the key before transporting.

Inspect the entire machine for loose or unsecured items.

Securing the Chassis

Use chains of ample load capacity.

Use a minimum of 6 chains.

Adjust the rigging to prevent damage to the chains.

Securing the Platform

Place a block under the platform rotator. Do not allow the block to contact the platform cylinder.

Secure the platform with a nylon strap placed through the lower platform support. Do not use excessive downward force when securing the boom section.

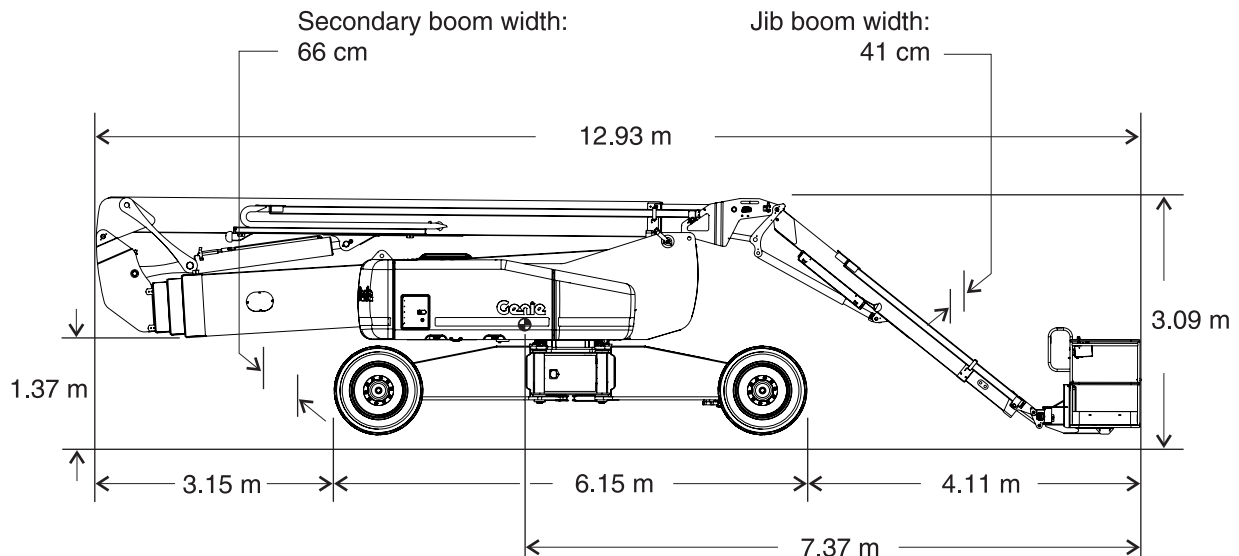
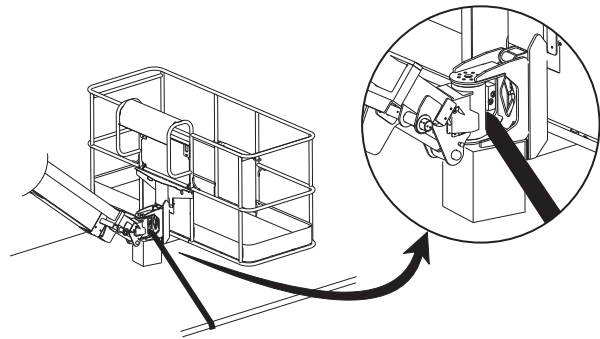

Transport and Lifting Instructions



Observe and Obey:

- ☑ Only qualified riggers should rig the machine.
- ☑ Only certified crane operators should lift the machine and only in accordance with the applicable crane regulations.
- ☑ Be sure the crane capacity, loading surfaces and straps or lines are sufficient to withstand the machine weight. See the serial label for the machine weight.

Lifting Instructions

Fully lower and retract the boom. Fully lower the jib (if equipped). Remove all loose items on the machine.

Determine the center of gravity of your machine using the table and the picture on this page.

Attach the rigging only to the designated lifting points on the machine. There are four lifting points on the machine, one on each axle.

Adjust the rigging to prevent damage to the machine and to keep the machine level.

Center of gravity	X Axis	Y Axis
ZX-135/70	1.85 m	1.03 m

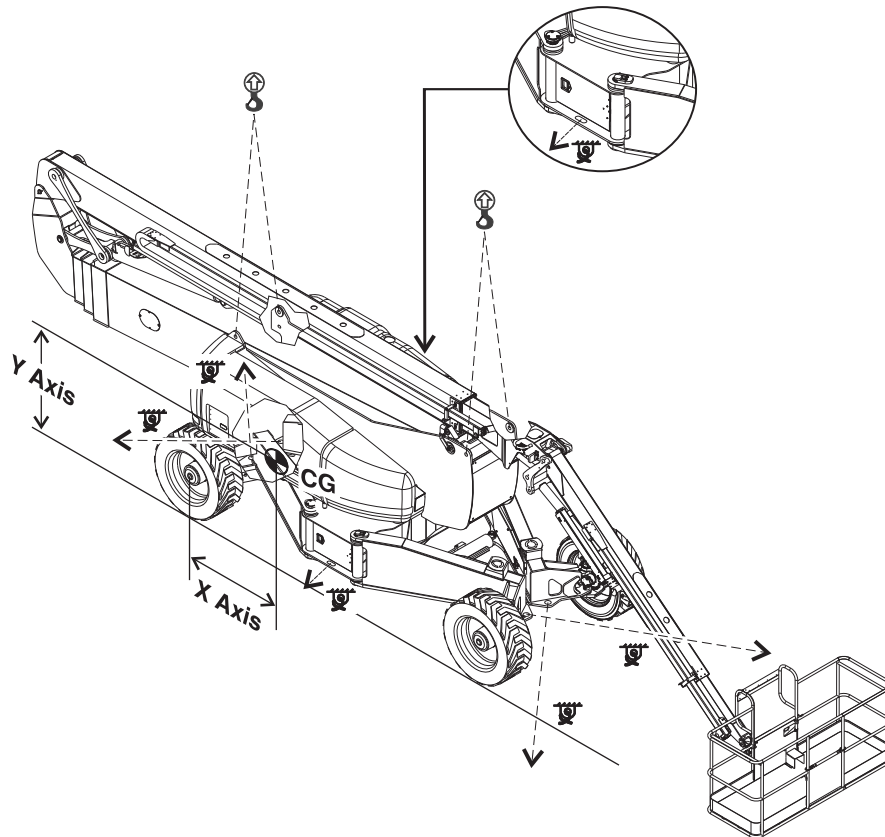

Maintenance



Observe and Obey:

- ☑ Only routine maintenance items specified in this manual shall be performed by the operator.
- ☑ Scheduled maintenance inspections shall be completed by qualified service technicians, according to the manufacturer's specifications and the requirements specified in the responsibilities manual.
- ☑ Dispose of material in accordance with governmental regulations.
- ☑ Use only Genie approved replacement parts.

Maintenance Symbols Legend

The following symbols have been used in this manual to help communicate the intent of the instructions. When one or more of the symbols appear at the beginning of a maintenance procedure, it conveys the meaning below.



Indicates that tools will be required to perform this procedure.



Indicates that new parts will be required to perform this procedure.



Indicates that a cold engine is required before performing this procedure.

Check the Engine Oil Level



Maintaining the proper engine oil level is essential to good engine performance and service life. Operating the machine with an improper oil level can damage engine components.

Note: Check the oil level with the engine off.

- 1 Check the oil level dipstick. Add oil as needed.

Perkins 1104D-44T Engine

Oil type	15W-40
Oil type - cold conditions	10W-30

Deutz TD2011 L04i Engine

Oil type	15W-40
Oil type - cold conditions	5W-30

Perkins 854F-34T Engine

Oil type	15W-40
Oil type - cold conditions	5W-30

Deutz TD2.9L Engine

Oil type	15W-40
Oil type - cold conditions	5W-30

Maintenance

Diesel Fuel Requirements



Satisfactory engine performance is dependent on the use of a good quality fuel. The use of a good quality fuel will give the following result: long engine life and acceptable exhaust emissions levels.

Minimum diesel fuel requirements for each engine are listed below.

Perkins 1104D-44T Engine	
Fuel Type	Low Sulfur Diesel (LSD)
Perkins 854F-34T Engine	
Fuel Type	Ultra Low Sulfur Diesel (ULSD)
Deutz TD2011 L04i Engine	
Fuel Type	Low Sulfur Diesel (LSD)
Deutz TD2.9L Engine	
Fuel Type	Ultra Low Sulfur Diesel (ULSD)

Check the Hydraulic Oil Level



Maintaining the hydraulic oil at the proper level is essential to machine operation. Improper hydraulic oil levels can damage hydraulic components. Daily checks allow the inspector to identify changes in oil level that might indicate the presence of hydraulic system problems.

- 1 Be sure that the boom is in the stowed position and the engine is off.
- 2 Visually inspect the sight gauge located on the side of the hydraulic oil tank.
- ⊙ Result: The hydraulic oil level should be between the two marks on the decal next to the sight gauge.
- 3 Add oil as needed. Do not overfill.



Maximum oil level



Minimum oil level

Hydraulic oil specifications

Hydraulic oil type	Chevron Rando HD equivalent
--------------------	-----------------------------

Maintenance

Check the Engine Coolant Level – Liquid Cooled Models



Maintaining the engine coolant at the proper level is essential to engine service life. Improper coolant level will affect the engine's cooling capability and damage engine components. Daily checks will allow the inspector to identify changes in coolant level that might indicate cooling system problems.

- 1 Check the fluid level in the coolant recovery tank. Add fluid as needed.
- ⦿ Result: The fluid level should be in the NORMAL range.
 - ▲ Bodily Injury Hazard. Fluids in the radiator are under pressure and extremely hot. Use caution when removing cap and adding fluids.

Check the Batteries



Proper battery condition is essential to good machine performance and operational safety. Improper fluid levels or damaged cables and connections can result in component damage and hazardous conditions.

- ▲ Electrocuting hazard. Contact with hot or live circuits may result in death or serious injury. Remove all rings, watches and other jewelry.
 - ▲ Bodily injury hazard. Batteries contain acid. Avoid spilling or contacting battery acid. Neutralize battery acid spills with baking soda and water.
- 1 Put on protective clothing and eye wear.
 - 2 Be sure that the battery cable connections are tight and free of corrosion.
 - 3 Be sure that the battery hold-down brackets are in place and secure.

Note: Adding terminal protectors and a corrosion preventative sealant will help eliminate the corrosion on the battery terminals and cables.

Maintenance

Scheduled Maintenance

Maintenance performed quarterly, annually and every two years must be completed by a person trained and qualified to perform maintenance on this machine according to the procedures found in the service manual for this machine.

Machines that have been out of service for more than three months must receive the quarterly inspection before they are put back into service.

Specifications

Model	ZX-135/70
Height, working maximum	42.9 m
Height, platform maximum	41.4 m
Height, stowed maximum	3.1 m
Horizontal reach, maximum	21.3 m
Width, axles retracted	2.5 m
Width, axles extended	5 m
Length, stowed	12.9 m
Maximum load capacity	272 kg
Maximum wind speed	12.5 m/s
Wheelbase, axles extended	2.2 m
Wheelbase, axles retracted	5 m
Ground clearance	38 cm
Turning radius, axles extended	
Inside	3 m
Outside	6.3 m
Turning radius, axles retracted	
Inside	7.3 m
Outside	8.6 m
Turntable rotation (degrees)	360° continuous
Turntable tailswing, secondary boom lowered	4.3 m
Turntable tailswing, secondary boom raised	0.74 m
Controls	12V DC proportional
Platform dimensions, 1.8 m (length x width)	182 x 76 cm
Platform dimensions, 2.4 m (length x width)	244 x 91 cm
Platform leveling	self-leveling
Platform rotation	160°
AC outlet in platform	standard
Fuel tank capacity	151 liters
Hydraulic pressure, maximum (boom functions)	203 bar
Hydraulic pressure, maximum (auxiliary power unit)	218 bar

System voltage	12V
Tire size	445/65 D22.5 or 445D50/710, 18 ply FF
Weight	20,457 kg
(Machine weights vary with option configurations. See serial label for specific machine weight.)	

Airborne noise emissions

Sound pressure level at ground workstation	<85 dBA
Sound pressure level at platform workstation	<74 dBA
Total vibration value to which the hand/arm system is subjected does not exceed 2.5 m/s ² .	

Highest root mean square value of weighted acceleration to which the whole body is subjected does not exceed 0.5 m/s².

Maximum slope rating, stowed position, 4WD

Counterweight uphill	45%	24°
Counterweight downhill	30%	17°
Side slope	25%	14°

Note: Slope rating is subject to ground conditions and adequate traction.

Drive speeds

Drive speed, stowed	4.8 km/h 12.2 m/9.1 sec
Drive speed, raised or extended	1.1 km/h 12.2m/40 sec
Drive speed, raised and extended	0.6 km/h 12.2 m/68 sec

Floor loading information

Tire load maximum	9,979 kg
Tire contact pressure	5.77 kg/cm ² 566 kPa
Occupied floor pressure	1,411 kg/m ² 13.84 kPa

Note: Floor loading information is approximate and does not incorporate different option configurations. It should be used only with adequate safety factors.

Continuous improvement of our products is a Genie policy. Product specifications are subject to change without notice or obligation.

Specifications

ZX-135/70 Range of Motion Chart

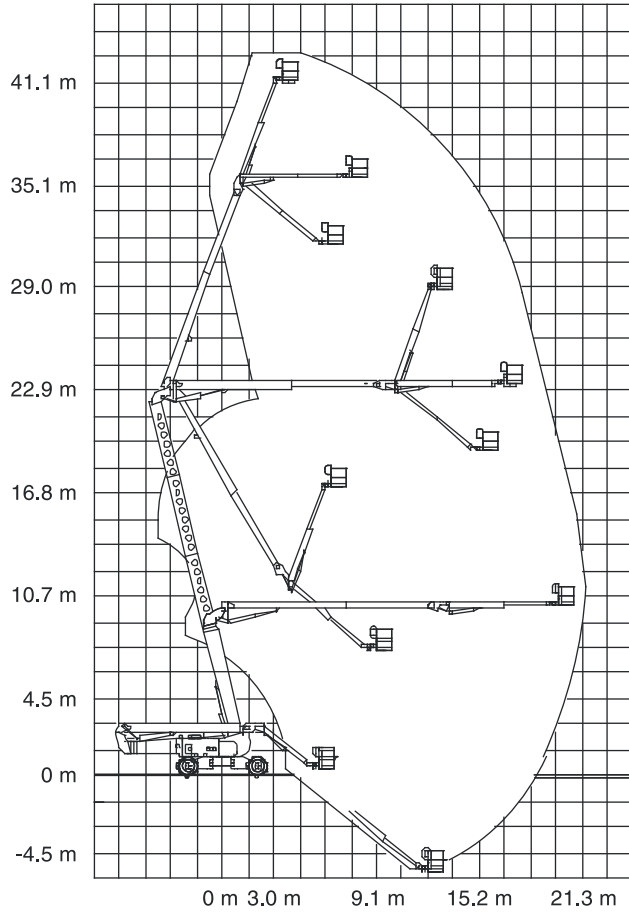

www.genielift.com

Distributed By: