



nifty



**ADVANCED
ACCESS PLATFORMS**

Heightrider

Operating & Safety Instructions

HR28 (SP85) SERIES

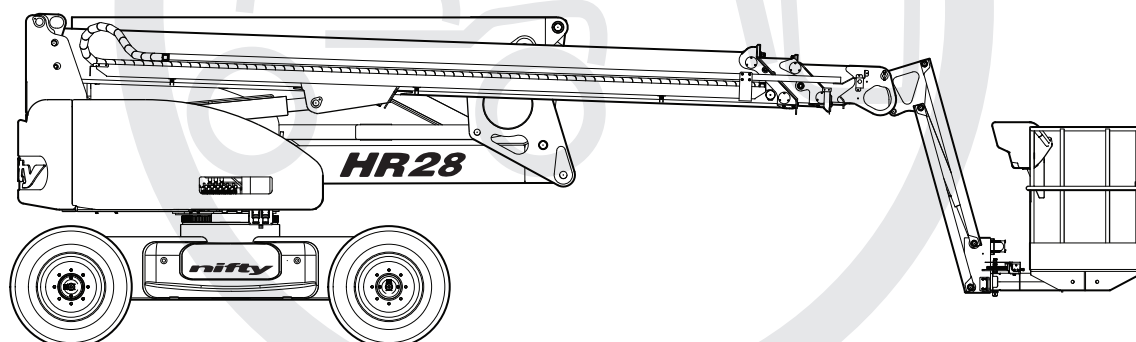

niftylift.com
info@niftylift.com

Manufactured by:
Niftylift Limited
Chalkdell Drive
Shenley Wood
Milton Keynes
MK5 6GF
England



www.niftylift.com
e-mail: info@niftylift.com
Tel: +44 (0)1908 223456
Fax: +44 (0)1908 312733

M50441/04

Table of Contents

1	Introduction and General Information	2
1.1	FOREWORD	2
1.2	SCOPE.....	3
1.3	INTRODUCING THE HEIGHT RIDER SELF-PROPELLED (SP) SERIES	3
1.4	GENERAL SPECIFICATION.....	4
1.5	IDENTIFICATION (UK PLATE).....	5
1.6	EC DECLARATION OF CONFORMITY (Typical)	7
2	Safety	8
2.1	MANDATORY PRECAUTIONS	8
2.2	ENVIRONMENTAL LIMITATIONS.....	11
2.3	NOISE AND VIBRATION	12
2.4	TEST REPORT	12
3	Preparation and Inspection	13
3.1	UNPACKING.....	13
3.2	PREPARATION FOR USE	13
3.3	PRE-OPERATIONAL SAFETY CHECK SCHEDULES	14
3.4	PLACARD, DECALS & INSTALLATION (UK SPEC)	16
3.5	TORQUE REQUIREMENTS.....	19
4	Operation	20
4.1	CONTROL CIRCUIT COMPONENTS	20
4.2	GROUND CONTROL OPERATION.....	23
4.3	PLATFORM CONTROL OPERATION	27
4.4	DRIVING CONTROLS.....	34
4.5	CAGE WEIGH SYSTEM.....	35
4.6	BATTERIES AND CHARGING	36
4.7	TRANSPORTING, TOWING, CRANEAGE, STORAGE AND SETTING TO WORK..	39
5	Emergency Controls	42
5.1	GENERAL	42
5.2	IN THE EVENT OF AN INCAPACITATED OPERATOR	42
5.3	IN THE EVENT OF MACHINE FAILURE	42
5.4	INCIDENT NOTIFICATION.....	42
6	Responsibilities	43
6.1	CHANGES IN OWNERSHIP	43
6.2	MANUAL OF RESPONSIBILITIES (USA only)	43
6.3	INSPECTION/SERVICE/PRE-HIRE CHECK LIST	44

Appendix A	46
Error Codes	43

1 Introduction and General Information

1.1 FOREWORD

The purpose of these manuals is to provide the customer with appropriate safety operating and maintenance instructions essential for proper machine operation.

All information in these manuals should be **READ** and fully **UNDERSTOOD** before any attempt is made to operate the machine. **THESE MANUALS ARE VERY IMPORTANT TOOLS** - Keep them with the machine at all times.

The manufacturer has no direct control over machine application and use, therefore conformance with good safety practices is the responsibility of the user and his operating personnel.

All information in these manuals is based on the use of the machine under proper operating conditions. Alteration and/or modification of the machine are strictly forbidden.

One of the most important facts to remember is that any equipment is only as safe as those who operate it.

DANGER, WARNING, CAUTION, IMPORTANT, INSTRUCTIONS AND NOTICE

Any place these topics may appear, either in this manual or on the machine, they are defined as follows:

DANGER: If not correctly followed there is a high probability of serious injury or death to personnel.

WARNING OR CAUTION: If not correctly followed there is some possibility of serious injury or death to personnel.



THE '**SAFETY ALERT**' SYMBOL IS USED TO CALL ATTENTION TO POTENTIAL HAZARDS THAT MAY LEAD TO SERIOUS INJURY OR DEATH, IF IGNORED.

IMPORTANT AND INSTRUCTIONS: Denotes procedures essential to safe operation and prevention of damage to or destruction of the machine.

NOTICE: Indicates general safety rules and/or procedures relating to the machine.

It is the owner's/user's responsibility to know and comply with all applicable rules, regulations, laws, codes and any other requirements applicable to the safe use of this equipment.

1.2 SCOPE

These operating instructions contain all the necessary information required to allow the safe operation of any Niftylift Height Rider 28 (SP85 in the USA), powered by diesel (D) and DC electric (E).

For further technical information, circuit diagrams and specific instructions for all maintenance which may need to be carried out by specialist trained personnel, see the associated Workshop and Parts manual for your model of Niftylift Height Rider.

1.3 INTRODUCING THE HEIGHT RIDER SELF-PROPELLED (SP) SERIES

Please note at the time of going to press all information, illustrations, details and descriptions contained herein are valid. Niftylift reserves the right to change, modify, or improve its products without any obligations to install them on previously manufactured machines.

If, after reading this manual you require further information, please do not hesitate to contact us.

Niftylift Ltd, Fingle Drive, Stonebridge, Milton Keynes MK13 0ER, Great Britain
Tel: +44 (0) 1908 223456 Fax: +44 (0) 1908 312733

Niftylift Inc, 1525 S. Buncombe Road, Greer, SC 29651 USA
Tel: +01 864 968 8881 Fax: +01 864 968 8836

Nifty Pty Ltd, 11 Kennington Drive, Tomago, NSW 2322, Australia
Tel: +61 (0) 2 4964 9765 Fax: +61 (0) 2 4964 9714

Driven from the platform, the Niftylift Height Rider 28 (SP85) is an extremely versatile articulated boom platform of unique and simple design. The HR28 can place two or three persons and their tools at a height of 28.00m (91ft 10in) or an outreach of 18.90m (62ft).

The booms are mounted via a 360° powered swing mechanism onto a compact narrow base with a tight turning circle that ensures excellent manoeuvrability and maximum efficiency.

High traction tyres and powerful hydraulic wheel motors give unsurpassed performance with the option of fast drive speed when the booms are in the stowed position. Automatic braking and audible alarms activated by a tilt sensor, help to prevent the operator from working on unsafe terrain whilst elevated.

A digital control system gives smooth, reliable movement of the platform and maximum reliability in the harshest environments.

Models include the following:

HYBRID: - DIESEL & BATTERY

D: - DIESEL

nifty Height Rider/SP Series

Operating & Safety Instructions

1.4 GENERAL SPECIFICATION

FEATURE	HR28 (SP85)	
MAXIMUM HEIGHT - WORKING	28.00 m 91 ft 10 in	
MAXIMUM HEIGHT - PLATFORM	26.00 m 85 ft 4 in	
MAXIMUM OUTREACH	18.90 m 62 ft 0 in	
MAXIMUM HEIGHT – STOWED	2.72 m 8 ft 11 in	
MAXIMUM WIDTH	2.49 m 8 ft 2 in	
MAXIMUM LENGTH – STOWED	9.3 m/7.3 m (cage tucked) 30 ft 5 in/23 ft 11 in	
PLATFORM CAPACITY	280 kg 617 lbs	
MAXIMUM PERSONS IN PLATFORM	(2-man) 2	(3-man) 3
WHEELBASE	2.60 m 8 ft 6 in	
TURNING RADIUS – OUTSIDE	5.90 m 19 ft 4 in	
TURRET ROTATION	Continuous	
TURRET TAIL SWING	0.49 m 1ft 7 in	
TRAVEL SPEED	Hybrid 0-4.5 km/h 0-2.8 mph	Diesel 0-6 km/h 0-3.7 mph
PLATFORM SIZE	2.40 m x 0.90 m 7 ft 10 in x 2 ft 11 in	
CONTROLS	Digital	
HYDRAULIC PRESSURE	207 bar (Booms) 315 bar (Drive)	
TYRES	Foam filled	
GRADE-ABILITY	45%	
MINIMUM VEHICLE WEIGHT	(2-man) 14,323 kg 31,577 lbs	(3-man) 14,633 kg 32,260 lbs
MAXIMUM GROUND PRESSURE	0.111 kN/cm ² 23177 lbs/ft ²	
POWER SOURCE	Hybrid - Kubota D1105 diesel engine, Schabmuller TSA200 electric motor and 12 x 6V 395 Ah AGM Batteries Diesel - Kohler KDI1903TCR engine	

1.5 IDENTIFICATION (UK PLATE)

			
NIFTYLIFT LTD. FINGLE DRIVE, STONEBRIDGE MILTON KEYNES MK13 0ER ENGLAND TEL 01908 223456 : FAX 01908 312733 e-mail : info@niftylift.com			
SERIAL No			
TYPE			
YEAR OF MANUFACTURE			
WEIGHT			kg
RATED LOAD	PERSONS	+	kg
MAXIMUM SAFE WORKING LOAD			kg
MAXIMUM PULL			N
MAXIMUM WIND SPEED			m/s
MAX. ALLOWABLE INCLINATION			Deg.
MAXIMUM HYDRAULIC PRESSURE			bar
MAXIMUM VOLTAGE			V
AMPS			A
ELEC. CCT D	ISSUE		
HYD. CCT D	ISSUE		
			P10205

This manufacturer's plate is attached to the chassis on each machine at the time of manufacture on every Niftylift. Please ensure all sections have been stamped and are legible.

nifty Height Rider/SP Series

Operating & Safety Instructions

1.5a IDENTIFICATION (USA PLATE)

	
NIFTYLIFT LTD. RINGLE DRIVE, STONEBRIDGE MILTON KEYNES MK13 0ER GREAT BRITAIN TEL (01144) 1908 223466 : FAX (01144) 1908 312733 e-mail : info@niftylift.com	
THIS WORK PLATFORM COMPLIES WITH ANSI STANDARD A 92-	
MODEL	
SERIAL NO	
YEAR OF MANUFACTURE	
CAPACITY RATING	LBS
PLATFORM HEIGHT	FEET
GROSS WEIGHT	LBS
MAXIMUM HYDRAULIC PRESSURE	PSI
MAXIMUM VOLTAGE	V
AMPS	A
ELEC. CCT D	ISSUE
HYD. CCT D	ISSUE
P11497	

This manufacturer's plate is attached to the chassis on each machine at the time of manufacture on every Niftylift. Please ensure all sections have been stamped and are legible.

1.6 EC DECLARATION OF CONFORMITY (Typical)



EC DECLARATION OF CONFORMITY

MANUFACTURER AND PERSON RESPONSIBLE FOR DOCUMENTATION: **NIFTYLIFT LTD
MALCOLM NORTH**

ADDRESS: **CHALKDELL DRIVE,
SHENLEY WOOD,
MILTON KEYNES,
MK5 6GF
ENGLAND.**

MACHINE TYPE: **MOBILE ELEVATING WORK PLATFORM**

MODEL TYPE:

SERIAL NUMBER:

NOTIFIED BODY: **TUV NORD CERT GmbH**

NOTIFIED BODY NUMBER: **0044**

ADDRESS: **POSTFACH 10 32 61
D-45141 ESSEN
GERMANY**

CERTIFICATE NUMBER:

APPLICABLE STANDARDS: **EN 280:2013
DIN EN 60204-1, 2006/42/EC**

We hereby declare that the above mentioned machine conforms with the requirements of the Machinery Directive, 2006/42/EC and EMC Directive 2004/108/EC

SIGNED:  DATE:

NAME: **Malcolm North** POSITION: **Engineering Manager**

NOTE:
THIS DECLARATION CONFORMS WITH THE REQUIREMENTS OF ANNEX II-1.A OF THE COUNCIL DIRECTIVE 2006/42/EC. ANY MODIFICATIONS TO THE ABOVE MENTIONED MACHINE WILL INVALIDATE THIS DECLARATION, AND THE MACHINE'S APPROVAL.

2 Safety

2.1 MANDATORY PRECAUTIONS

When operating your Niftylift, your safety is of utmost concern. In order to fully appreciate all aspects of the machine's operation it should be ensured that each operator has **READ** and fully **UNDERSTOOD** the relevant manual covering machine use, maintenance and servicing. If any doubts exist concerning any points covered in your manual, contact your local dealer or Niftylift Ltd.

Before using any Niftylift, thoroughly inspect the machine for damage or deformation to all major components. Likewise, check the control systems for hydraulic leaks, damaged hoses, cable faults or loose covers to electrical components. At no time should damaged or faulty equipment be used - Correct all defects before putting the platform to work. If in doubt, contact your local dealer or Niftylift Ltd (see front cover for address).



THE MANUFACTURER HAS NO DIRECT CONTROL OVER THE MACHINE APPLICATION AND USE. THEREFORE CONFORMANCE WITH GOOD SAFETY PRACTICES IS THE RESPONSIBILITY OF THE USER AND HIS OPERATING PERSONNEL. FAILURE TO UNDERSTAND AND FOLLOW ALL SAFETY RULES COULD RESULT IN SERIOUS INJURY OR DEATH.

- 2.1.1** Only trained persons are permitted to operate the Niftylift.
- 2.1.2** Always operate the Niftylift in full accordance with the manufacturer's Operating & Safety Instructions for that model.
- 2.1.3** Before use each day and at the beginning of each shift the Niftylift shall be given a visual inspection and functional test including, but not limited to, operating and emergency controls, safety devices, personal protective clothing, including fall protection, air, hydraulic and fuel system leaks, cables and wiring harness, loose or missing parts, tyres and wheels, placards, warnings, control markings and Operating and Safety Manuals, guards and guard rail systems and all other items specified by the manufacturer.
- 2.1.4** Any problems or malfunctions that affect operational safety must be repaired prior to use of the platform, with specific regard to any safety components refer to the Parts Manual for part numbers and details. If in doubt, contact Niftylift Ltd (Details on page 3). **Ensure wheels are chocked before carrying out any maintenance that involves gearbox disengagement as described in Section 4.7.2**
- 2.1.5** Always ensure that all warning labels, instructions, placards, control markings and Safety Manuals are intact and clearly legible. If replacements are required contact your local dealer or Niftylift. Always observe and obey safety and operating instructions on such labels.
- 2.1.6** Do not alter, modify, or disable in any way the controls, safety devices, interlocks or any other part of the machine.
- 2.1.7** Before the Niftylift is used and during use the user shall check the area in which it is to be used for possible hazards such as, but not limited to, uneven ground drop-offs, holes, bumps, obstructions, debris, floor and overhead obstructions, high voltage conductors, wind and weather, unauthorised persons and any other possibly hazardous conditions.

- 2.1.8** This machine contains several hazardous substances such as but not limited to: Battery acid, Hydraulic Fluid, Engine Coolant, Antifreeze, LPG, Diesel Fuel, Petrol, Engine Oil, Grease, and Gasoline.
- 2.1.9** Covers and canopies should remain closed when the machine is in operation. Only trained personnel should carry out maintenance on the machine, ensuring at all times they protect themselves from electrical, heat and mechanical hazards.
- 2.1.10** Never exceed the maximum platform capacity, as indicated on the decals and machine serial plate.
- 2.1.11** Only operate the Niftylift on a firm, level surface.
- 2.1.12** Never position any part of the Niftylift inside the **Minimum approach distances** (MAD) to above-ground electrical conductors as listed in the table below. (Reference ISO 18893:2014).

Voltage range (kV)	MAD (m)
<0.7	1
≥0.7 to 7	1.2
>7 to 50	3
>50 to 220	4
>220 to 500	5
>500 to 750	10
>750 to 1000	13
>1000 to 1250	16

**THIS MACHINE IS NOT INSULATED.**

If in doubt, contact the local appropriate governing authority.

- 2.1.13** On entering the platform ensure that the drop down entry bar is closed afterwards.
- 2.1.14** Use of an approved safety belt and lanyard, hard hat and appropriate safety clothing is mandatory. Fasten harness to designated harness securing points within the platform and do not remove until leaving the platform whilst in the stowed position.
- 2.1.15**  Always remain standing within the platform. Do not attempt to increase your height or reach by standing and/or climbing on the platform guard rails or any other object. **KEEP YOUR FEET ON THE PLATFORM FLOOR.** Do not sit, stand or climb on the guard rail, mid rail or boom linkage. Use of planks, ladders or any other devices on the Niftylift for achieving additional height or reach shall be prohibited.
- 2.1.16** Do not use the platform levelling system to artificially increase the outreach of the platform. Never use boards or ladders in the platform to achieve the same result.
- 2.1.17** Do not use the platform to lift overhanging or bulky items that may exceed the maximum capacity or carry objects that may increase the wind loading on the platform. (e.g. Notice boards etc.)
- 2.1.18** The Niftylift shall not be operated from a position on trucks, trailers, railway cars, floating vessels, scaffolds or similar equipment unless the application is approved in writing by Niftylift Ltd in Great Britain.

nifty Height Rider/SP Series

Operating & Safety Instructions

- 2.1.19** Always check that the area below and around the platform is clear of personnel and obstructions before lowering or slewing. Care should be taken when slewing out into areas where there may be passing traffic. Use barriers to control traffic flow or prevent access to the machine.
- 2.1.20** Stunt driving and horseplay, on or around the Niftylift, shall not be permitted.
- 2.1.21** When other moving equipment and vehicles are present, special precautions shall be taken to comply with local ordinances or safety standards established for the work place. Warnings, such as but not limited to, flags, roped off areas, flashing lights and barricades shall be used.
- 2.1.22** Before and during driving while the platform is elevated the operator shall maintain a clear view of the path of travel, maintain a safe distance from obstacles, debris, drop offs, holes, depressions, ramps and other hazards to ensure safe elevated travel. Maintain a safe distance from overhead obstacles.
- 2.1.23** Under all travel conditions the operator shall limit travel speed according to conditions of ground surface, congestion, visibility, slope, location of personnel and other factors causing hazards of collision or injury to personnel.
- 2.1.24** The aerial platform shall not be driven on grades, side slopes, or ramps exceeding those for which the aerial platform is rated by the manufacturer.
- 2.1.25** It shall be the responsibility of the user to determine the hazard classification of any particular atmosphere or location. Aerial platforms operated in hazardous locations shall be approved and suitable for the duty. (See ANSI/NFPA 505 where applicable).
- 2.1.26** The operator shall immediately report to his supervisor any potentially hazardous location(s) (environment) which become evident during operation.
- 2.1.27** If an operator encounters any suspected malfunction of the Niftylift or any hazard or potentially unsafe condition relating to capacity, intended use or safe operation, he shall cease operation of the Niftylift and request further information as to safe operation from his management, or owner, dealer or manufacturer before further operation of the Niftylift.
- 2.1.28** The operator shall immediately report to his superior any problems or malfunctions of the Niftylift, which becomes evident during operation. Any problems or malfunctions that affect the safety of operation shall be repaired prior to continued use.
- 2.1.29** The boom and platform of the Niftylift shall not be used to jack the wheels off the ground.
- 2.1.30** The Niftylift shall not be used as a crane.
- 2.1.31** The Niftylift shall not be positioned against another object to steady the platform.
- 2.1.32** Care should be taken to prevent rope, electric cords, and hoses from becoming entangled in the aerial platform.
- 2.1.33** Batteries shall be recharged in a well-ventilated area free of flame, sparks, or other hazards, which may cause explosion. Highly explosive hydrogen gas is produced during the charging process.
- 2.1.34** If the platform or elevating assembly becomes caught, snagged or otherwise prevented from normal motion by adjacent structure or other obstacles, such that control reversal does not free the platform, all personnel shall be removed from the platform safely before attempts are made to free the platform using ground controls.

2.1.35



When the machine is not in use always stow the booms correctly. **NEVER LEAVE THE KEYS IN THE MACHINE**, if it is to be left for any period of time. Use wheel chocks if leaving on an incline.

2.1.36

The engine must be shut down while fuel tanks are being filled. Fuelling must be done in a well-ventilated area free of flame, sparks or any other hazard that may cause fire or explosion. **PETROL (GASOLINE), LIQUID PROPANE AND DIESEL FUELS ARE FLAMMABLE.**

2.1.37



NEVER START THE NIFTYLIFT IF YOU SMELL PETROL (GASOLINE), LIQUID PROPANE OR DIESEL FUEL. THESE FUELS ARE HIGHLY FLAMMABLE

2.1.38

The operator shall implement means provided to protect against use by unauthorised persons.

2.1.39

Never remove anything that may affect the stability of the machine such as, but not limited to, batteries, covers, engines, tyres or ballast.

2.2 ENVIRONMENTAL LIMITATIONS

Unless specifically configured otherwise, the machine will have a short operational time in extreme temperatures such as freezers and cold storage, due to reduced battery performance. For electrical cables and components, the ambient temperature must be within the range -5°C to 60°C.

The machine is limited in high temperatures because of the cooling requirement for engines and hydraulic oil. Coolant temperatures must be within the range -37°C to 110°C (at 50% mixture of water to anti-freeze). Oil temperature must be within the range -23°C to 93°C.

The recommended operational ambient range for these machines is -5°C to +40°C. Please contact Niftylift Ltd for special considerations if the machine is required to operate outside these temperatures.

Extended operation in dusty environments is not recommended, as frequent cleaning will be necessary. All dust, dirt, salt encrustation, excess oil or grease should be removed. Deposits of paint or bitumen, particularly on legends or labels should be removed.

All standard Niftylift machines are rated for a wind speed of 12.5 m/s, which equates to 45kph / 28mph or force 6 on the Beaufort scale. No attempt should be made to operate a Niftylift in wind strengths above this limit and if the operator has any doubts over the wind speed he / she should cease operation immediately until it can be established that the wind speed has fallen to a safe level.



DO NOT USE THE NIFTYLIFT IN ELECTRICAL STORMS

2.3 NOISE AND VIBRATION

The airborne noise emission on the Height Rider range of machines does not exceed 79dB(A), measured at a perpendicular distance of 4m, under equivalent continuous A-weighted sound pressure test conditions. This was based on a Diesel powered machine, working on high throttle, and under load. All other models will exhibit significantly lower emissions than this figure, dependant on power option. In normal operation the Vibration level to which the operator is subjected will not exceed a weighted root mean square acceleration value of 2.5 m/s².

2.4 TEST REPORT

All Niftylift machine models are subjected to a comprehensive 'type test' which duplicates all combinations of safe working load (SWL), overload, windage, inertia and pull force to assess the various safe stability criteria. Self propelled machines are also subjected to kerb and braking tests at the SWL to satisfy additional 'worse case' stability requirements.

Each individual machine is then subjected to static overload tests on flat level ground with 150% of the SWL, exceeding the requirements of EN280 for power operated MEWPs. Self propelled machines are also tested at the maximum working angle **plus** 0.5° with a test load of 125% of the SWL. Finally, on all machines, a functional test is performed with 110% of SWL.

All safety devices are checked for correct operation, operating speeds are checked against benchmark figures and the dynamic functions ensure that all acceleration and deceleration forces are within acceptable limits. All noted defects are rectified and recorded before the machine is permitted to enter into service.

3 Preparation and Inspection

3.1 UNPACKING

Since the manufacturer has no direct control over the shipping or carriage of any Niftylift it is the responsibility of the dealer and/or owner and/or lessee to ensure the Niftylift has not been damaged in transit and a Pre-operational Report has been carried out by a qualified engineer before the aerial platform is put into service.

- 1) Remove all ropes, straps, and/or chains used to secure the aerial platform during transit.
- 2) Ensure any ramp, loading dock or forklift used is capable of supporting or lifting the aerial platform.
- 3) If the aerial platform is to be driven off, please ensure that the operator has read and fully understood this entire manual. Refer to the appropriate section for precise operating instructions.

Carry out the Pre-operational Report before placing machine in service.

3.2 PREPARATION FOR USE

Whilst every effort has been made at the Niftylift factory to ensure your machine arrives in a safe and operable condition it is necessary to carry out a systematic inspection prior to putting the aerial platform into service.



THIS IS NOT A REQUEST IT IS MANDATORY

To assist the user in this task you will find enclosed a Pre-operational Report, which must be filled out upon delivery/receipt of the machine.

Before the user carries out the Pre-operational Report he must have read and fully understood all the contents of the Operating, Safety and Maintenance Manual.



WARNING - DO NOT OPERATE A POTENTIALLY DEFECTIVE OR MALFUNCTIONING MACHINE. CORRECT AND REPAIR ANY DEFECTS BEFORE OPERATING YOUR NIFTYLIFT.

Operating & Safety Instructions

3.3 PRE-OPERATIONAL SAFETY CHECK SCHEDULES

Before use each day and at the beginning of each shift the aerial platform shall be given a visual inspection and functional test including, but not limited to, the following: It is recommended that these be performed at regular intervals as indicated on each checklist.

3.3.1 DAILY SAFETY CHECKS

- 1) Check that all labels (decals) are in place and legible.
- 2) Visually inspect the machine for damaged or loose components.
- 3) Check that all batteries are charged (Refer to Section 4.6 for further information).
Note; the diesel engine batteries are also used to power the emergency descent system.
- 4) Check the fuel level (if applicable).
- 5) Check that canopies/covers and guards are in place and secure.
- 6) Check that the boom rest switch is operable (if applicable).
- 7) Check that control levers are secure and operate freely.
- 8) Check that operating buttons and emergency stop buttons function correctly.
- 9) Check the operation of the emergency descent pump.
- 10) Visually inspect all hydraulic hoses and fittings for damage or leaks.
- 11) Check that the platform pivot pins and their tag bolts are secure.
- 12) Check that the tilt alarm is functioning correctly (On a slope of 5° or more the alarm should sound and drive should be disabled).
- 13) Check the operation of SiOPS (Refer to Section 4.3.5).
- 14) Check the operation of the cage weigh system (If fitted).

3.3.2 WEEKLY SAFETY CHECKS

- 1) Inspect tyres and wheels for damage and wear.
- 2) Check that the joystick manipulators are secure.
- 3) Check hydraulic oil level, ISO Grade 32 - Standard or Bio.
- 4) Check engine coolant level. **Caution**, the cooling system is pressurised, so allow engine to cool sufficiently before removing filler cap.
- 5) Inspect the engine air filter and clean or replace if necessary.
- 6) Inspect hose track for damage or missing parts.

3.3.3 MONTHLY SAFETY CHECKS

- 1) Check the engine oil level (if applicable).
- 2) Check wheel nuts are secured (torque 292 ft lbs / 396 Nm).
- 3) Check that the slew worm is secured and correctly in mesh. Clean and re-grease.
- 4) Check the track rod linkage.
- 5) Inspect brakes for operation and wear.
- 6) Inspect the engine fuel tank for damage or leaks.
- 7) Check telescopic boom wear pads and nylon studs (if applicable).

3.3.4 BI-ANNUAL SAFETY CHECKS

- 1) Every six months of operation, the wire ropes inside the telescopic boom should be inspected in line with national or local regulations, for example LOLER (6 month thorough inspection in the UK) or IPAF guidelines. Refer to instructions in the Wire Rope Inspection Manual (**M50752**).
Should any faults be found during inspection, information on repair and replacement can be found in the Wire Rope Inspection & Maintenance Manual (**M50490**).
- 2) Every six months perform a **thorough examination** in accordance with the 'Lifting Operation and Lifting Equipment Regulations' (LOLER) 1998, Regulation (9)(3)(a).

3.3.5 ANNUAL SAFETY CHECKS

- 1) Check that all pivot pins and their tag bolts are secure.
- 2) Inspect for any cracks or badly rusted areas on booms and chassis.
- 3) Change the hydraulic oil filters.
- 4) Check the bushes in the front wheel hubs for wear.
- 5) Check that slew ring bolts are secure (torque 199 ft lbs. 270 Nm).

Operating & Safety Instructions**3.4 PLACARD, DECALS & INSTALLATION (UK SPEC)**

ITEM	DESCRIPTION	NUMBER	QTY
1	Overload Warning	P18848	1
2	"If Tilt Alarm Sounds"	P14868	1
3	IPAF 'Are you trained?'	P22055	1
4	Clunk Click	P19961	1
5	"If E-Stop Disabled"	P14864	2
6	'Do not place objects on controls'	P21511	1
7	'Fitted with SiOPS'	P22820	2
8	Cage Controls	P27368	1
9	General Warning	P24900	1
10	Operating Instructions	P14892	2
11	Raise flyboom	P19442	1
12	Footswitch	P14884	1
13	Harness Point	P14883	3
14	Cage Gate Warning	P18335	1
15	SWL 280kg	(2-man) P24820	1
		(3-man) P24841	1
16	"Niftylift.com"	P14390	1
17	Cage tie-down warning	P21404	2
18	Hazard tape	N/A	N/A
19	Point Loading - 87.8kN	P25068	4
20	Tie Down Points	P14958	4
21	Travel Direction	P27048	2
22	Battery isolator	P18600	1
23	Battery Drain	P19850	1
24	Base lever - Cage level	P24823	1
25	Tank Pressure - Warning	P16365	1
26	Hydraulic Oil	P17226	1
	Low Temperature Bio Oil	P23622	1
27	4X4	P14697	2
28	Gearbox Disengage	P26280	2
29	Serial Plate - Blank	P15383	1
30	No Step	P14785	1
31	Diesel	P14414	1
32	Auxiliary descent	P24822	1
33	Control Buttons - Base	P25155	1
34	Emergency controls location	P21700	1
35	Daily Safety Check List	P14908	1
36	Hydraulic Levers – Base	P24821	1

***nifty* Height Rider/SP Series**
Operating & Safety Instructions

37	Auxiliary descent	P25067	1
38	'Green Machine' Large	P22804	1
39	Noise Warning dB	P17124	1
41	General crush hazard	P14782	8
46	'Nifty HR28 Hybrid'	P24781	1
	'Nifty HR28'	P25690	1
48	Tier 4 / EU Stage IIIB	P25407	1
49	Maintenance Free Batteries	P27750	2
50	110V Charge point	P26424	1
51	230V Charge Point	P26863	1
52	Power to cage - 110V	P26426	2
53	Power to cage - 230V	P26862	2
54	Power to cage - Universal	P24787	1
56	Light information (Diesel ONLY)	P27630	1
60	Power to cage - Generator	P28228	1
61	Wire Rope Inspection	P30580	1

nifty Height Rider/SP Series

Operating & Safety Instructions

nifty HR28 Series

D81856

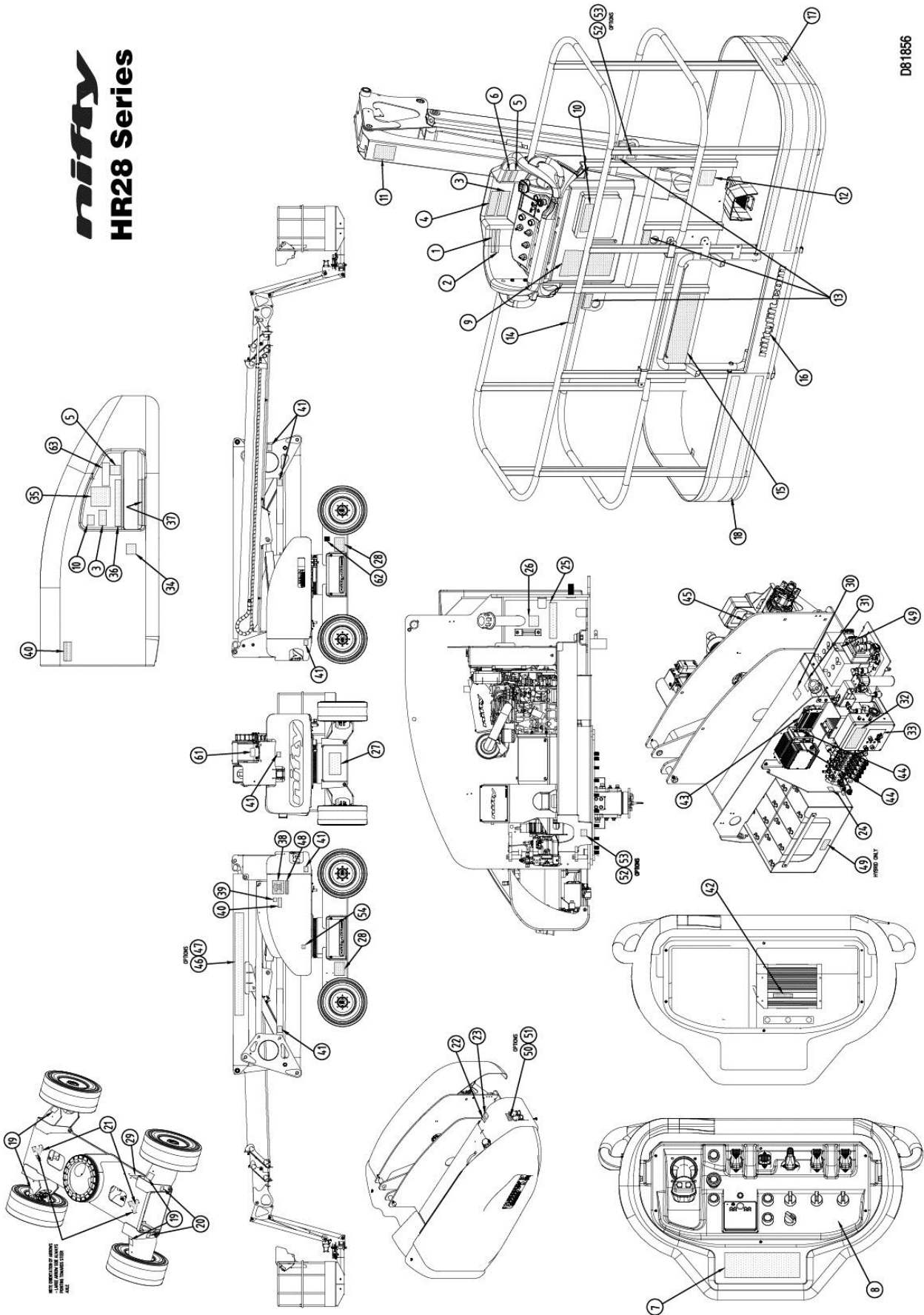

3.5 TORQUE REQUIREMENTS

BOLT QUALITY/SIZE	Tightening torque in lbs ft (Nm)					
	Plated			Unplated		
Grade	8.8	10.9	12.9	8.8	10.9	12.9
M 6	5 (7)	8 (10)	9 (12)	6 (8)	8 (11)	10 (13)
M 8	13 (17)	18 (25)	22 (29)	14 (19)	20 (27)	23 (32)
M 10	25 (34)	36 (49)	43 (58)	27 (37)	40 (54)	46 (63)
M 12	43 (58)	63 (85)	73 (99)	47 (63)	69 (93)	80 (108)
M 14	68 (93)	100 (135)	117 (158)	74 (101)	109 (148)	127 (172)
M 16	106 (143)	154 (209)	180 (245)	115 (156)	168 (228)	197 (267)
M 20	212 (288)	301 (408)	352 (477)	224 (304)	328 (445)	384 (521)
M24	362 (491)	515 (698)	602 (806)	383 (519)	561 (760)	656 (889)
WHEEL NUTS	292 ft lbs (396 Nm)					
WHEEL GEARBOX NUTS	99 ft lbs (135 Nm)					
SLEW RING BOLTS	199 ft lbs (270 Nm)					

This torque chart is based on the following assumptions:

- 1) Bolts to ISO 898-1 "Mechanical properties of fasteners made of carbon steel and alloy steel"
- 2) For "unplated" bolts, all grades:
 - Hex head bolts
 - Black oxide steel bolt with a rolled & oiled thread, no finish on steel nut
 - Prevailing torque includes Nylock (minimum prevailing torque figure assumed)
 - Medium Clearance holes to ISO 273
 - Bolt tightening condition = Yield factor of 75%
- 3) For "plated" bolts, all grades:
 - Hex head bolts
 - Zinc plated oiled (rolled or cut) steel external thread with no finish on steel internal thread
 - Prevailing torque includes Nylock (minimum prevailing torque figure assumed)
 - Medium Clearance holes to ISO 273
 - Bolt tightening condition = Yield factor of 75%

Figures quoted in **Nm** have been calculated in Nm and then rounded to the nearest whole number. Figures quoted in **lb-ft** have been calculated in Nm, converted using a factor of 0.737561 and then rounded.

4 Operation

4.1 CONTROL CIRCUIT COMPONENTS

4.1.1 GROUND CONTROLS

MASTER PROGRAMMEABLE LOGIC CONTROLLER (PLC): - Situated under the ground controls canopy, behind the Ground Controls Station is the Master PLC. The main purpose of the Master PLC is to process signals received from **all** areas of the control circuit on the machine and where appropriate output these to a series of smaller digital modules to operate the relevant machine functions.

Also, during machine operation, the Master PLC constantly receives signals from the Platform PLC (see Section 4.1.2) in order to monitor Safety Critical Functions. If for some reason any of these functions became inactive the Master PLC would immediately disable the machine.

TILT SENSOR: - Fitted to the superstructure behind the ground controls canopy, the tilt sensor is a solid-state sensor, which monitors the inclination of the machine chassis. When the platform is in use, i.e. Booms are raised, if the inclination exceeds the pre-set limit, it will disable all drive functions and sound the alarm. In order to recover the machine, boom operation is unaffected, allowing the operator to restore drive by lowering the booms into the stowed position. It is then possible to drive back onto level ground, fully restoring machine operation.

MULTI-TONE SOUNDER: - Situated inside the ground control station is a small electric sounder, which is used to provide an intermittent beep whenever the machine is in operation. Pushing a green "power control" button or depressing the foot switch in the platform will energise this sounder. This serves to warn personnel of the operation of the machine. In addition, it is this device which produces a ricochet type sound if a safety critical problem has been detected i.e. Tilt angle or Cage weight limits have been exceeded;

Cage Weigh: - If the electronic load cell detects an overload condition it will sound continuously in conjunction with the cage overload warning light.

Battery management: - when a low battery state is reached, the "pulsing" of the D.C. motors is mimicked by the sounder reinforcing the message to the operator to charge the machine. Note; if the sounder activates whilst using electric power only, it is advisable to start the engine enabling the operator continued use of the machine, whilst recharging the batteries.

HORN: - Located on the side of the ground control box is a horn, which is used as a manual alert, by pushing the "Horn" button on the Platform control panel.

BOOM SWITCH: - Mounted on the links knuckle and operated by the raising of link booms or upper boom, this switch controls both the operation of the Tilt Sensor, and the speed control function. With the booms in the stowed position, the Tilt Sensor is by-passed, allowing the machine to negotiate slopes in excess of the permissible working angle, without isolating the drive function. At the same time, High Speed drive (Depicted by a Hare Icon) is possible. When the booms are raised the Tilt Sensor is activated and only Slow Speed drive is permitted. These control functions are of primary importance to safety of the machine and operator; **under no circumstances should this control function be isolated or by-passed.**

TELESCOPIC BOOM SWITCH: - Mounted inside the telescopic boom, this switch controls the operation of the Tilt Sensor and Speed Control function as described in the previous paragraph.

SLEW SWITCH: - Mounted under the superstructure, this switch limits the drive speed to a preset low speed when the machine has been rotated from its stowed position.

4.1.2 PLATFORM

PLATFORM PROGRAMMEABLE LOGIC CONTROLLER (PLC): - Situated in the platform is the Platform Control Station. Behind the platform control panel is the Platform PLC. The purpose of the Platform PLC is to interpret signals received from the Platform Control Station and convert them to a digital signal, which is then output to the Master PLC for processing.

CAGE DISPLAY UNIT: - Mounted in the Platform Control Station, this gauge receives signals from the Master PLC to provide a warning indication to the operator for a range of functions. Refer to Section 4.3.2 for further details.

LOAD SENSING CONSOLE (SiOPS™): - This machine incorporates a load sensing console that senses if the operator has been pushed or has fallen against the console. If the load applied to the front of the console is greater than the pre-determined amount, the footswitch will be disabled to increase operator safety and reduce the possibility of sustained involuntary operation of the cage controls. For further information refer to Section 4.3.5.

4.1.3 CHASSIS

DIGITAL MODULE: - Situated inside the chassis, this unit is a local extension to the Master PLC and is used to control all hydraulic valves below the slew rotation gear.

MOTION CONTROL VALVE: - This valve comprises several individual components all directly involved in the hydraulic supply to the wheel drive motors. Included in these are the drive control valves which allow the operator to propel the machine forward or backward by using the Joystick (See Section 4.3.1).

In addition the Brake Release Valve (BRV) is also incorporated into this valve block. It is a solenoid operated valve, which controls the brake function on the machine. This valve must be energised to allow the machine to move. If no voltage is present, the wheel motors will not be able to develop drive torque, whilst at the same time, the parking brakes will remain engaged. The BRV will only operate when a green "Power Control" push-button is being used (or the Platform Foot-switch is depressed) in Drive mode. If the tilt sensor detects an excessive inclination whilst the booms are raised it is the BRV which is de-energised to isolate the machine.

4.1.4 POWER TRAY

AC MOTOR CONTROLLER: - Situated on the power tray, this unit converts DC power into AC to control the electric motor.

DIGITAL MODULE: - Situated on the power tray, this unit is a local extension to the Master PLC and is used to activate engine functions, and monitor readings such as water temperature and low oil pressure.

DIESEL ENGINE/ELECTRIC MOTOR: - A diesel engine assisted by an electric motor (when required) driving a load sensing swash pump. This arrangement allows proportional speed control of all appropriate functions.

Operating & Safety Instructions

BATTERY MANAGEMENT: - Battery condition is permanently monitored by the control circuit, such that when available power has decreased to 20% of full charge, the battery status circuit begins to "chop" the power to the hydraulic motors (If the machine is in Diesel mode at this point, it will automatically revert to a 'low power' state to protect the batteries). This function causes the drive system to stop & start alternately, signalling to the operator that re-charging is necessary. At the same time the sounder will begin to sound intermittently and the low battery warning light will illuminate, reinforcing the charge warning. At this point, sufficient power remains to allow driving to the nearest power point. Should the operator ignore the on-set of the discharge warning, the "chopping" will continue until the machine is rendered inoperative. Immediate charging will then be required.

Note; During normal machine usage with the engine running, the batteries are on continuous recharge. The exception to this is when the control system decides that additional electric power is required in order to maintain drive/function speed. If the operator is using electric power only and a low battery warning has activated, it is advisable to start the engine, enabling continued use of the machine, whilst at the same time recharging the batteries.

BATTERY ISOLATOR: - The battery-disconnect handles are located under the links, adjacent to the service canopy. In order to isolate the machine control and power circuits from the batteries it is necessary to pull the release handles, disconnecting the supply to the entire control system. Under **normal** operation, the machine **key switch** should be used to **isolate** the machine, with the battery isolator handle only being required for emergencies, in the event of a short circuit, or during routine maintenance.

BOOMS ENABLE VALVE: - Situated behind the Ground Control Station, this valve contains the ON/OFF solenoid and PRV for the boom controls.

4.1.5 DUTY SELECTOR: - On multiple power option machines, the machine will default to electric power unless the diesel engine has been started.

4.1.6 FUSES & TRIP SWITCHES: -

Power Tray

- 35A** Circuit breaker inside ABS box
- 2 x 10A** Circuit breaker inside ABS box

Chassis

- 2A** Circuit breaker inside box

Ground Control Station

- 1 x 325A** Fuse
- 1 x 225A** Fuse
- 1 x 125A** Fuse (Hybrid only)
- 4 x 15A** blade fuses inside Ground Control Box
- 1 x 2A** blade fuse inside Ground Control Box
- 1 x 15A** Circuit breaker

Platform Control Station

- 2 x 15A** blade fuses behind Control Panel
- 2 x 2A** blade fuses behind Control Panel

4.2 GROUND CONTROL OPERATION

4.2.1 GROUND CONTROL FUNCTIONS

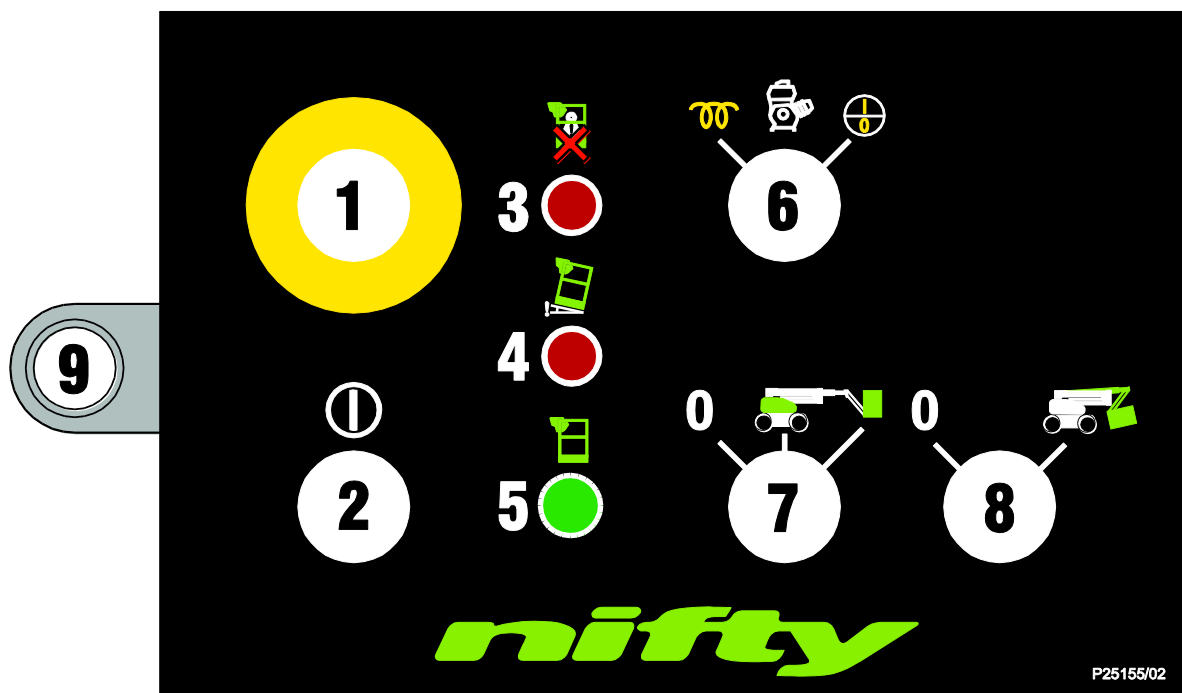

1 Emergency Stop	Push to Stop Operation	Twist to Enable Operation
2 Green Power Button	Push and hold for Power	Release to Cease operation
3 Red Lamp	Indicates Safe Working Load limit or Maximum Tilt Angle exceeded. Safely remove any unnecessary items from the platform or lower booms to stowed position and drive on to level ground to restore machine functions.	
4 Red Lamp	Indicates maximum Cage Level Angle exceeded. Press Aux Powered Descent button (9) whilst operating the platform levelling lever to relevel the cage in order to restore cage functions.	
5 Green Lamp	Indicates machine is switched on. Lamp will extinguish during a safety critical condition when red lamp (3 or 4) is flashing.	
6 Engine Glow & Start/Stop	Anti-clockwise for Glow , Clockwise to Start/Stop engine	
7 Base/Platform Selector	Clockwise for Platform, Centre for Base, 0 for all power off	
8 Transport Selector	Turn Clockwise to allow cage to be 'tucked in' for transportation purposes.	
9 Auxiliary Powered Descent	Push and hold to enable boom functions in the event of normal operation loss. (i.e. Fuel tank empty)	

Operating & Safety Instructions

Base Levers



1	Operates Platform Levelling	Backward for Down	Forward for Up
2	Operates the Flyboom	Up for Up	Down for Down
3	Operates Telescoping	Up for Out	Down for In
4	Operates the Link Booms	Up for Up	Down for Down
5	Operates the Upper Boom	Up for Up	Down for Down
6	Operates Swing	Up for Right	Down for Left
7	Operates Front Wheel Steer	Forward for Right	Backward for Left

4.2.2 OPERATION

ALWAYS ALLOW THE ENGINE TO WARM UP BEFORE OPERATING



ALL MODELS

- 1) Ensure all red emergency stops are out.
- 2) Turn key switch at ground control station to **Ground** (Single turn clockwise).
- 3) For **Battery** powered operation, go to step 9).
- 4) For **Diesel** powered operation, go to step 5) or step 7).

HYBRID

- 5) **COLD ENGINE:** - turn the **Diesel Glow/Start** selector to the **Glow** position (anti-clockwise). This engages the glow plug pre-heat system. Hold for 5-10 seconds then turn the key to the **Start** position (fully clockwise) and the engine will fire.
- 6) **WARM ENGINE:** - turn the **Diesel Glow/Start** selector to the **Start** position (clockwise) and the engine will fire.

Note: Unless the diesel engine is running, the HR28 Hybrid will automatically default to the electrical power source (battery).

DIESEL

- 7) **COLD ENGINE:** - turn the **Diesel Glow/Start** selector to the **Glow** position (anti-clockwise). This engages the glow plug pre-heat system. Hold for 5-10 seconds then turn the key to the **Start** position (fully clockwise) and the engine will fire. However, there is a time delay dependant on fuel temperature (Refer to table below). For example, if the fuel temperature is -15°C there will be a delay of 2 seconds after turning the key, before it starts cranking. After the engine has started it will only operate at idle speed for a further 35 seconds.

Fuel Temperature (°C)	Crank delay (seconds)	Idle delay (seconds)
-25	2	60
-20	2	50
-15	2	35
-10	2	20
-5	0	15
0	0	12
10	0	8
20	0	5
30	0	5

- 8) **WARM ENGINE:** - turn the **Diesel Glow/Start** selector to the **Start** position (clockwise) and the engine will fire.

ALL MODELS

- 9) Push and hold green power button on the base control panel.
- 10) Select one or more functions and operate the appropriate hydraulic levers in full accordance with manufacturers operating and safety manual. (Refer to Section 4.2.1)
- Note:** Move lever until resistance is felt, then push/pull harder to activate function.
- 11) To return control to the platform, turn base control key-switch to the **Platform** position (fully clockwise).
- 12) When not in use, return machine to stowed position. **Note:** Fully lower the Link booms first (Lever 4) followed by the Upper boom (Lever 5) for smooth operation. Turn the **Base/Platform** selector anti-clockwise to the **Off** position, remove key and chock wheels.

EMERGENCY PROCEDURES

- 1) Push in red emergency stop to shut down all functions.
- 2) In the event that the controls fail or the operator becomes incapacitated the booms can be operated by using the **auxiliary emergency pump** which is located under the canopy adjacent to the base controls as follows:
 - a) Operate appropriate control lever as required.
 - b) Press and **hold** the white button adjacent to the base controls. (Refer to Section 4.2.1)

Note: if lowering the telescopic boom, it will be necessary to also operate the manual levelling lever (Refer to Section 4.2.1) to ensure the platform remains level. It is recommended to halt boom lowering, level platform then commence with descent.
Repeat this in stages as the boom is lowered.
 - c) Release white button to halt machine movement.
 - d) Release control lever.

4.3 PLATFORM CONTROL OPERATION

4.3.1 PLATFORM CONTROL FUNCTIONS

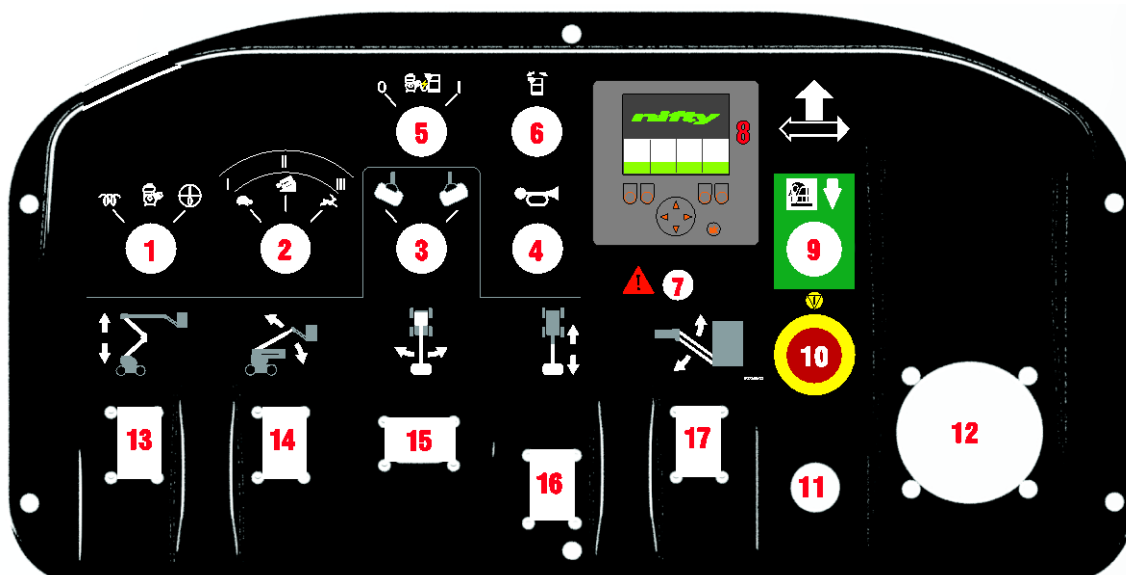

1 Engine Glow/Start/Stop	Anti-clockwise hold for Glow	Clockwise to Start/Stop engine
2 Speed Selector <i>Booms Drive</i>	Left - Speed I Tortoise	Centre - Speed II Off-road Right - Speed III Hare
3 Platform rotation	RH arrow for Anti-clockwise	LH arrow for Clockwise
4 Horn	Press & hold to Sound	
5 Power to cage	Start engine then Turn clockwise to activate	
6 Auto Cage Levelling	Flashes when cage angle has exceeded comfortable preset limit. Push button to re-level cage and restore machine functions.	
7 Safety Warning Lamp	Indicates Safety Critical Problem (Refer to Digital Gauge immediately)	
8 Digital Gauge	See Section 4.3.2	
9 Auxiliary Powered Descent	Push and hold to enable boom functions in the event of normal operation loss. (i.e. Fuel tank empty)	
10 Emergency Stop	Push to Stop Operation	Turn clockwise to Release
11 Green Power Button	Push and hold to activate machine	
12 Joystick	Grip the joystick and hold the trigger switch at the front. Machine movement is achieved by slowly moving the joystick away from the neutral position in the required direction. Steer by using the thumb rocker switch located on top of the joystick.	
* 13 Operates Link Booms	Up for Up	Down for Down
* 14 Operates Upper Boom	Up for Up	Down for Down
* 15 Operates Swing	Left for Left	Right for Right
* 16 Operates Telescoping	Up for Tele-In	Down for Tele-Out
* 17 Operates Flyboom	Up for Up	Down for Down

*** More than one function can be operated at the same time**

Operating & Safety Instructions

4.3.2 CAGE DISPLAY UNIT

Situated on the Cage Control Panel, this gauge provides a warning indication for a range of functions. For further information refer to Section 4.3.3 'Information Icons' on Page 29. During machine operation the gauge displays current fuel or battery level, cage load status, current boom/drive speed setting and usage hours.

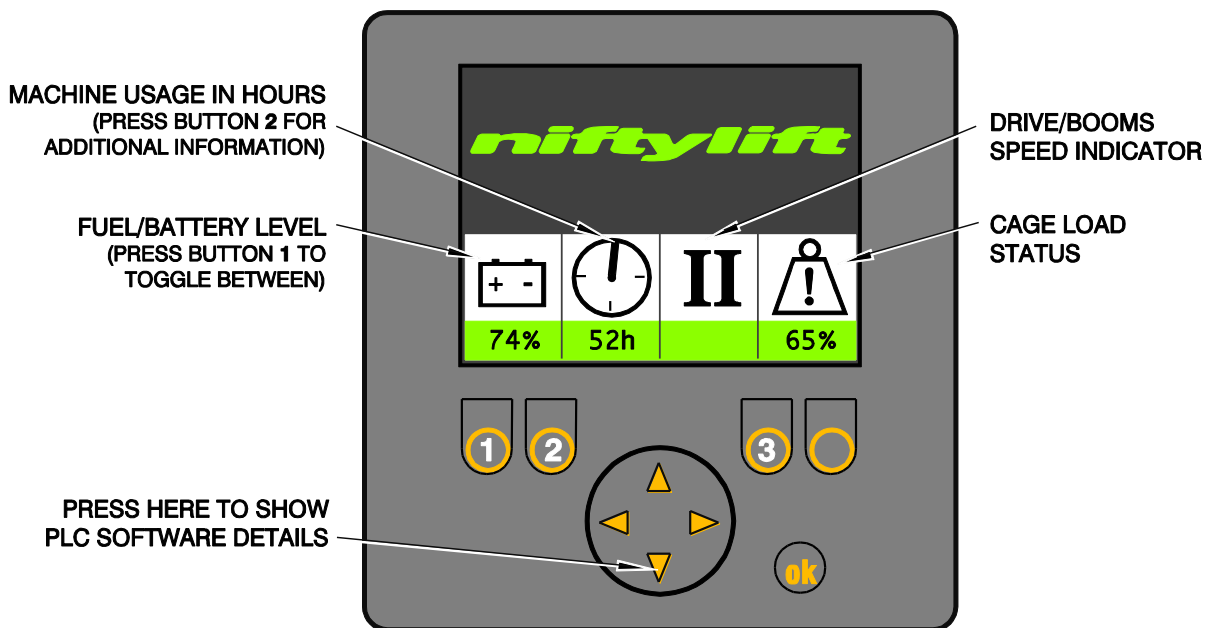

In addition, if the control system detects a malfunction elsewhere on the machine, an error code will be displayed (see below). For further information refer to **Appendix A**.

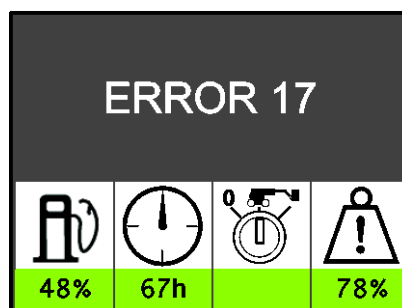

4.3.3 INFORMATION ICONS

Safety Critical



Safe Working Load exceeded:- The alarm sounds and the display alternates between the images shown here. The Maximum SWL (280kg/620lbs) has been exceeded. Immediately remove any unnecessary items from the platform **in a safe manner** to restore machine functions.



Alternatively, the platform may have come into contact with a fixed object, see Section 5.3 for recovery procedure.

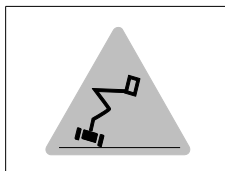

MAX tilt angle exceeded:- The alarm sounds and the display shows this image. Lower booms into stowed position and drive onto level ground to fully restore machine operation.

Note: If a **Safety Critical** condition (red flashing triangle) has been detected, the safety warning lamp on the Platform Control Panel and Base Control Panel will also illuminate.

Advisory



Boom Function Speed: Determined by the Speed Selector switch on the Cage Control Panel (Refer to Page 27).



Drive Speed: Determined by the Speed Selector switch on the Platform Control Panel (Refer to Page 27). Digital display reverts to these icons once the joystick trigger is activated.

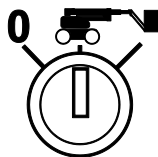

Ground Controls: To enable platform controls, selector switch located on ground controls must be turned clockwise. (Refer to Section 4.2.1, Item 7)



6%

Fuel Level Low: Flashing fuel pump icon indicates fuel tank is <10% full.



Engine Running: Flashing arrow adjacent to the engine icon indicates diesel engine is running.

nifty Height Rider/SP Series

Operating & Safety Instructions

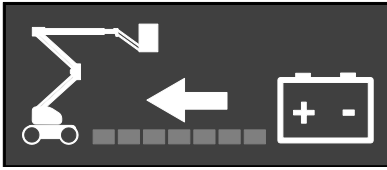

Battery Power

Machine is in operation using battery power.

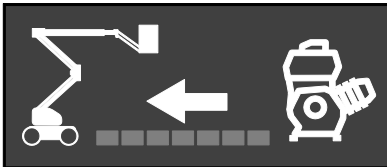

Diesel Engine Power

Machine is in operation using engine power.

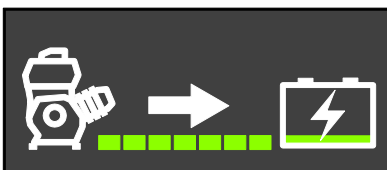

Diesel Re-Gen (Hybrid mode)

Machine is in operation using engine power and recharging the batteries.

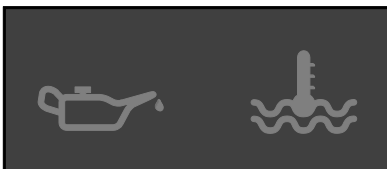

Oil Pressure/Water Temperature

Low engine oil pressure or high water temperature. Top-up may be necessary. Refer to Niftylift Service Manual for further information.

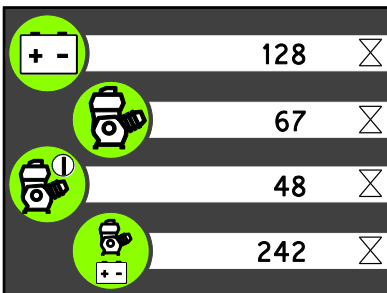

Machine Usage Hours



To access this screen, press button **2** (refer to Section 4.3.2).

Battery, Diesel Engine, Green Button and Hybrid usage hours are displayed.

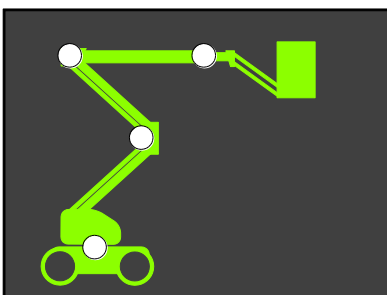

Limit Switch Status



To access this screen, press button **3** (refer to Section 4.3.2).

A **RED** circle indicates machine is not fully stowed. If the machine is in the stowed position all switches will be displayed as **WHITE**.

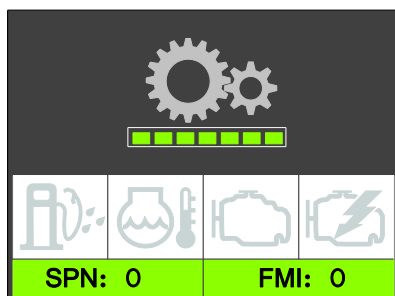

Diesel engine diagnostic page (HR28D only)

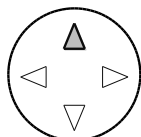

To access this screen, press **UP** arrow.
(Refer to Section 4.3.2)

It also appears when starting the engine during crank delay
(Refer to Section 4.2.2, Step 7).



Water in fuel

Refer to service manual for instructions on how to drain water from the diesel fuel filter.



Protection Lamp

Indicates a non electronic problem, e.g. Coolant temperature has exceeded defined range.



Amber Warning

Engine ECU has detected a malfunction. Refer to Niftylift Service Manual, Section 6.3.3 for SPN and FMI fault codes.



Red STOP

Indicates severe condition. Turn off engine **immediately**. Refer to Niftylift Service Manual, Section 6.3.3 for SPN and FMI fault codes.

Operating & Safety Instructions

4.3.4 OPERATION



NEVER START THE NIFTYLIFT IF YOU SMELL PETROL (GASOLINE), LIQUID PROPANE OR DIESEL. THESE FUELS ARE FLAMMABLE.

BEFORE OPERATING THE NIFTYLIFT ENSURE THAT EACH OPERATOR HAS READ AND FULLY UNDERSTOOD THE OPERATING MANUAL. FAILURE TO DO SO MAY RESULT IN DEATH OR SERIOUS INJURY.

ALL MODELS

- 1) Ensure all red emergency stops are out.
- 2) Turn key switch at ground control station to **Platform** (fully clockwise).
- 3) For **Battery** powered operation, go to step 9).
- 4) For **Diesel** powered operation, go to step 5) or step 7).

HYBRID

- 5) **COLD ENGINE:** - turn the **Diesel Glow/Start** selector to the **Glow** position (anti-clockwise). This engages the glow plug pre-heat system. Hold for 5-10 seconds then turn the key to the **Start** position (fully clockwise) and the engine will fire.
- 6) **WARM ENGINE:** - turn the **Diesel Glow/Start** selector to the **Start** position (clockwise) and the engine will fire.

Note: Unless the diesel engine is running, the HR28 Hybrid will automatically default to the electrical power source (battery).

DIESEL

- 7) **COLD ENGINE:** - turn the **Diesel Glow/Start** selector to the **Glow** position (anti-clockwise). This engages the glow plug pre-heat system. Hold for 5-10 seconds then turn the key to the **Start** position (fully clockwise) and the engine will fire. However, there is a time delay dependant on fuel temperature (Refer to Section 4.2.2, Step 7).
- 8) **WARM ENGINE:** - turn the **Diesel Glow/Start** selector to the **Start** position (clockwise) and the engine will fire.

ALL MODELS

- 9) Set the **speed selector** control as required. Speed **I** gives **minimum** function control speed and Speed **III** allows **maximum** function control speed.
- 10) Depress the footswitch or push and hold green power button on the platform control panel.
- 11) Select one or more functions and operate the appropriate proportional paddles (levers) in full accordance with manufacturers operating and safety manual.
- 12) To return control to the base, turn the base control key-switch to the **Base** position (centre).

- 13) When not in use, return machine to stowed position. **Note:** Fully lower the Link booms first (Lever 4) followed by the Upper boom (Lever 5) for smooth operation. Turn the **Base/Platform** selector anti-clockwise to the **Off** position, remove key and chock wheels.



ALWAYS ENSURE THE AERIAL PLATFORM IS ON A FIRM LEVEL SURFACE AND THE AREA IS FREE OF ANY OVERHEAD OBSTRUCTIONS.

ENGAGING THE RED EMERGENCY STOP BUTTON WILL SHUT DOWN THE ENGINE, AND THE ELECTRIC CIRCUIT PREVENTING OPERATION OF ANY FUNCTION.

4.3.5 SiOPS™ - LOAD SENSING CONSOLE



WHEN OPERATING THIS MACHINE THE USER MUST BE AWARE OF ANY OVERHEAD OBSTRUCTIONS.

This machine incorporates a load sensing cage console that senses if the operator has been pushed or has fallen against the console. If the load applied to the front of the console is greater than the pre-determined amount, the footswitch will be disabled to increase operator safety and reduce the possibility of sustained involuntary operation of the cage controls.

Note: The green button will illuminate once the footswitch has been disabled, but continues to be available for use at all times. This allows the operator to use the cage control functions and manoeuvre the machine to a safe position.

To reset the footswitch:

- 1) Release the load from the front of the console.
- 2) Ensure cage controls are in the neutral position and clear of objects.
- 3) Raise foot clear of footswitch then lower foot onto footswitch.
- 4) Footswitch is now active and full control has been restored.

Note: If SiOPS™ has been activated and the footswitch is not reset within **15 seconds**, then the blue warning beacon will flash (if fitted, located on underside of the cage) and a warning announcement will sound until the footswitch is reset as described previously.

Operating & Safety Instructions

4.4 DRIVING CONTROLS



DO NOT OPERATE THE NIFTYLIFT WHILST ELEVATED UNLESS ON A FIRM, LEVEL SURFACE FREE FROM ANY POSSIBLE OBSTRUCTIONS OR HAZARDS BOTH AT GROUND LEVEL AND OVERHEAD.

- 1) Check proposed route for possible hazards, obstructions and personnel.
- 2) Depress footswitch located on platform floor.
- 3) Set the **speed selector** switch on the platform control station as required.

Low Drive (Tortoise) - gives low speed and low engine revs.

High Drive (Hare) - gives high speed and high engine revs.

Off-road (High Gradeability) - gives low speed, high engine revs and high gradeability.

Note; **High Drive** Speed is only available when the booms are stowed and in **alignment** with the chassis i.e. at 0° or 180° rotation. **The HR28 will default to Low Drive speed whenever the booms are elevated.**

If the machine is driven on slopes exceeding 10° it automatically reverts to **Off-road** speed (High Gradeability). To return the machine to Low or High Drive, drive on to level ground (<10°) then release and reactivate the joystick or footswitch.

- 4) Select drive joystick from the platform control panel.

Push forward for **FORWARD DRIVE**

Pull backwards for **REVERSE DRIVE**

Steering is controlled by the rocker-switch button on the top of the joystick

Left for **STEER LEFT**

Right for **STEER RIGHT**

The driving horn is activated by a button on the platform controls (Refer to Section 4.3.1).

All control levers give a fully proportional response therefore the more the lever is moved away from the centre **Off** position the faster the function will become.

Maximum drive speed is only attainable when all booms are fully stowed and the **speed** selector is in the **High Drive (Hare)** position (clockwise).

When driving with the booms fully stowed, the Tilt Sensor is bypassed to allow the Niftylift to be driven in areas where the slope exceeds the pre-set working limit. In normal operation the drive is therefore unaffected when driven onto a slope in excess of this limit, until the booms are raised, whereupon the drive would be disabled and the tilt alarm sounds continuously.



ALL NIFTYLIFTS ARE FITTED WITH A TILT ALARM - PRE-SET IN THE FACTORY. ONCE ENERGISED, THE NIFTYLIFT WILL LOSE ALL POWER TO DRIVE FUNCTIONS AND A LOUD AUDIBLE ALARM WILL BE ACTIVATED.

TO DE-ACTIVATE, LOWER THE BOOMS FULLY TO THEIR STOWED POSITION AND RE-POSITION BASE ON FIRM, LEVEL GROUND.

IF ALARM SOUNDS - DESCEND IMMEDIATELY AND RE-LEVEL MACHINE BASE.

4.5 CAGE WEIGH SYSTEM

4.5.1 LOAD CELL VERSION

The Niftylift HR28 is fitted with an electronic load cell. This load cell is a moment-independent, redundant design. This means that independent of the load position inside the machine cage, the actual load is measured and if pre-configured limit values are exceeded, warnings will be activated. "Redundant design" means that the load cell design incorporates dual channels that monitor each other. The design of the unit meets the requirements of both EN280 and EN954-1 class III.

4.5.2 CALIBRATION, INSPECTION AND MAINTENANCE

Calibration, maintenance and repair of the Niftylift HR28 cage load cell requires specialist knowledge and equipment. **For this reason, no part of the Niftylift HR28 cage-weigh system can be adjusted, repaired, or inspected by the operator.**

All enquiries relating to calibration, inspection or maintenance should be directed to Niftylift or one of their approved dealers. Contact details are listed in Section 1.3.

Operating & Safety Instructions

4.6 BATTERIES AND CHARGING

- 1) Recharge batteries at the end of every working day or shift.
(**Note:** To recharge batteries fully from 20% charged takes approx. 12 Hours, this consists of 8 hours bulk charging plus 4 hours equalisation. The recharging time can be reduced to approx 4-6 hours by running the engine whilst charging).
- 2) Plug charger into suitable power supply, either 240 volts or 110 volts AC (see **Charging Limitations**). (Note: If using 240V, use of a suitably rated Earth Leakage Circuit Breaker (ELCB) or Residual Current Device (RCD) at the point of supply is highly recommended.) The charger will conduct a self-test at this point indicated by flashing all lamps in sequence.
- 3) Take note of the indicators provided:

Amber AC lamp: *Static* - Batteries are charging.
Flashing – Low AC voltage. Check source.

Amber CHARGE lamp: *Static* - Batteries are charging and between 80% & 100% capacity.

Green FINISH lamp: *Static* - the batteries are fully charged.
Flashing – Finishing phase.

Red lamp flashing: Fault (see 'Charging Limitations').

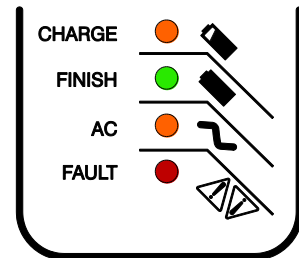

- 4) The charger will automatically switch off once the batteries are fully charged. It is recommended to reconnect the charger to a suitable power supply when the machine is not in use to maintain good battery condition. Charger will monitor and maintain correct battery charge level.



UNDER NO CIRCUMSTANCES SHOULD A MACHINE BE LEFT FULLY DISCHARGED AS SEVERE BATTERY DAMAGE CAN OCCUR IN A RELATIVELY SHORT TIME.

- 5) The machine boom functions can be used whilst on charge. **Do not drive** machine to avoid damage to cables etc. To disconnect charger, firstly switch off the power supply. Ensure LED's are **off** before disconnecting the charger from the power supply.

Notes:

- 1) If the charger is reconnected to the power supply shortly after it has gone through its full charging cycle, the charger will show the Amber AC lamp, immediately followed by the Amber Charge lamp. The charger would then go through its complete cycle again at an accelerated rate, depending on the time difference between connection, reconnection, and level of battery charge.
- 2) Some machines are fitted with a Battery Management System, which permanently monitors the condition of the batteries. When the batteries become discharged to 20% of their capacity the management system will begin to "shut down" the hydraulic power packs. This causes the drive/boom operating system to alternately stop and start, signalling to the operator that re-charging is necessary. However, there is sufficient power remaining to enable the operator to drive slowly to the nearest charging point.

- 3) During normal machine usage with the engine running, the batteries are on continuous recharge, except when the control system decides that additional electric power is required in order to maintain drive/function speed.
- 4) The machine has two charging units (Master and Slave). Both units will activate initially, the Slave unit will switch off at approximately 80% capacity then the Master unit will complete the charging cycle.

Should the operator ignore the onset of the battery discharge warning the "shut down" of the motors will continue, until the machine is rendered in-operative. **Immediate charging will then be required.**

CHARGING LIMITATIONS

The capacity of the 110V supply must be capable of 3.5kVA (32A current); hence a small hand-tool transformer must **not** be used with the battery charger.

Note; charger output will fall if air temperature is below 0°C or above 50°C.

The charger may become hot during charging. Use hand protection to safely handle the charger.

Fault Conditions

If a fault occurs, count number of flashes between pauses and refer to table:

Red LED status	Cause	Solution
One flash	Battery High Voltage	Check battery size and condition. This fault will automatically clear once the condition has been corrected.
Two flashes	Battery Low Voltage	Check battery size and condition. This fault will automatically clear once the condition has been corrected.
Three flashes	Charger Timeout. Caused by battery pack not reaching required voltage. Charger output reduced due to high ambient temperature.	Check connections. Operate charger at a lower ambient temperature. Reset charger (interrupt AC power for 15 seconds)
Four flashes	Check Battery(ies); battery could not be trickle charged up to minimum voltage.	Check for shorted or damaged cells Reset charger (interrupt AC power for 15 seconds)
Five flashes	High temperature. Charger shut down due to high internal temperature.	Ensure sufficient cooling airflow and reset charger (interrupt AC power for 15 seconds)
Six flashes	Charger Internal Fault	Reset charger (interrupt AC power for 15 seconds). Return to service department if fault persists.

Operating & Safety Instructions

Attention should also be given to the use of extension cables as power leads. **Excessive cable lengths** from the supply point to the battery charger will result in **significant voltage drop**, leading to a reduction in the chargers efficiency. In addition, inadequate sized cable cores will have a limiting effect on its current carrying capacity, which will again lead to a reduction in the chargers efficiency. Both of these can result in **over-heating** of the cable with an increased risk of fire, short circuits, or damage to the components themselves.

The charger requires a minimum battery voltage of 1.5 volts per battery (overall for two batteries 3 volts, for 4 batteries 6 volts for 8 batteries 12 volts and 18V for 72V). If the voltage is below these values then the charger will not function (Charger will not detect batteries to begin charge.) If the batteries have fallen to such a poor state they will have to be removed from the machine and charged individually with an independent charger until the optimum voltage has been reached. This is best performed at very low currents to 'recover' the batteries if sulphation has already started i.e. a 'trickle' charger. This can take several hours, possibly days. Careful monitoring of the rise of battery voltage will indicate when recovery has been achieved.

TOPPING UP

The batteries installed on this machine are **Maintenance Free**, therefore **DO NOT REFILL** with de-ionised water. Irreparable damage will occur.

4.7 TRANSPORTING, TOWING, CRANEAGE, STORAGE, AND SETTING TO WORK

4.7.1 TRANSPORTING

If a work platform is to be moved over a longer distance, whether the machine is trailer mounted, vehicle mounted, self propelled or tracked, the following procedure should be read before restraints are attached to the machine. Cross loading is most frequently the cause of problems, as the method of loading is no longer in sight of our own personnel. The recommendations made herein should be passed on to subsequent carriers, such that the entire journey is carried out without incident.

- Always ensure the truck or trailer you are loading or towing the Niftylift with can carry it legally.
- If loading by crane the use of shackles and an adequately rated spreader beam, with four leg slings, is **MANDATORY**.
- When loading or un-loading from the side of the vehicle, the use of the forklift pockets to retain one of the forks is recommended. (If fitted). Spread the forks to their widest capacity, with due regard to the components fitted to the machine. Never forklift or crane an entire machine under the booms, always lift beneath the spine or under the ends of the axle mountings in the case of a self-propelled unit. Ensure forklift is adequately rated for the load to be carried.
- Once positioned on the transport carrier ratchet straps should be used to secure the machine. The machine should be positioned to allow easy access around the machine in transit, and to ensure that 'creepage' during transport does not permit the machine to come into contact with other goods being shipped, or the container itself. Some movement of the machine structure might occur during transit, which could lead to fretting or other damage.
- If the machine is equipped with a transit device such as a boom clamp etc, this should be securely applied.
- Strap booms carefully to constrain them from sideways movement. When using straps or chains, adequate packing should be applied to stop any damage to the structure and paintwork. Due regard of the movement of the straps or chains must be taken into account.
- Where a machine has designated points for strapping, lifting or forking, these can be used for tie-down duty. When they are absent, the major structure of the platform can be used, giving due consideration to the design and function of the area chosen. Where possible, use the spine of the machine or axle mounts over which to apply the holding down forces. Using a single plate, such as an outrigger or stabiliser support plate might be unsuitable. If the component was clearly not designed to accommodate a side load, one should not be applied.
- Under no circumstances should straps or chains be applied over booms or through the cage support structure or the cage itself. The relative strength of the carrying structure is not conducive to the massive forces capable of being applied through ratchet chains or slings. Severe damage to the steelwork can be caused, as well as deformation to sensitive mechanisms such as cage weigh assemblies, which would render them useless. Such catastrophic damage to say, an electronic load cell would require the component to be replaced before the machine would function.

Operating & Safety Instructions

4.7.2 TOWING

If the Niftylift needs to be towed in case of an emergency, it will be necessary to chock the wheels before starting any of the following actions.

GEARBOX DISENGAGEMENT

In order to safely tow the HR28, the drive mechanism will need to be bypassed. The drive gearboxes located on the front and rear wheel hubs must be disengaged as follows;

- 1) Place a suitable container under the drive hub to capture oil spillage.
- 2) Using an Allen key, remove the central plug.
- 3) Using a suitable hydraulic jack, lift the machine until the relevant wheel is clear of the ground.
- 4) Screw an M8 bolt into the central pinion and carefully pull the pinion out of the gearbox. Slight movement of the wheel may be required whilst carrying out this procedure.
- 5) Re-install the central plug.
- 6) To re-engage the gearbox, remove central plug and refit central pinion ensuring wheel is jacked up clear of the ground.
- 7) Re-install central plug.
- 8) Top up gearbox oil as required, ensure drain plugs are horizontal (see diagram).

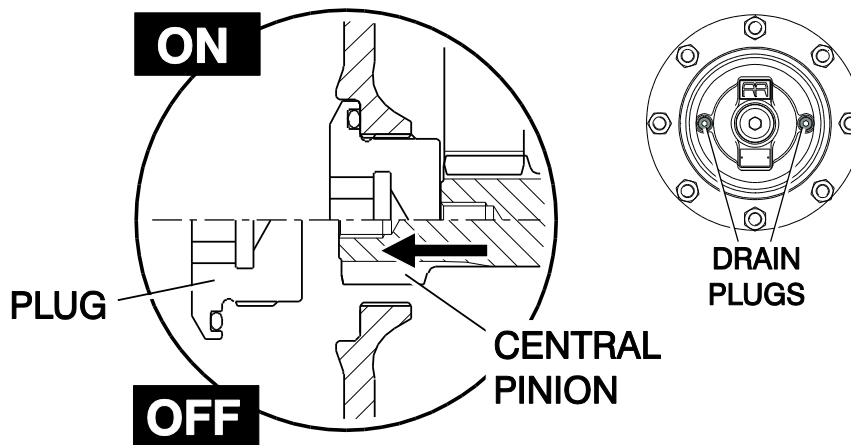

4.7.3 CRANEAGE

- 1) Observe all of the limitations relating to straps and chains stated above under 'Transporting'. (4.7.1)
- 2) When utilising the designated lifting points never apply a 'snatch' load, i.e. lift slowly to take up the load before raising. Similarly, do not drop machine when positioning after lifting.
- 3) If the machine is to be lifted by crane, use the designated lifting points and observe the recommendations regarding spreader beams. Individual drawings are available for each machine type, on request (See below).

D81742

HR28

4.7.4 STORAGE

If being stored for any length of time without use, then the machine should be thoroughly inspected for the following:-

- 1) Grease all bearings /slides, worm drives, etc.
- 2) If machine is to be left on an incline, chock wheels to prevent creep.
- 3) If machine is to be left outside or in a hostile environment, cover with suitable weatherproof media to prevent deterioration.

4.7.5 SETTING TO WORK

Before use each day and at the beginning of each shift the machine shall be given a visual and functional test including, but not limited to, the following

- 1) Check all lubrication points for adequate application of grease, oil etc.
- 2) Inspect all threads for ease of operation - especially descent valves, brake release valve etc.
- 3) Check level and quantity of oil. Remove any contaminants - water, etc.
- 4) Check batteries for electrolyte and state of charge.
- 5) Check electrics for damage and insulation.
- 6) Using ground controls, cycle machine over complete envelope in accordance with the Operating Instructions. Cure any defects.
- 7) Ensure that all safety devices and controls operate in accordance with the instructions.
- 8) If necessary, perform a load test to establish the machine stability before putting the machine to work.
- 9) On completion of an extended period of road transport, the machine might need additional inspection to identify any transit degradation, which could render the machine unsafe. Perform a P.D.I. inspection on the unit before it enters service. Record any faults found and rectify them immediately.
- 10) If left un-attended for an extended period, it is likely that the hydraulic cage levelling will become un-pressurised. Normal operation is then lost, with a noticeable delay in the forwards or backwards motion as the booms move. To restore normal function, operate the cage-levelling function at the Ground Control Station, the cage needs to be fully levelled forwards and backwards. When the system has been charged in both directions, the cage levelling function should be restored. Repeat the procedure as described above until the movements are smooth and un-interrupted. If in doubt, contact our Service Department for further advice.

Niftylift Limited is not liable for any third party damage caused during transport. Careful attention to correct procedures will prevent many of the small snags that can happen in transit. Re-work is both expensive and time consuming. A defective machine arriving at the place of work is a poor advertisement for our product, the company's reputation and those of our dealers and clients. The responsibility for safe and damage-free transport rests with the haulier or his representatives.

5 Emergency Controls

5.1 GENERAL

CHECKING THE OPERATION OF THE EMERGENCY CONTROLS EVERY DAY AND/OR BEFORE EACH SHIFT IS AN ESSENTIAL PART OF THE OPERATOR'S DUTIES



The operator and all ground personnel must be thoroughly familiar with the location and operation of the emergency controls.

5.2 IN THE EVENT OF AN INCAPACITATED OPERATOR

Turn the key switch at the ground control station to **ground** (central position).
Manoeuvre the machine using the ground controls as described previously in Section 4.2.

5.3 IN THE EVENT OF MACHINE FAILURE

If all machine power is lost, the **auxiliary emergency pump** can be used to provide the hydraulic power to manoeuvre the machine (Refer to Section 4.2.2). If initial movement of the machine allows the master alarm to reset, normal controls will be available. This is then the fastest method of lowering the platform to the ground.

Note: If the machine is fitted with a cage overload system, and the cage comes into contact with a fixed object whilst operating at height, this would be detected as an overload condition. All power to the machine controls would be lost, requiring the machine to be recovered using the **auxiliary emergency pump**. It is sufficient for the cage to be manoeuvred away from the collision point to re-set the cage weigh mechanism, thereby restoring normal machine operation. The cage can now be lowered using the controls as described previously in Section 4.3.

FOLLOWING AN EMERGENCY DESCENT RECOVERY OF THE PLATFORM, FULLY EXTEND AND RETRACT ALL CYLINDERS FROM GROUND CONTROL STATION BEFORE USING THE MACHINE.



5.4 INCIDENT NOTIFICATION

It is a mandatory requirement that any accident or incident involving a Niftylift, regardless of whether any party received injury or property was damaged is reported by telephone directly to Niftylift. Failure to do so may render any warranty on the machine void.

6 Responsibilities

6.1 CHANGES IN OWNERSHIP

When a change of ownership of a Niftylift occurs, it shall be the responsibility of the seller to notify Niftylift directly of the unit, model and serial number and the name and address of the new owner within 60 days. This important step is required so that all future Technical Bulletins are able to reach the registered owner of each machine without delay. Please note warranties are not transferable.

6.2 MANUAL OF RESPONSIBILITIES (USA only)

You are required by ANSI/SIA 92.2 1990, to read and understand your responsibilities before you use or operate this aerial platform. Please read the enclosed document, as failure to do so could result in death or serious injury. Wherever any contradiction may appear, the Manual of Responsibilities shall take precedence over all other documents.

Operating & Safety Instructions

6.3 INSPECTION/SERVICE/PRE-HIRE CHECK LIST

MACHINE SERIAL NO _____

TOWING	PASS	FAIL	N/A
Machine secured on trailer			
Straps correctly positioned and tightened			
Wheels chocked if necessary			
AXLES, WHEELS AND BRAKES			
Wheels are secure, tyre condition acceptable			
Wheel bearings O.K.			
Brake linkages and cables secure			
Brake shoe wear not excessive			
Machine climbs slope			
Brakes hold machine on slope			
Rear hub nut secure			
Track rod secure, not fouling axle plate			
BASE			
Operation of ground control valve and buttons			
Operation of all booms over full range			
Wheel bearings OK			
Cylinders are silent			
Platform is level over full range			
Booms, levelling rods not damaged or distorted			
Booms levelling rods, cylinders not fouling			
Hoses not tight, kinked or fouled			
Operation of manual hand pump			
SLEWING			
Slew assembly and motor are secure			
Worm/wheel mesh correct, no excessive wear			
No end float of worm in housing			
Slew wheel bolts secure			
Slew guards secure			
PLATFORM			
Operation of control valve and buttons			
Operation of SiOPS			
Levelling lock valve holds in both directions, lines vented			
Operation of all booms over full range			
Cylinders are silent			
Platform levelling over full range			
Slewing smooth over full range			
Operation of boom 4 over full range (if fitted)			
No excessive movement of boom 4 and boom 3			

nifty Height Rider/SP Series
Operating & Safety Instructions

TILT ALARM	PASS	FAIL	N/A
Booms raised on slope - drive disabled, siren tone constant			
Boom operation unaffected			
Booms lowered - drive restored			
INTERNAL (POWER PACK)			
Power pack and all components secure			
All cables and terminals secure			
All hose connections secure			
Hoses not kinked or fouled			
Charger/control box secure			
Batteries secure			
Electrolyte level and specific gravity			
Charger operation (If applicable)			
Hydraulic oil level			
Engine/Gearbox oil			
FINISH			
Pivot pin tag bolts			
Correct decals, all visible			
Canopy/bonnets			
Grease nipples (Feet, Knuckle, Centre Post)			
LEAK CHECK			
Cylinders (Lift, Jacks, Telescope, Levelling)			
Control valves			
Check valves			
Power pack/pump			
Slew motor			
Hose connections			
Filter			
Wheel motors			

Comments, remedial work required etc;

INSPECTED BY: _____

DATE: / /

Appendix A

Code	Fault	Description	Action
00	Sounder Error	Open circuit or short circuit of the base sounder	Check wiring to the base sounder
01	Base Green Button, Bulb Error	Open circuit or short circuit of the base green button bulb	Check bulb is fitted Check wiring to the base green button bulb
02	Drive Enable Relay Error	Open circuit or short circuit of the drive enable relay coil	Check wiring to the drive enable relay coil on the PCB
03	Elevated Drive Solenoid Error	Open circuit or short circuit of the elevated drive solenoid	Check wiring to the elevated drive solenoid
04	Auxiliary Descent Error	Open circuit or short circuit of the auxiliary descent contactor	Check wiring to the auxiliary descent contactor
05	Machine Enable Relay 1 Error	Open circuit or short circuit of the machine enable relay1 coil	Check wiring to the machine enable relay1 coil on the PCB
06	Machine Enable Relay 2 Error	Open circuit or short circuit of the machine enable relay2 coil	Check wiring to the machine enable relay2 coil on the PCB
07	Horn Error	Open circuit or short circuit of the horn	Check wiring to the horn
08	Base Angle X Channel 1 Error	Error of the corresponding analogue input during PLC start up check	Check all connections to the tilt sensor - Reset power
09	Base Angle X Channel 2 Error	Error of the corresponding analogue input during PLC start up check	Check all connections to the tilt sensor - Reset power
10	Base Angle Y Channel 1 Error	Error of the corresponding analogue input during PLC start up check	Check all connections to the tilt sensor - Reset power
11	Base Angle Y Channel 2 Error	Error of the corresponding analogue input during PLC start up check	Check all connections to the tilt sensor - Reset power
12	Fuel Sender Error	Error of the corresponding analogue input during PLC start up check	Check all connections to the fuel sender - Reset power
13	Base Green Button Error	Error of the corresponding digital input during PLC start up check	Check wiring from the base green button - Reset power
14	Booms Down Switch Error	Error of the corresponding digital input during PLC start up check	Check wiring from the booms down switch (Normally Closed) - Reset power
15	Machine Enable OK1 Error	Error of the corresponding digital input during PLC start up check	Check wiring from the machine enable relay1 normally closed contact - Reset power

Code	Fault	Description	Action
16	Debug Error	Error of the corresponding digital input during PLC start up check	Check wiring from the debug core of the programming port - Reset power
17	Key switch Base Switch Error	Error of the corresponding digital input during PLC start up check	Check wiring from the 'base' side of the key switch - Reset power
18	Base ERROR_IO	Error on one of the inputs or outputs of the base PLC	Check screen for further fault codes - Diagnose further using the service tool
19	Base ERROR_ANALOG	Error on one of the analogue inputs to the base PLC	Check screen for further fault codes - Diagnose further using the service tool
20	Base ERROR_OUTPUTBLANKING	Error on one of the safety outputs of the base PLC	Check all connections to the relays on the base PCB and to the elevated drive solenoid
21	Axiomatic Valve Controller off the CANBus	The base PLC is not receiving the valve controller's 'present' signal	Check the power supply to the Axiomatic controller Check the CANBus connections from the base box to the Axiomatic controller
22	Screen off the CANBus	The base PLC is not receiving the screen's 'present' signal	Check the power supply to the screen Check the CANBus connections from the cage panel to the screen
23	Joystick off the CANBus	The base PLC is not receiving the joystick's 'present' signal	Check the power supply to the joystick Check the CANBus connections from the cage panel to the joystick
24	Chassis Node off the CANBus (Hybrid only)	The base PLC is not receiving the chassis node's 'present' signal	Check the power supply to the chassis node Check the CANBus connections from the base box to the chassis node Check address dials are set correctly
25	Motor / Engine Controller off the CANBus	The base PLC is not receiving the motor controller's 'present' signal (Hybrid) The base PLC is not receiving the engine node 'present' signal (Diesel)	Check the power supply to the motor controller (Hybrid) or engine node (Diesel) Check the CANBus connections from the base box to the motor controller (Hybrid) or engine node (Diesel)
26	Motor Controller Error (Hybrid only)	The motor controller has diagnosed an internal fault	Diagnose further using the service tool Use the LEDs on the motor controller to ascertain the fault code(s) (Red and Orange LEDs flash alternately) 1 red is followed by the first digit of the code 2 reds is followed by the second digit of the code

Operating & Safety Instructions

Code	Fault	Description	Action
27	ERROR_CAN_SAFETY	The control system has detected an error in the communication between the base and cage	Check that there is around 600ohms between CANH and CANL anywhere on the network Check there are no short circuits between CANH and CANL anywhere on the network Check address dials are set correctly
28	Cage ERROR_ANALOG	Error on one of the analogue inputs to the cage PLC	Check screen for further fault codes Diagnose further using the service tool
29	Cage Weigh Channel 1 Disconnected	The channel 1 cage weigh module is disconnected or faulty	Check the module is connected Check the wiring from the cage panel to the module
30	Cage Weigh Channel 2 Disconnected	The channel 2 cage weigh module is disconnected or faulty	Check the module is connected Check the wiring from the cage panel to the module
31	Tilt Sensor Disconnected	The tilt sensor is disconnected or faulty	Check the sensor is connected Check the wiring from the base box to the sensor
32	Telescope Switch Error	Switch inputs to the PLC do not oppose or switch in sync	Check wiring between switch and PLC Check switch operation
33	Telescope2 Switch Error	Switch inputs to the PLC do not oppose or switch in sync	Check wiring between switch and PLC Check switch operation
34	Cage ERROR_IO	Error on one of the inputs or outputs of the cage PLC	Check screen for further fault codes Diagnose further using the service tool
35	Cage Node off the CANBus	The base PLC is not receiving the cage node's 'present' signal	Check the power supply to the cage node Check the CANBus connections from the cage panel to the cage node
36	Parameter Error	Parameters do not match or incompatible selections have been made	Check on service tool that parameters are the same for base and cage Check that only one type of machine is selected (e.g. Hybrid, Diesel or Electric)
37	Serial Number Error	Serial numbers in base and cage PLCs do not match	Fit correct PLCs Change serial number in PLCs
38	Cage Weigh Error	Cage Weigh inputs to the PLC do not oppose or switch in sync	Check wiring between cage weigh PCB and PLC Check cage weigh PCB operation
39	Links Paddle Error	Paddle analogue outputs are not within spec of each other	Check paddle analogue voltages Use another paddle to check inputs to control system

Code	Fault	Description	Action
40	Luffing Paddle Error	Paddle analogue outputs are not within spec of each other	Check paddle analogue voltages Use another paddle to check inputs to control system
41	Slew Paddle Error	Paddle analogue outputs are not within spec of each other	Check paddle analogue voltages Use another paddle to check inputs to control system
42	Telescope Paddle Error	Paddle analogue outputs are not within spec of each other	Check paddle analogue voltages Use another paddle to check inputs to control system
43	Fly Paddle Error	Paddle analogue outputs are not within spec of each other	Check paddle analogue voltages Use another paddle to check inputs to control system
44	Base set to Download	The base run/download switch is set to download	Check switch is in RUN position Check that when the switch is in RUN, pin 24 of the PLC is 0v
45	Cage set to Download	The cage run/download switch is set to download	Check switch is in RUN position Check that when the switch is in RUN, pin 24 of the PLC is 0v
46	Base ERROR_POWER	The voltage supply to the base PLC has dropped below or is below 10V	Check power supply to PLC If Hybrid/Electric, check step down unit is operational and providing 14.3v to the control system
47	Cage ERROR_POWER	The voltage supply to the cage PLC has dropped below or is below 10V	Check power supply to PLC If Hybrid/Electric, check step down unit is operational and providing 14.3v to the control system
48	Base ERROR_VBBR	The base PLC is not seeing any voltage on pin 34	Check VBBR fuse in main box is OK Check wiring to and from the fuse
49	Cage ERROR_VBBR	The cage PLC is not seeing any voltage on pin 34	Check VBBR fuse on cage PCB is OK Check wiring to and from the fuse
50	Engine PLC Missing	The base PLC is not receiving the Engine PLC's 'present' signal	Check the power supply to the Engine PLC Check the CANBus connections from the base box to the Engine PLC

niftylift