

IQ LIFT

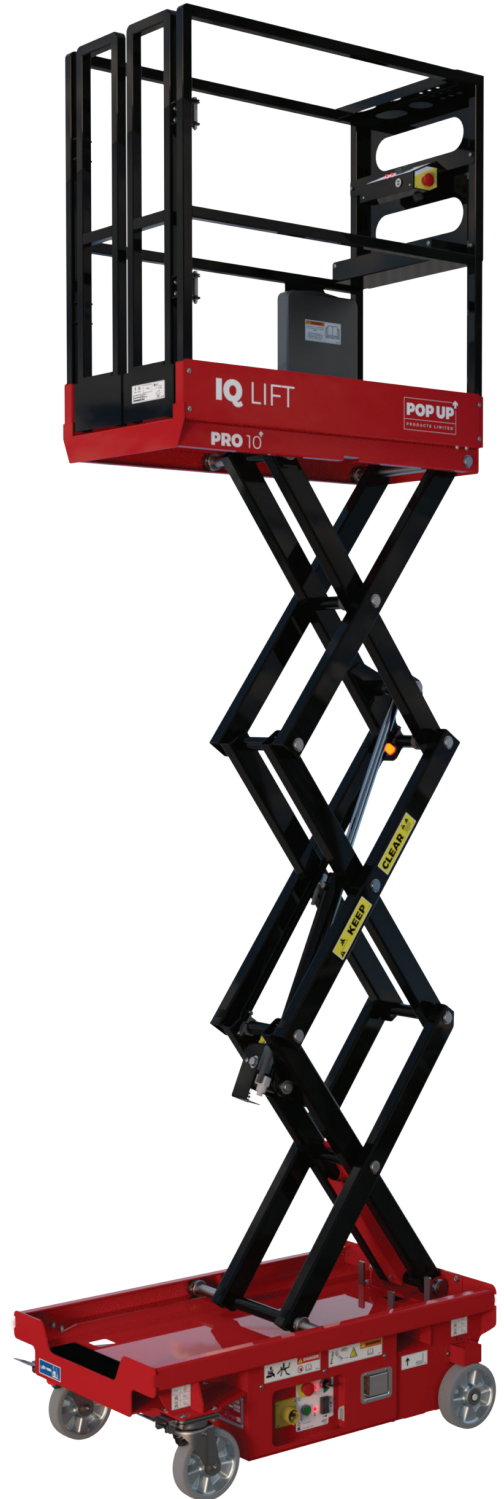

PRO 10[↑]

SN: E21-15001+

SUPO-758
REV C



+44 (0)1244 833 933



info@popupproducts.co.uk



popupproducts.co.uk

FOREWORD

Original instructions are written in English.

The purpose of this Operations and Safety Handbook is to provide users with the instructions and operating procedures essential to properly and safely operate the Mobile Elevating Work Platform for its intended purpose.

This handbook is considered part of the machine and must be stored on the machine at all times.

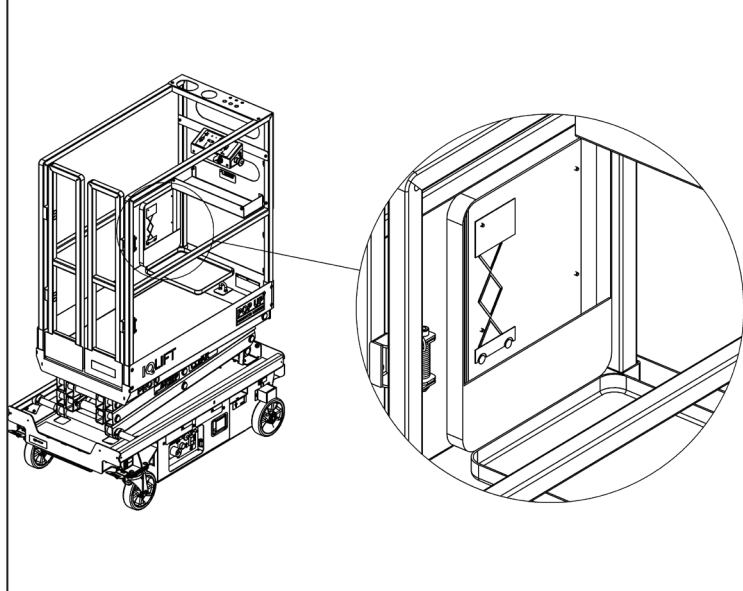

FIGURE 1: Handbook Storage Location



THE OPERATION AND SAFETY HANDBOOK MUST BE READ AND UNDERSTOOD PRIOR TO OPERATING THE MACHINE.

- The user/operator should not accept operating responsibility until the handbook has been read and understood as well as having operated the MEWP under supervision of an experienced and qualified operator.
- Because the manufacturer has no direct control over machine application and operation, proper safety practices are the responsibility of the user and all operating personnel.

If there is a question about application and/or operation, contact:

Pop Up Products Limited
Unit E1, Tenth Avenue
Deeside Industrial Park
Deeside
Flintshire
CH5 2UA

Tel. +44(0) 1244 833 933
E-mail - support@popupproducts.co.uk
Web - popupproducts.co.uk

FALL PROTECTION

Fall Protection Notice:

The guardrail system around the perimeter of the platform is the fall protection system for Mobile Elevating Work Platforms per the MEWP standard. It is prohibited to use this MEWP with any portion--or all--of the guardrails removed. Anchorage points are provided for work positioning restraints only. Lanyard lengths are to be determined by the operator/owner to restrict the operator to the confines within the guardrail system.

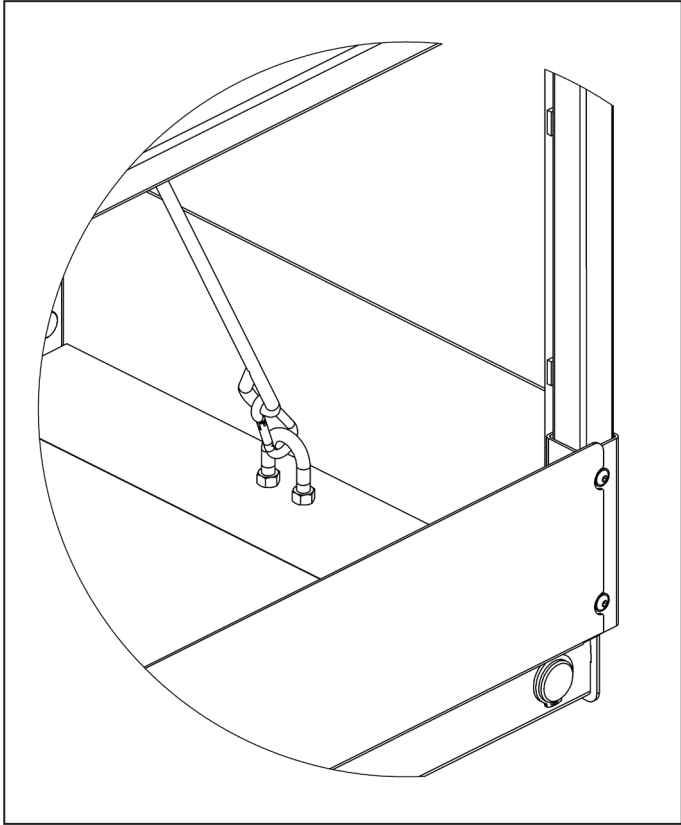

FIGURE 2: Anchorage



USE OF FALL ARREST SYSTEMS ATTACHED TO ANCHORAGE POINTS ON EQUIPMENT MAY CAUSE THE MACHINE TO TIP, RESULTING IN SERIOUS INJURY OR DEATH.

TABLE OF CONTENTS

NOTES	2
FOREWORD	4
FALL PROTECTION	5
TABLE OF CONTENTS	6
INDEX OF FIGURES	7
SECTION 1 PRODUCT DESCRIPTION	8
1.1 PRODUCT INFORMATION.....	8
1.2 MACHINE SPECIFICATIONS.....	9
SECTION 2 SAFETY	10
2.1 SAFETY SYMBOLS.....	10
2.2 GENERAL RULES AND PRECAUTIONS.....	10
2.3 SAFETY CONTROLS & INDICATORS.....	13
SECTION 3 TRANSPORT, HANDLING, & STORAGE	16
3.1 PRELIMINARY UNPACKING INSTRUCTIONS AND DEALER INSPECTION	16
3.2 STORAGE.....	16
3.3 PREPARATION FOR TRANSPORT.....	16
3.4 FORK LIFT POCKETS.....	16
3.5 LIFTING AND TIE-DOWN POINTS.....	17
SECTION 4 DECALS	18
4.1 DECAL LOCATIONS	18
4.2 DECAL SYMBOL MEANINGS	20
SECTION 5 OPERATION	24
5.1 BEFORE YOU OPERATE.....	24
5.2 WHEN WORK IS FINISHED	25
5.3 OPERATING CONTROLS & INDICATORS	26
SECTION 6 DAILY MAINTENANCE	28
6.1 DAILY MAINTENANCE.....	28
6.2 BATTERY CHARGING.....	29
SECTION 7 APPENDIX	30
7.1 PRE-START INSPECTION CHECKLIST	30

INDEX OF FIGURES

FIGURE 1: HANDBOOK STORAGE LOCATION	4
FIGURE 2: ANCHORAGE.....	5
FIGURE 3: MAINTENANCE LOCK.....	11
FIGURE 4: DESCENT WARNING LIGHT.....	13
FIGURE 5: EMERGENCY LOWERING.....	13
FIGURE 6: AUTOMATIC BRAKE.....	14
FIGURE 7: FORK POCKETS.....	16
FIGURE 8: TIE-DOWN	17
FIGURE 9: EXAMPLE SLING/LIFTING	17
FIGURE 10: CENTRE OF GRAVITY	17
FIGURE 11: DECAL LOCATIONS	18
FIGURE 12: PARKING BRAKE.....	24
FIGURE 13: PADLOCK EXAMPLE	25
FIGURE 14: PLATFORM CONTROLS/UPPER CONTROLS.....	26
FIGURE 15: GROUND CONTROLS/LOWER CONTROLS	27
FIGURE 16: BATTERY CHARGER CONNECTION AND CHARGER LIGHT LOCATIONS.....	29

SECTION 1 | PRODUCT DESCRIPTION

1.1 | PRODUCT INFORMATION

Pop Up Products' IQ Lift is a Mobile Elevating Work Platform designed to be safe and reliable. The purpose of the machine is to elevate personnel, along with their necessary tools and materials. The machine is intended for indoor use (no wind load). Manufacturer approval is required for any use other than the intended use.



ANY MODIFICATION OF THIS MACHINE WITHOUT THE EXPRESS WRITTEN CONSENT OF THE MANUFACTURER IS PROHIBITED.

1.2 | MACHINE SPECIFICATIONS

	IQ LIFT
Working Height (maximum)	4.97 m
Platform Height (maximum)	2.97 m
Stowed Height	1.75 m
Ground Clearance	66 mm
Overall Width	0.75 m
Overall Length	1.30 m
Work Platform	0.52 m x 1.04 m
Guard Rail Height	1.1 m
Toe Board Height	150 mm
Platform Entrance	0.64 m
Step Height	0.33 m
Wheel Base	1.01 m
Wheel Track	0.65 m
Turning Radius (Inside)	0 mm
Tyre Size (Solid, Non-Marking) - Front	200 mm
Tyre Size (Solid, Non-Marking) - Rear	200 mm

Rated Load	
Lift Capacity	240 kg 1 person + 160 kg tools and materials
Horizontal/Manual Force	200 N

Floor Loading*	
Machine Weight (Unloaded) (Approx.)	394 kg
Minimum Wheel Load — Contact Pressure	17.2 kg/ cm ²
Maximum Wheel Load — Contact Pressure	21.8 kg/ cm ²
Minimum Machine Loading — Floor Pressure	4.5 kPa
Maximum Machine Loading — Floor Pressure	5.7 kPa

*Machine Weight and Floor Loading may increase with some options (ex. battery)

Environmental limitations	
Wind	Indoor Use Only: 0 m/s
Rated Slope	1.5°
Temperature	-20° C- to 40° C
Vibration	Hand/Arm: 2.5 m/s ² max Whole Body: 0.5 m/s ² max
Sound Pressure Level at Workstation	86 dB Normal Use/100dB Alarms
Lift/Lower Speed	18 s / 20 s
Hydraulic Pressure (max)	12.4 MPa
Hydraulic Fluid Capacity	2.8 L
Power System — Voltage	12 V DC
Batteries — Deep Cycle Marine	(1) 12V, Group 27 WET CELL OR AGM



SECTION 2 | SAFETY

2.1 | SAFETY SYMBOLS

Warnings and instructions that have a direct impact on safety are identified with the following signals:



FAILURE TO FOLLOW THIS WARNING WILL CAUSE DEATH OR PERSONAL INJURY.

“DANGER” indicates an imminently hazardous situation, which, if not avoided, will result in death or serious injury.



FAILURE TO FOLLOW THIS WARNING MAY CAUSE DEATH OR PERSONAL INJURY.

“WARNING” indicates a potentially hazardous situation, which, if not avoided, could result in death or serious injury.



FAILURE TO FOLLOW THIS WARNING MAY CAUSE INJURY OR DAMAGE TO EQUIPMENT.

“CAUTION” indicates a potentially hazardous situation which, if not avoided, could result in minor or moderate injury or damage to equipment.

2.2 | GENERAL RULES AND PRECAUTIONS

An operator of any type of work platform is subject to certain hazards that cannot be protected by mechanical means. It is therefore essential that operators be competent, careful, physically and mentally fit, and thoroughly trained in safe operation of this machine. It is the responsibility of the owner to instruct operators with the safety requirements made not only in this handbook, but by the various safety bodies in your area, as well as additional requirements set forth by EN: 280. If you come across a situation that you think might be unsafe, stop the platform and request further information from qualified sources before proceeding.

Noise and vibration do not create significant hazards on this machine.



DO NOT OPERATE MACHINE NEAR POWER LINES. THE PLATFORM AND ENCLOSURES ARE NOT INSULATED.



NEVER REACH BETWEEN SCISSORS LINKS OR PROP UP PLATFORM.

Maintenance Lock

The maintenance lock must be placed into position whenever the machine is being serviced in a partially raised position. Serious injury and/or death could result if maintenance lock is not used properly.

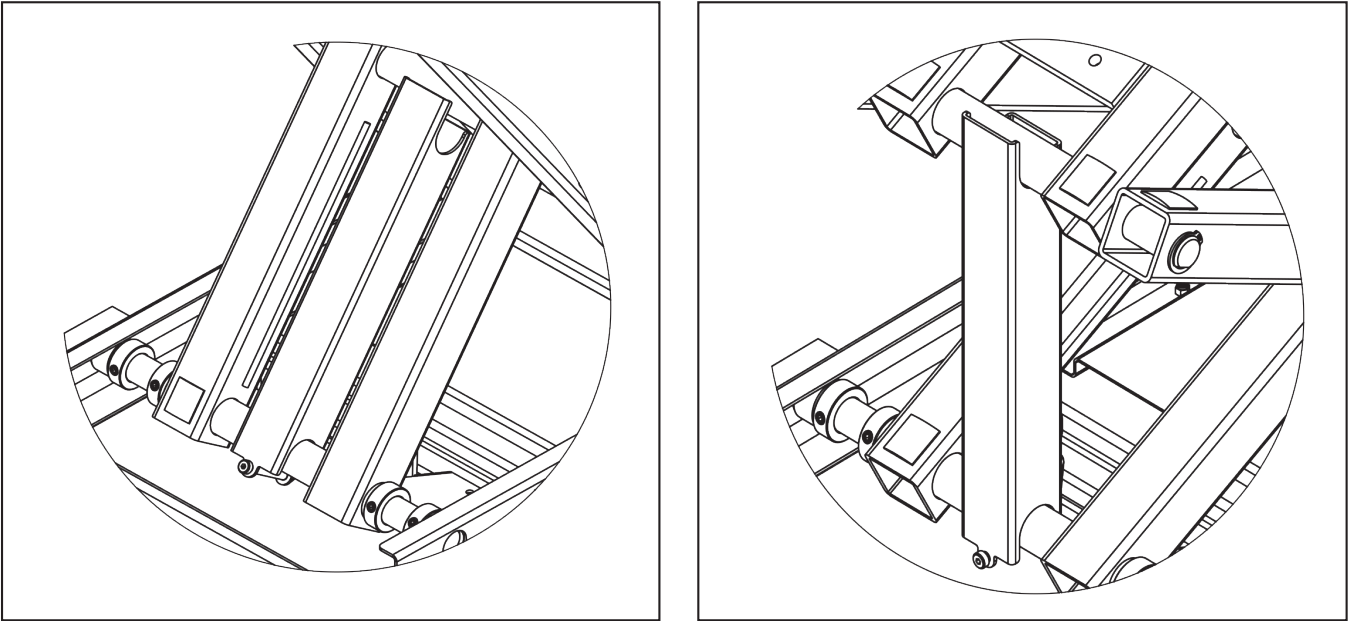

FIGURE 3: Maintenance Lock

SECTION 2 | SAFETY

Only qualified operators may operate this unit.

ALWAYS	read and understand the Operation and Safety Handbook before operating.
ALWAYS	understand all decals and warning labels on unit.
ALWAYS	prevent unauthorised use; when unit is not in use, remove key.
ALWAYS	wear necessary approved personal protective equipment (PPE), i.e. head gear.
ALWAYS	report any misuse of equipment to proper personnel.
NEVER	work on platform if your physical condition is such that you feel dizzy or unsteady.

Use machine only for purposes for which it was intended.

ALWAYS	distribute load evenly over platform floor area.
NEVER	use the lift as a crane (by suspending a load from the platform).
NEVER	exceed the load capabilities of the platform. (See the "Product Description" section of this handbook)
NEVER	use unit as electrical grounds for arc welding.
NEVER	override any hydraulic, mechanical, or electrical safety devices.

Check job site for unsafe working conditions.

ALWAYS	watch out for others. Keep others clear of operating platform.
ALWAYS	avoid contact with fixed (buildings, etc.) or moving (vehicles, cranes, etc.) objects. Check work area for overhead obstructions or possible hazards.
ALWAYS	follow any applicable national traffic regulations.
ALWAYS	be on hard level surface before elevating
ALWAYS	maintain a clearance between any part of the machine, or its load, and any electrical line or apparatus. Follow local power line clearance regulations.
NEVER	allow others to pass under a raised platform or position the platform over someone.
NEVER	use outdoors. Lift is not designed for windy conditions or electrical storms.
NEVER	operate on incline or uneven surface.
NEVER	operate machine near power lines. The platform and enclosures are not insulated.
NEVER	move the unit on a slope steep enough that the unit may become uncontrollable.

Equipment is only as safe as the operator.

ALWAYS	make sure entry gate is secured before operating machine from the platform.
ALWAYS	secure tools and materials.
ALWAYS	maintain a firm footing on the platform floor and work only within the platform area.
NEVER	use ladders or scaffolding on the platform to obtain greater height.
NEVER	enter or exit platform while machine is in motion.
NEVER	mount or dismount a raised platform.
NEVER	move the unit when in the elevated position.
NEVER	move the unit with a person on the platform.
NEVER	belt or tie off to an adjacent structure.

Before operation, ensure that the machine is properly serviced.

ALWAYS	perform inspections and preventative maintenance at the recommended intervals. (See the "Maintenance" section of this handbook)
ALWAYS	use the maintenance lock when performing all types of maintenance procedures.
NEVER	use machine if it is not working properly.
NEVER	smoke while charging the battery.

2.3 | SAFETY CONTROLS & INDICATORS

Emergency Stop

This lift is equipped with two emergency stop switches, one at the platform control and one at the base control, that when activated, will render the unit inoperable until reset. To reset, pull the button out. (See the “Operating Controls & Indicators” section of this handbook for more detail.

Descent Alarm & Lowering Interrupt

An audible alarm sounds when the machine is lowering.

When lowering the platform, the platform will stop when the ends of the scissors are 50mm apart for 3 seconds. The beacon light flashes to indicate the armguard delay. Release. Look around all sides of the scissors to check for persons at risk. Then continue lowering the platform. If elevating platform less than 50mm, the lift will not descend due to the armguard feature. Elevate the platform higher before lowering, or use the manual override in case of emergency.

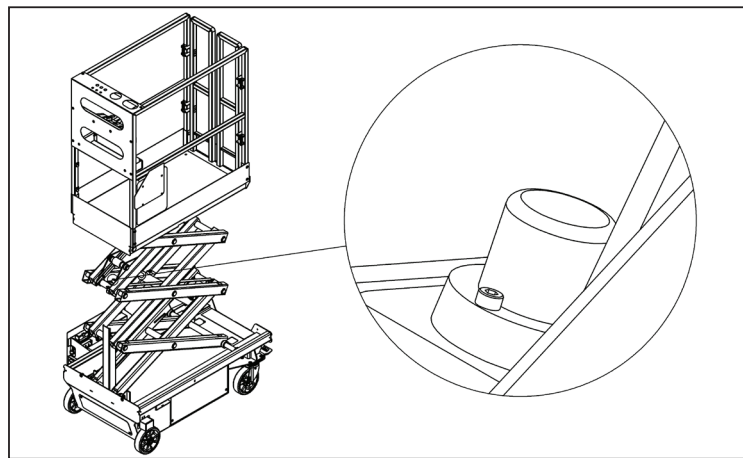

FIGURE 4: Descent Warning Light

Descent Manual Override(Emergency Lowering)

For manually lowering the scissors, a manual valve is provided. To lower the scissors, pull the cable located near the rear of the machine.

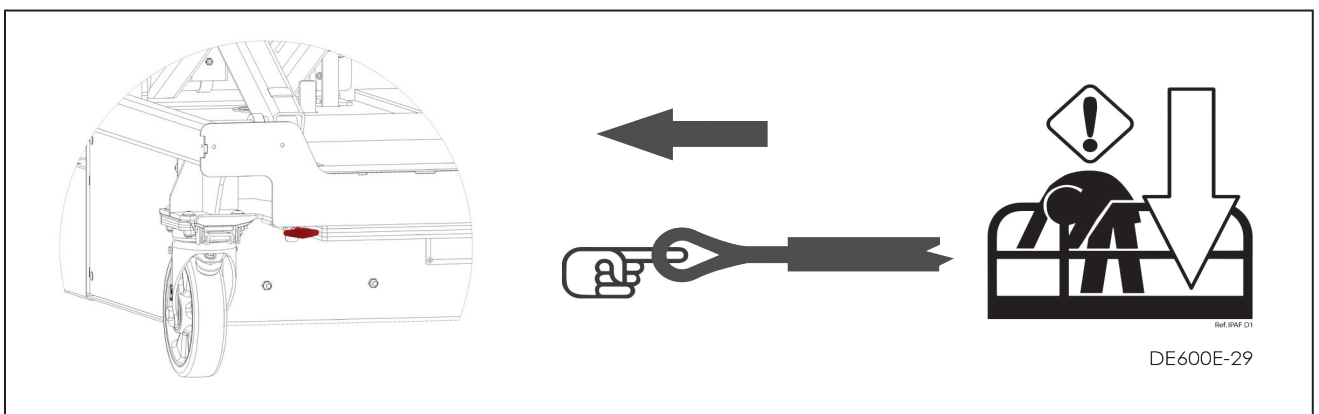

FIGURE 5: Emergency Lowering



IF PLATFORM SHOULD FAIL TO LOWER, DO NOT ATTEMPT TO CLIMB DOWN THE BEAM ASSEMBLY. SERIOUS INJURY MAY RESULT. HAVE AN EXPERIENCED OPERATOR USE THE EMERGENCY LOWERING PROCEDURE TO SAFELY LOWER THE PLATFORM.



Tilt Sensor

If the chassis is tilted more than 1.5°, elevating function is prevented, and an alarm sounds. Lower the platform and move to a hard, level surface before elevating.

Load Sensing

Movement is inhibited when the load exceeds the rated load and elevating is attempted from the stowed position. When the platform is stowed, the overload indicator lights up to indicate that the load control system is functional. Then attempting to elevate, if the load is less than rated load, the light will stop, and elevating may continue. If the rated load is exceeded, the light will continue and the platform will not elevate. Remove the excess load before continuing operation.

Automatic Brakes

When elevated, a brake is automatically applied to the rigid wheels. The manual parking brake on the swivel castors should also be used. (See the "Operation" section of this handbook).

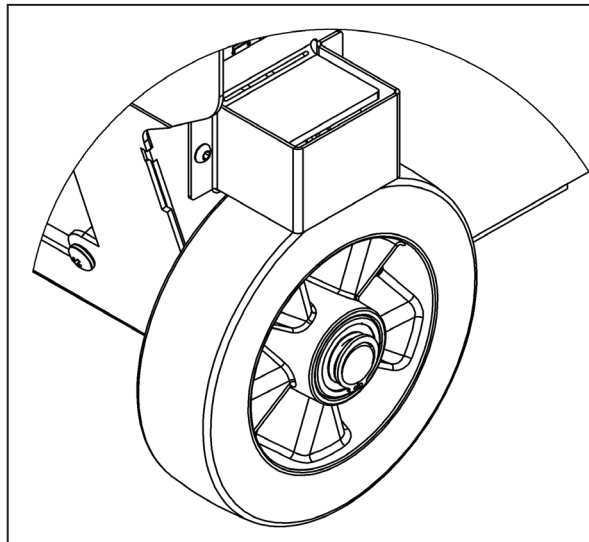

FIGURE 6: Automatic Brake

THIS PAGE WAS INTENTIONALLY LEFT BLANK

SECTION 3 | TRANSPORT, HANDLING, & STORAGE

3.1 | PRELIMINARY UNPACKING INSTRUCTIONS AND DEALER INSPECTION

Maintenance locks must be engaged prior to inspecting or servicing the unit when the platform is elevated. Inspect machine for any possible damage during shipment; perform a Pre-Delivery Inspection. See checklist in the Maintenance & Troubleshooting Handbook. Reset emergency stop switches, if necessary.

3.2 | STORAGE

After periods of storage, exposure to extremes of ambient conditions-heat, cold, moisture, dust etc., inspect the machine. Refer to the Pre-Delivery/ Frequent Inspection Checklist in the Maintenance & Troubleshooting Handbook.

3.3 | PREPARATION FOR TRANSPORT

- Lower the work platform to the down position.
- Turn key switch to off position.
- Check entire machine for loose or unsecured items. Remove any loose items from machine.
- For safety and controlled handling, it is not recommended to move the unit on a slope greater than 5°. Apply manual brake lock on rear castors.

3.4 | FORK LIFT POCKETS

Fork lift pockets are provided on the side of the unit for loading and unloading. When moving machine with a forklift, do not let machine slide along floor. Bring forklift to a stop and then gently lower the machine.

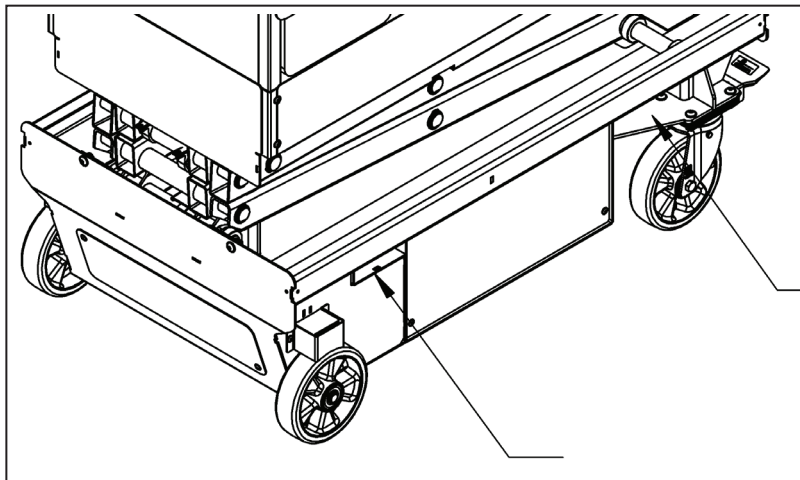

FIGURE 7: Fork Lift Pockets

3.5 | LIFTING AND TIE-DOWN POINTS

Tie-down points are provided in the front and rear of the machine for securing the machine on a trailer or truck bed for transport between places of use. They may also be used as lift points.

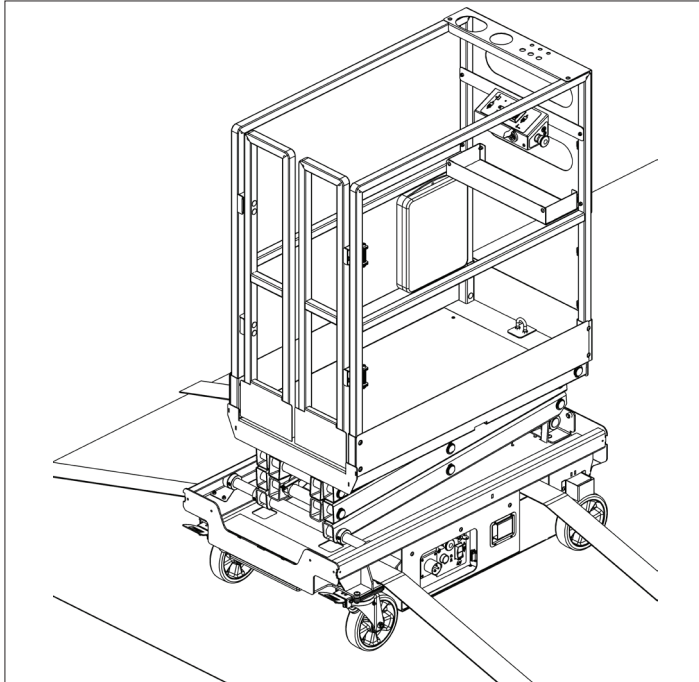

FIGURE 8: Tie-Down

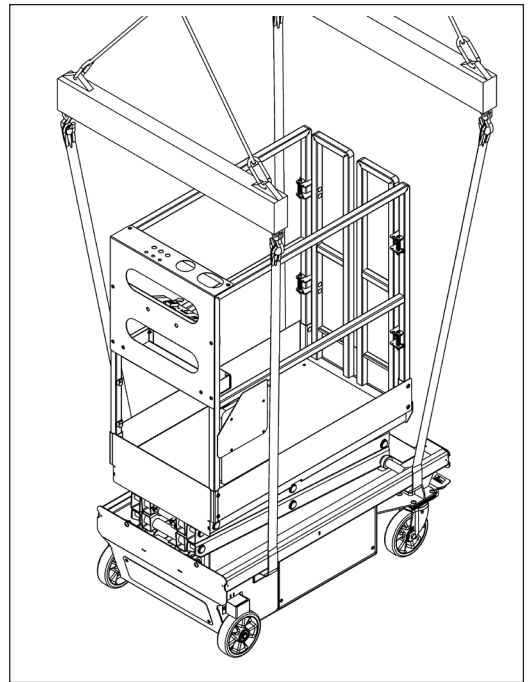

FIGURE 9: Example Sling/Lifting

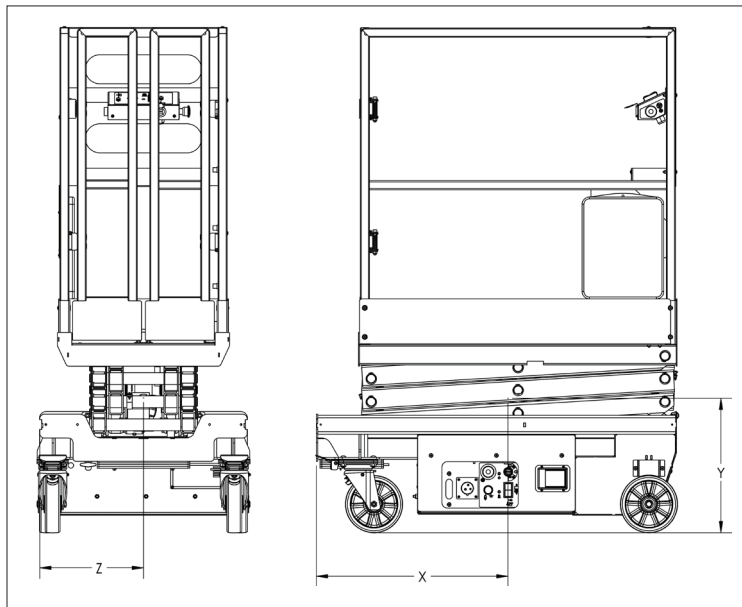

FIGURE 10: Centre of Gravity

Centre of gravity:

- X: 67 cm
- Y: 47 cm
- Z: 36 cm

SECTION 4 | DECALS

4.1 | DECAL LOCATIONS

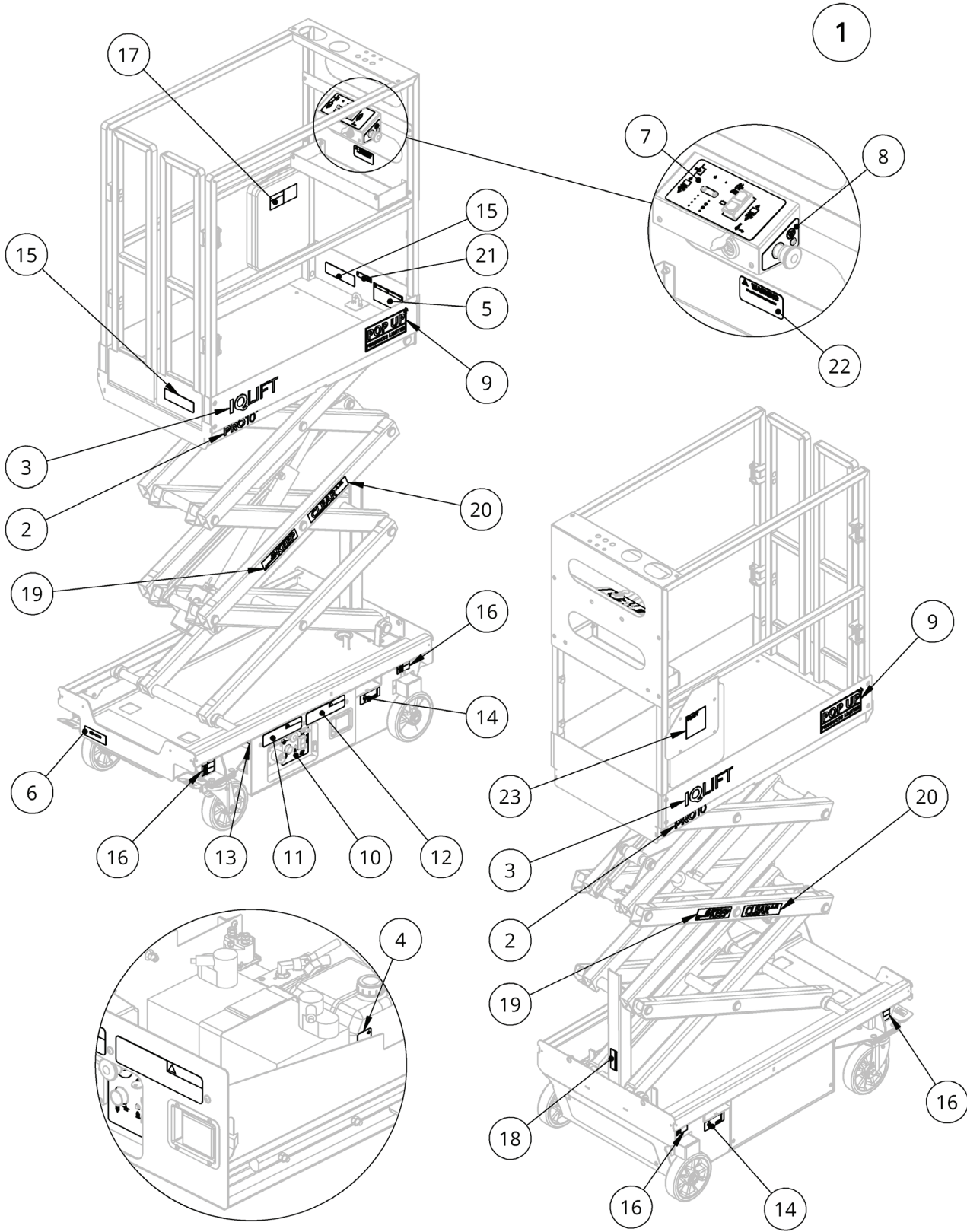

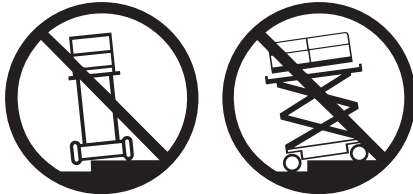

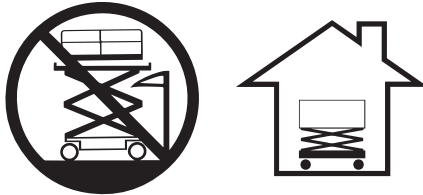
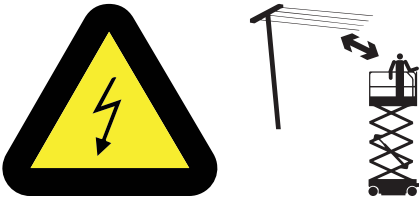



FIGURE 11: Decal Locations

ITEM NO.	PART NUMBER	DESCRIPTION	QTY
1	177-21-008-50-K	DECALS,IQ LIFT PRO 10	1
2	DE603-18	DECAL,MODEL PRO 10	2
3	DE603-19	DECAL,MODEL IQ LIFT	2
4	DE679	DECAL,HYDR FLUID	1
5	DE706	DECAL,UPR HB	1
6	DE751	DECAL,E-DOWN CABLE	1
7	DE812	DECAL,CTL UPR	1
8	DE813	DECAL,CTL UPR E-STOP	1
9	DE814	DECAL,LOGO POP-UP	2
10	DE815	DECAL,CTL LWR IQ LIFT	1
11	DE816	DECAL,LWR DANGERS	1
12	DE817	DECAL,LWR WARNINGS	1
13	DE818	DECAL,FORK	2
14	DE819	DECAL,FORK	2
15	DE828	DECAL,CAPACITY,530#,1P,I,WO/SO	2
16	DE829	DECAL,WHEEL LOAD IQ PRO 10	4
17	DE830	DECAL,HANDBOOK BOX	1
18	DE831	DECAL,MAINT LOCK	1
19	DE832	DECAL,KEEP	2
20	DE833	DECAL,CLEAR	2
21	DE834	DECAL,LANYARD ATTACHMENT,1P	1
22	DE835	DECAL,CAPACITY, TOOL TRAY	1
23	DE836	DECAL,IQ LIFT INFO	1

4.2 | DECAL SYMBOL MEANINGS

Symbol	Meaning
	<ul style="list-style-type: none"> • No Unauthorized Use • Do not operate this machine unless you have been trained in safe operation. • Training includes complete knowledge of the safety and operating instructions contained in the manufacturer's handbook, your employer's work rules, and applicable government regulations. • An untrained operator subjects himself and others to death or serious injury.
	<ul style="list-style-type: none"> • Read and understand all dangers and warning in the Operations & Safety Handbook before operating this machine. • Improper use of this machine could cause death or serious injury. • Inspect machine and make sure that it is operating properly, that all name plate and hazard signs are in place and legible, and that the machine is in accordance with the manufacturer's maintenance requirements contained in the operating and maintenance handbook and the daily safety checklist.
	<ul style="list-style-type: none"> • Lanyard anchorage point location. Capacity 1 person • Lanyard anchorage points are for work positioning restraints only. • Use of fall arrest systems attached to anchorage points on mobile • Equipment may cause machine to tip, resulting in serious injury or death.
	<ul style="list-style-type: none"> • Crushing Hazard • Do not enter the space beneath the work platform or scissor structure unless the maintenance lock is in place.
	<ul style="list-style-type: none"> • Refer to Maintenance & Troubleshooting Handbook • Only qualified service personnel may service the machine. Failure to comply with listed safety precautions may result in machine damage, personnel injury, or death. • Replace designated items with manufacturer's specified equipment only. Failure to use these items may cause instability and could void the Warranty.
	<ul style="list-style-type: none"> • Batteries produce explosive gas. Charge batteries in a well-ventilated area. • Do not expose sparks or flames. • Do not smoke while charging battery.
 <p data-bbox="292 1742 416 1760">110V AC / 50 HZ</p> <p data-bbox="292 1794 472 1812">230V / 240V AC / 50 HZ</p>	<ul style="list-style-type: none"> • Battery Charger Power Inlet
	<ul style="list-style-type: none"> • Tip Hazard

Symbol	Meaning
	<ul style="list-style-type: none"> • Tip Hazard • Do not elevate platform on a slope
	<ul style="list-style-type: none"> • Tip Hazard • Do not elevate platform on a slope.
	<ul style="list-style-type: none"> • Tip Hazard • Do not elevate platform on uneven or soft surfaces.
	<ul style="list-style-type: none"> • Indoor Use Only: No Wind Load
	<ul style="list-style-type: none"> • Electrocutation Hazard • This machine is not insulated. • Maintain safe clearance from electrical lines and apparatus. You must allow for machine sway, rock or sag and electrical lines swaying. • This machine does not provide protection from contact with or proximity to an electrically charged conductor. • You must maintain a clearance between any part of this machine or its load and any electrical apparatus. Follow local power line regulations. • Death or serious injury will result from contact or inadequate clearance.
	<ul style="list-style-type: none"> • Emergency Lowering
	<ul style="list-style-type: none"> • For safety and controlled handling, it is not recommended to move the unit on a slope greater than 5°.

SECTION 4 | DECALS

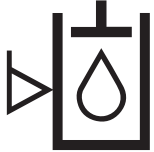
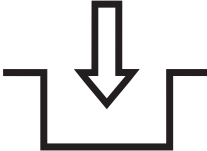
Symbol	Meaning
	<ul style="list-style-type: none">• Fork pocket
	<ul style="list-style-type: none">• Hydraulic oil level
	<ul style="list-style-type: none">• Hydraulic oil level

THIS PAGE WAS INTENTIONALLY LEFT BLANK

5.1 | BEFORE YOU OPERATE

Before use each day or at the beginning of each shift, the machine shall be given a visual inspection and functional test. Repairs (if any) must be made prior to operating the machine, as it is critical to ensure safe operation of the machine. A checklist for pre-start inspection can be found in the Daily Maintenance section of this handbook.



**THE OPERATOR MUST BE AWARE OF THE ENVIRONMENT.
DO NOT RAISE THE PLATFORM IF THE MACHINE IS NOT ON A FIRM,
LEVEL SURFACE.**

- Check that the work area is safe.
- It is not recommended to maneuver the unit on a slope greater than 5°.
- Machine must be on a hard, level, surface before operation.
- Engage the manual brakes on the rear castors before elevating the platform.

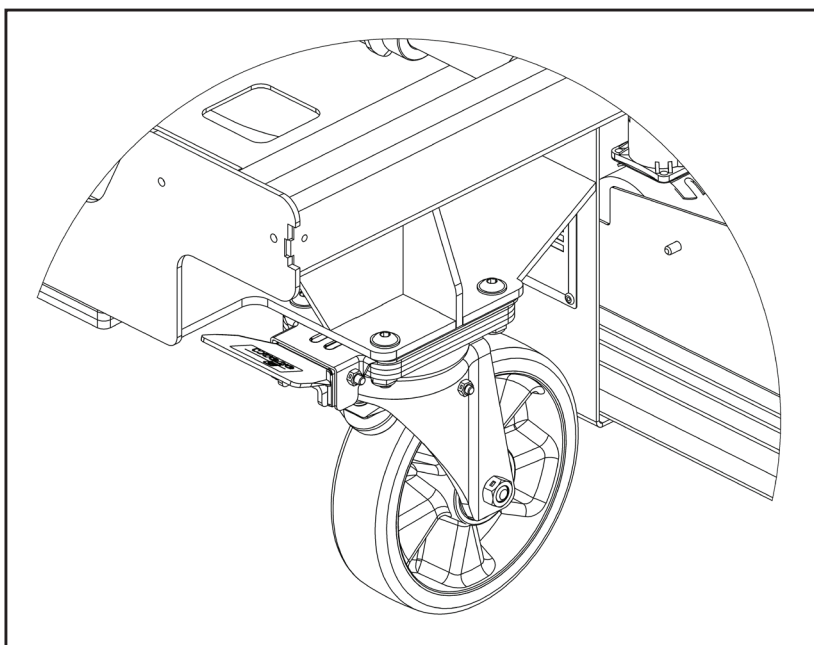

FIGURE 12: Parking Brake

- Ensure that the key in the lower control panel is in the "ON" position for the chassis or platform control.
- Enter the work platform in the stowed position using the constant three point contact method.
- Follow all general rules and precautions stated in this handbook.

5.2 | WHEN WORK IS FINISHED

- When finished with the machine, place the platform in the stowed position.
- Carefully exit the platform using the constant three point contact method.
- NEVER JUMP OFF PLATFORM.
- Park the machine on a level surface.
- Ensure that the manual brakes (on the rear castors) are engaged.
- Remove key from ground control panel to prevent unauthorised use. The key may be padlocked in the handbook box to secure in the isolated position.

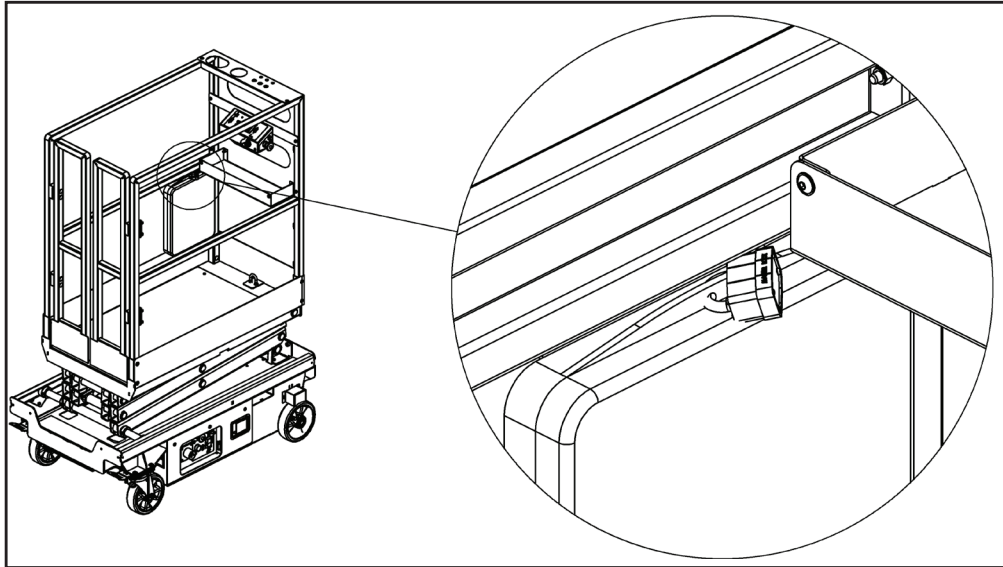

FIGURE 13: Padlock Example

5.3 | OPERATING CONTROLS & INDICATORS

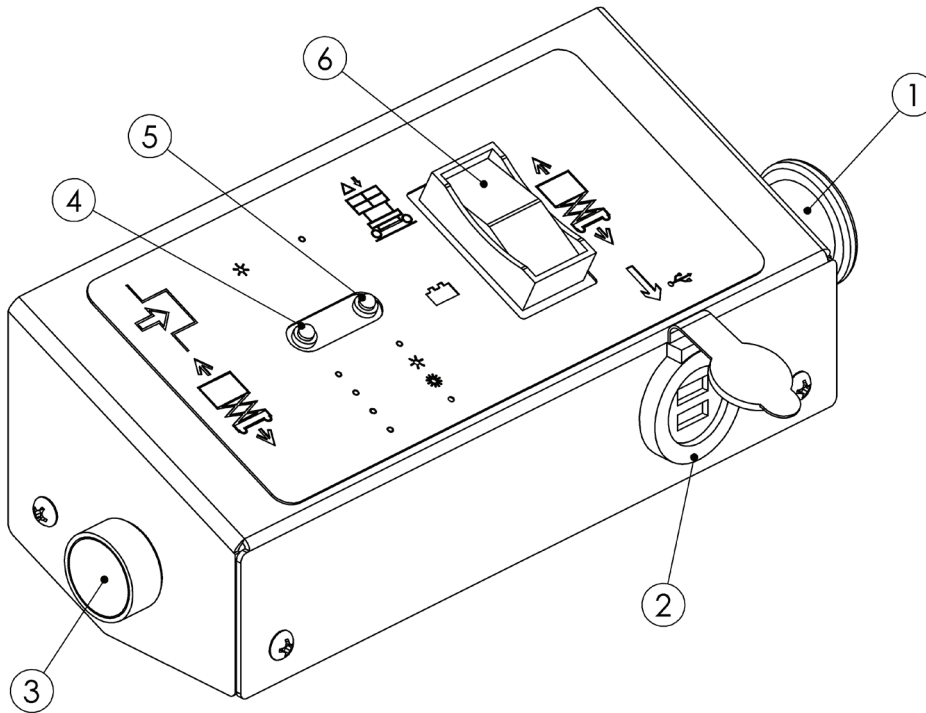

FIGURE 14: Platform Controls

Item	Control/Indicator
1	Emergency Stop Button Push in to stop all motion. Pull out to reset.
2	USB Power Port
3	Enable Button Push in to enable elevate and lower motion.
4	Overload Indicator Light Illuminates when stowed, beginning to elevate and checking for overload. If machine does not continue elevating and: Battery Indicator Light is on, the charge before continuing operation. Battery Indicator Light is off, remove excess load before continuing operation.
5	Battery Indicator Light Gives an approximate indication of battery charge: <ul style="list-style-type: none"> ○ Not Illuminated: 100% to 40% ◉ Slow Flash: 40% to 20% ◐ Fast Flash: 20% to 10% ● Steady: Less than 10%
6	Elevate/Lower Switch Push the top part of the rocker to elevate or the lower part to descend.

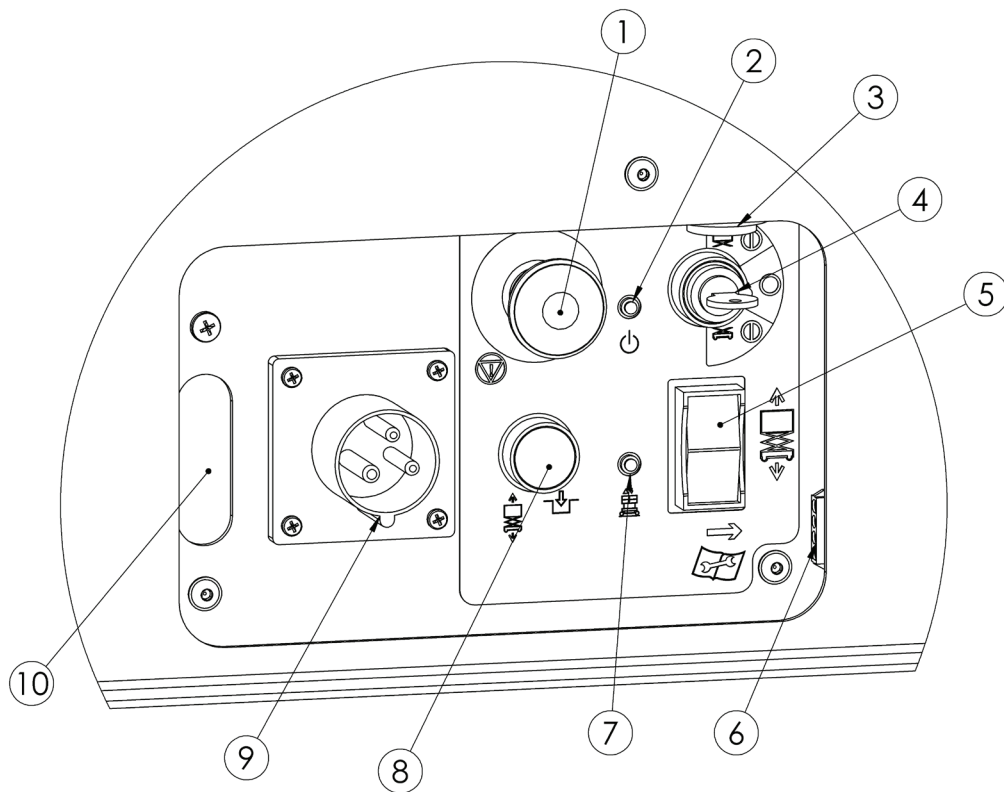

FIGURE 15: Ground Controls

Item	Control/Indicator
1	Emergency Stop Button Push in to stop all motion. Pull out to reset.
2	Power Indicator Light Illuminates when power is on.
3	Alarm Alarm sounds for descent, descent delay, or warning that machine is on a slope.
4	Key Switch Rotate the key to select Off, Platform or Ground Controls. Remove key to prevent unauthorised access.
5	Elevate/Lower Switch Push the top part of the rocker to elevate or the lower part to descend.
6	Diagnostic Connection Port Used for connecting EZ Cal diagnostic tool.
7	Overload Indicator Light Illuminates when stowed, beginning to elevate and checking for overload.
8	Enable Button Push in to enable elevate and lower motion.
9	Battery Charger Port See the "Battery Charging" section of this handbook
10	Charger Light Window See the "Battery Charging" section of this handbook

SECTION 6 | DAILY MAINTENANCE

6.1 | DAILY MAINTENANCE

Failure to perform inspections and preventative maintenance at recommended intervals may result in the unit being operated with a defect that may result in injury or death of the operator. Regular inspection and conscientious maintenance is important to efficient economical operation of this machine. It will help to assure that equipment will perform satisfactorily with a minimum of service and repair. Make checks at the stated intervals or more frequently if required by local operating conditions. A Pre-Start Inspection Checklist is included in this handbook.

Additional maintenance for use by trained personnel is included in a separate Maintenance & Troubleshooting Handbook. Refer to the Maintenance & Troubleshooting Handbook for Pre-Delivery/Frequent and Monthly Checklists and replacement part information.

6.2 | BATTERY CHARGING

This unit is equipped with a deep cycle 12-volt battery. The care and maintenance of your battery has much to do with how well this unit functions. Battery wiring should be checked monthly.

Note: The surrounding temperature greatly affects the power reserve within a battery.

EXAMPLE: A battery that is 100% charged at 27°C drops to 65% at 0°C. At -18°C, this battery will drop to 40% efficiency.



LEAD-ACID BATTERIES GENERATE EXPLOSIVE GASES. KEEP SPARKS AND FLAME AWAY FROM BATTERIES. DO NOT SMOKE WHILE CHARGING.

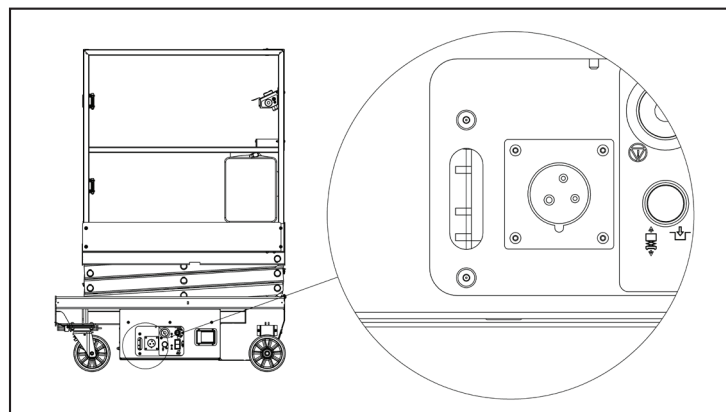

FIGURE 16: Battery Charger Connection and Charger Light Locations

Battery Charge Light Display

POWER	BATTERY 1 STATUS	
	CHARGING	READY
Green LED (ON)	Red LED (OFF)	Green LED (ON)

This display indicates that the power is on but there is no connection to a battery. The charger must see approximately five (5) volts on a battery to deliver D/C current.

POWER	BATTERY 1 STATUS	
	CHARGING	READY
Green LED (ON)	Red LED (ON)	Green LED (OFF)

This display indicates that power is on and that both outputs are delivering D/C current to the batteries.

POWER	BATTERY 1 STATUS	
	CHARGING	READY
Green LED (ON)	Red LED (OFF)	Green LED (ON)

This display indicates that power is on and that the output is finished charging and is in a float maintenance model.

SECTION 7 | APPENDIX

7.1 | PRE-START INSPECTION CHECKLIST

Pre-start Inspection (Push-Around Models)



THIS CHECKLIST MUST BE USED AT THE BEGINNING OF EACH SHIFT OR AFTER EVERY SIX TO EIGHT HOURS OF USE. FAILURE TO DO SO COULD AFFECT THE SAFETY OF THE OPERATOR.

Model: _____ Serial Number: _____

- Keep inspection records up-to-date.
- Record and report all discrepancies to your supervisor.
- A dirty machine cannot be properly inspected.

Y-Yes/Acceptable N-No/Unacceptable R-Repaired	Y	N	R
VISUAL INSPECTIONS			
Check that there are no damaged, dented, or bent structural members	<input type="checkbox"/>	<input type="checkbox"/>	<input type="checkbox"/>
There are no loose or missing parts.	<input type="checkbox"/>	<input type="checkbox"/>	<input type="checkbox"/>
Check that warning and instructional labels are legible and secure.	<input type="checkbox"/>	<input type="checkbox"/>	<input type="checkbox"/>
Check the platform rails and safety gate for damage.	<input type="checkbox"/>	<input type="checkbox"/>	<input type="checkbox"/>
Check that platform floor is clean to prevent slip, fall hazards	<input type="checkbox"/>	<input type="checkbox"/>	<input type="checkbox"/>
Platform and base controls are not missing, damaged, frayed, or disconnected.	<input type="checkbox"/>	<input type="checkbox"/>	<input type="checkbox"/>
Hydraulic hoses are not torn or loose, and there are no leaks. Check that hoses and cables have no worn areas or chafing.	<input type="checkbox"/>	<input type="checkbox"/>	<input type="checkbox"/>
Check the tyres for damage.	<input type="checkbox"/>	<input type="checkbox"/>	<input type="checkbox"/>
Check that all snap rings are secure in grooves on pivot pins.	<input type="checkbox"/>	<input type="checkbox"/>	<input type="checkbox"/>
FUNCTIONAL TESTS			
Gate closes automatically	<input type="checkbox"/>	<input type="checkbox"/>	<input type="checkbox"/>
Platform Controls: Check all switches and push buttons for proper operation.			
Emergency Stop (Stops all movement)	<input type="checkbox"/>	<input type="checkbox"/>	<input type="checkbox"/>
Up/Down Controls (Elevates, Lowers, Enable button must be pressed).	<input type="checkbox"/>	<input type="checkbox"/>	<input type="checkbox"/>
Base Controls: Check all switches and push buttons for proper operation.			
Emergency Stop (Stops all movement)	<input type="checkbox"/>	<input type="checkbox"/>	<input type="checkbox"/>
Key Switch (Selects Platform Control, Ground Control, or Off).	<input type="checkbox"/>	<input type="checkbox"/>	<input type="checkbox"/>
Alarm (Not damaged, sounds for descent).	<input type="checkbox"/>	<input type="checkbox"/>	<input type="checkbox"/>
Up/Down Rocker Switch (Elevates/Lowers, Enable button must be pressed).	<input type="checkbox"/>	<input type="checkbox"/>	<input type="checkbox"/>
Lowering Delay (Delay when lowering, re-activate descent switch to continue)	<input type="checkbox"/>	<input type="checkbox"/>	<input type="checkbox"/>
Emergency Lowering functions	<input type="checkbox"/>	<input type="checkbox"/>	<input type="checkbox"/>
Machine will not elevate when on a slope greater than 1.5°	<input type="checkbox"/>	<input type="checkbox"/>	<input type="checkbox"/>
Wheels: Front and rear wheels rotate freely.	<input type="checkbox"/>	<input type="checkbox"/>	<input type="checkbox"/>
Automatic brakes engage and hold when platform is elevated.	<input type="checkbox"/>	<input type="checkbox"/>	<input type="checkbox"/>
Parking Brakes (Swivel Castors) engage and hold	<input type="checkbox"/>	<input type="checkbox"/>	<input type="checkbox"/>

COMMENTS:

Date: _____ Inspected by: _____

PLEASE DUPLICATE THIS PAGE AS NEEDED FOR YOUR OWN USE.

THIS PAGE WAS INTENTIONALLY LEFT BLANK



IQ Lift PRO 10
Operations & Safety Handbook

© 2018 Pop Up Products Limited
Unit E1, Tenth Avenue
Deeside Ind Park
Deeside, Flintshire
CH5 2UA

Tel.:+44 (0) 1244 833933

E-mail - support@popupproducts.co.uk
Website - popupproducts.co.uk

Revision Date: June, 2018