



OPERATING MANUAL (CE)

TELESCOPIC BOOMS

MODELS **SJ66T**

170495AB-A March 2016



**ADVANCED
ACCESS PLATFORMS**

SKYJACK™

This manual is based on Serial Number(s):

SJ66T 97 001 396 – 97 001 832

Please refer to the website (www.skyjack.com) for older Serial Numbers.

Skyjack Service Center

3451 Swenson Ave. St. Charles,
Illinois, 60174 USA
Phone: 630-262-0005
Toll Free: 1-800-275-9522
Fax: 630-262-0006
Email: service@skyjack.com

Parts (North America)

Toll Free: 1-800-965-4626
Toll Free Fax: 1-888-782-4825
E-mail: parts@skyjack.com

Skyjack Australia Pty Ltd.

4 Coates Place
Wetherill Park
New South Wales 2164
Australia
Tel: +61 (0) 28786 3200
Fax: +61(0) 28786 3222

Parts & Service (Europe)

Unit 1 Maes Y Clawdd
Maesbury Road Industrial Estate
Oswestry, Shropshire SY10 8NN UK
Phone: +44-1691-676-235
Fax: +44-1691-676-238
E-mail: info@skyjackeurope.co.uk

Skyjack Brasil

Alameda Júpiter, 710
Loteamento American Park Empresarial
Indaiatuba, SP, Brasil 13347-653
Tel: +55 19 3936 0132

The Safety Alert Symbol identifies important safety messages on MEWP, safety signs in manuals or elsewhere. When you see this symbol, be alert to the possibility of personal injury or death. Follow the instructions in the safety message.



This Safety Alert Symbol means attention!

Become alert! Your safety is involved.



DANGER

DANGER indicates an imminently hazardous situation which, if not avoided, will result in death or serious injury.



WARNING

WARNING indicates a potentially hazardous situation which, if not avoided, could result in death or serious injury.



CAUTION

CAUTION indicates a potentially hazardous situation which, if not avoided, may result in minor or moderate injury. It may also be used to alert against unsafe practices.

IMPORTANT

IMPORTANT indicates a procedure essential for safe operation and which, if not followed, may result in a malfunction or damage to the MEWP.

Original instructions in English.

Table of Contents

Section 1 - About Your MEWP	5
Read and Heed	5
Safety Rules.....	6
Section 2 - Familiarization	11
2.1 Familiarization of Telescopic Boom Series.....	11
2.2 Component Identification	12
2.2-1 Drive Bypass Valve	12
2.2-2 Main Power Disconnect Switch	12
2.2-3 Brake System	12
2.2-4 Tilt Switch.....	13
2.2-5 Footswitch.....	13
2.2-6a Platform Load Sensing System.....	14
2.2-6b Overload Status Table	14
2.3 Visual & Daily Maintenance Inspections	19
2.4 Function Tests.....	27
2.5 Winching and Towing Procedure	37
2.6 Emergency Lowering Procedures.....	39
Section 3 - Operation	41
3.1 General	41
3.2 Major Components.....	42
3.3 Major Assemblies	43
3.4 Serial Number Nameplate	43
3.5 Component Identification	44
3.6 Component Identification (Optional Equipment/Attachments).....	45
3.7 Operator's Responsibility	47
3.8 Start Operation	48
3.9 Refueling Procedure.....	53
3.10 Loading/Unloading	54
3.11 Chassis Tilt.....	56
Section 4 - Tables	59
Table 4.1 Standard and Optional Features	59
Table 4.2a Specifications and Features	60
Table 4.2b Specifications and Features	61
Table 4.3 Owner's Annual Inspection Record.....	62
Table 4.4 Tire/Wheel Specifications	62
Table 4.5 Maximum Platform Capacities.....	62
Table 4.6 Floor Loading Pressure	63
Table 4.7 Maintenance and Inspection Schedule.....	64
Table 4.8 Operator's Checklist.....	65
Table 4.9 EC Declaration of Conformity.....	66
Section 5 - Labels	67

SKYJACK is continuously improving and expanding product features on its equipment, therefore, specifications and dimensions are subject to change without notice.

Mobile Elevating Work Platform (MEWP) Definition

A mobile device that has an adjustable position platform supported from ground level by a structure.

Purpose of Equipment

The SKYJACK Telescopic Boom Series (Model SJ 66T) MEWP is designed to transport and raise personnel, tools and materials to overhead work areas.

Use of Equipment

The MEWP is a highly maneuverable, mobile work station. Work platform elevation and elevated driving must only be done on a firm, level surface. It can be driven over uneven terrain only when the platform is fully lowered.

Manual

The operating manual is considered a fundamental part of the MEWP. It is a very important way to communicate necessary safety information to users and operators. A complete and legible copy of this manual must be kept in the provided weather-resistant storage compartment on the MEWP at all times.

Operator

The operator must read and completely understand both this operating manual and the safety panel label located on the platform and all other warnings in this manual and on the MEWP. Compare the labels on the MEWP with the labels found within this manual. If any labels are damaged or missing, replace them immediately.

Service Policy and Warranty

SKYJACK warrants each new SJ 66T series work platform to be free of defective parts and workmanship for the first 24 months. Any defective part will be replaced or repaired by your local SKYJACK dealer at no charge for parts or labor. Contact the SKYJACK Service Department for warranty statement extensions or exclusions.

Optional Accessories

The SKYJACK MEWP is designed to accept a variety of optional accessories. These are listed under “Standard and Optional Features” in [Table 4.1](#). Operating instructions for these options (if equipped) are located in [Section 3](#) of this manual.

For non-standard components or systems, contact the SKYJACK Service Department at

 : 44-1691-676-235

 : 44-1691-676-238

Include the model and serial number for each applicable MEWP.

Scope of this Manual

- a. This manual applies to the CE version of the Telescopic Boom MEWP models listed in [Table 4.1](#).
 - Equipment identified with “CE” meets the requirements of the Machinery Directive 2006/42/EC and the EMC Directive 2004/108/EC.
- b. Operators are required to conform to national, state or territorial/provincial and local health and safety regulations applicable to the operation of this MEWP.



WARNING

Failure to comply with your required responsibilities in the use and operation of the MEWP could result in death or serious injury!

Operator Safety Reminders

A study conducted by St. Paul Travelers showed that most accidents are caused by the failure of the operator to follow simple and fundamental safety rules and precautions.

You, as a careful operator, are the best insurance against an accident. Therefore, proper usage of this MEWP is mandatory. The following pages of this manual should be read and understood completely before operating the MEWP.

Common sense dictates the use of protective clothing when working on or near machinery. Use appropriate safety devices to protect your eyes, ears, hands, feet and body.

Any modifications from the original design are strictly forbidden without written permission from SKYJACK.

Electrocution Hazard

This MEWP is not electrically insulated. Maintain a Minimum Safe Approach Distance (MSAD) from energized power lines and parts as listed below. The operator must allow for the platform to sway, rock or sag. This MEWP does not provide protection from contact with or proximity to an electrically charged conductor.

**DO NOT USE MEWP AS A GROUND FOR WELDING.
DO NOT OPERATE MEWP DURING LIGHTNING OR STORMS.
DO NOT OPERATE THE MEWP NEAR POWER LINES. MAINTAIN A MINIMUM SAFE APPROACH DISTANCE (MSAD) FROM ENERGIZED POWER LINES.**



DANGER

Avoid Power Lines

Minimum Safe Approach Distance

CE Guidance Note

“Avoidance of danger from overhead lines”

Adhere strictly to the governmental rulings and regulations applicable in your country.

FAILURE TO AVOID THIS HAZARD WILL RESULT IN DEATH OR SERIOUS INJURY!

60023AE-CE

Safety Precautions

Know and understand the safety precautions before going on to next section.

**WARNING**

Failure to heed the following safety precautions could result in tip over, falling, crushing, or other hazards leading to death or serious injury.

- **KNOW** all national, state or territorial/provincial and local rules which apply to your MEWP and jobsite.
- **TURN** main power disconnect switch “O” off when leaving the MEWP unattended. Remove the key to prevent unauthorized use of the MEWP.
- **WEAR** all the protective clothing and personal safety devices issued to you or called for by job conditions.
- **DO NOT** wear loose clothing, dangling neckties, scarves, rings, wristwatches or other jewelry while operating this MEWP.



- **AVOID** entanglement with ropes, cords or hoses.



- **AVOID** falling. Stay within the boundaries of the guardrails.



- **DO NOT** raise the MEWP or operate elevated in windy or gusty conditions that exceed the limits specified in [Section 4, Table 4.5](#).



- **DO NOT** increase the lateral surface area of the platform. Increasing the area exposed to the wind will decrease MEWP stability. Avoid tenting.



- **DO NOT** elevate the MEWP if it is not on a firm, level surface.

- **DO NOT** drive elevated near depressions or holes of any type, loading docks, debris, drop-offs and surfaces that may affect the stability of the MEWP.



- **DO NOT** elevate or drive elevated on a slope. Elevated driving must be done on a firm, level surface.



- **If operation in areas with holes or drop-offs is absolutely necessary**, elevated driving shall not be allowed. Position the MEWP horizontally only with the platform fully lowered. After ensuring that all 4 wheels or outriggers (if equipped) have contact with a firm, level surface, the MEWP can be elevated. After elevation, the drive function must not be activated.



- **DO NOT** drive elevated on a soft or uneven surface.



- **DO NOT** ascend or descend a grade steeper than 50% (2WD & 4WD). Boom elevated driving must only be done on firm level surfaces.



Safety Precautions (Continued)

Know and understand the safety precautions before going on to next section.

- **DO NOT** operate an MEWP that has ladders, scaffolding or other devices mounted on it to increase its size or work height. It is prohibited.



- **DO NOT** exert horizontal (manual) force on MEWP that exceeds the limits specified in [Table 4.5](#).



- **DO NOT** use the MEWP as a crane. It is prohibited.



- **DO NOT** climb on boom arm assembly. It is prohibited.



- **DO NOT** sit, stand or climb on the guardrails. It is prohibited.



- **AVOID** overhead obstructions. Be aware of overhead obstructions or other possible hazards around MEWP when lifting or driving.



- **AVOID** crushing hazards. Be aware of crushing hazards when lifting or driving. Keep all body parts inside the MEWP.



- **BE AWARE** of blind spots when operating the MEWP.



- **ENSURE** that there are no personnel or obstructions in the path of travel, including blind spots.

- **DO NOT** lower the platform unless the area below is clear of personnel and obstructions.



- **DO NOT** use boom to push, pull other objects or to lift the chassis.



- **DO NOT** raise the MEWP while it is on a truck, forklift or other device or vehicle.



- **STUNT** driving and horseplay are prohibited.

- **DO NOT** use with improperly inflated/damaged tires or wheels. Refer to [Section 2: Wheel/Tire Assembly](#).



- **DO NOT** alter or disable limit switches or other safety devices.

- **DO NOT** use the MEWP without guardrails, locking pins and the entry gate in place.

Safety Precautions (Continued)

Know and understand the safety precautions before going on to next section.

- **DO NOT** exceed the rated capacity of the MEWP.



- **DO NOT** distribute load unevenly.



- **DO NOT** use under influence of alcohol or drugs.



- **DO NOT** attempt to free a snagged platform with lower controls until personnel are removed from the platform.

- **DO NOT** position the MEWP against another object to steady the platform.

- **DO NOT** place materials on the guardrails or materials that exceed the confines of the guardrails unless approved by Skyjack.

- **DO NOT** operate if MEWP is not working properly or if any parts are damaged or worn.



- **DO NOT** leave MEWP unattended with key in key switch.



Safety Precautions (Continued)

Know and understand the safety precautions before going on to next section.

Fall Protection

Skyjack recommends the use of a fall restraint system to keep an occupant within the confines of the platform, and thus not expose the occupant to any fall hazard requiring a fall arrest.

All personal fall protection equipment must comply with applicable governmental regulations and must be inspected and used in accordance with the manufacturer's recommendations.

All personal fall protection equipment must be attached only to approved anchorage points within the platform of the aerial platform.

**WARNING**

Entering and exiting the MEWP should only be done using the three points of contact.

- **Use only equipped access openings.**
- **Enter and exit only when the MEWP is in the fully retracted position.**
- Do use three points of contact to enter and exit the platform. Enter and exit the platform from the ground only. Face the MEWP when entering or exiting the platform.
- Three points of contact means that two hands and one foot or one hand and two feet are in contact with the MEWP or the ground at all times during entering and exiting.

**WARNING**

An operator should not use any MEWP that:

- **does not appear to be working properly.**
- **has been damaged or appears to have worn or missing parts.**
- **has alterations or modifications not approved by the manufacturer.**
- **has safety devices which have been altered or disabled.**
- **has been tagged or locked out for non-use or repair.**

Failure to avoid these hazards could result in death or serious injury.

Jobsite Inspection

- Do not use in hazardous locations.
- Perform a thorough jobsite inspection prior to operating the MEWP, to identify potential hazards in your work area.
- Be aware of moving equipment in the area. Take appropriate actions to avoid collision.

2.1 Familiarization of Telescopic Boom Series



WARNING

MEWP Familiarization should be given only to individuals who are QUALIFIED And TRAINED to operate an MEWP.

Do not operate this MEWP without proper authorization and training. Failure to avoid this hazard could result in death or serious injury.

It is the responsibility of the operator to read, completely understand and follow all instructions and warnings contained in this operating manual and on the MEWP.

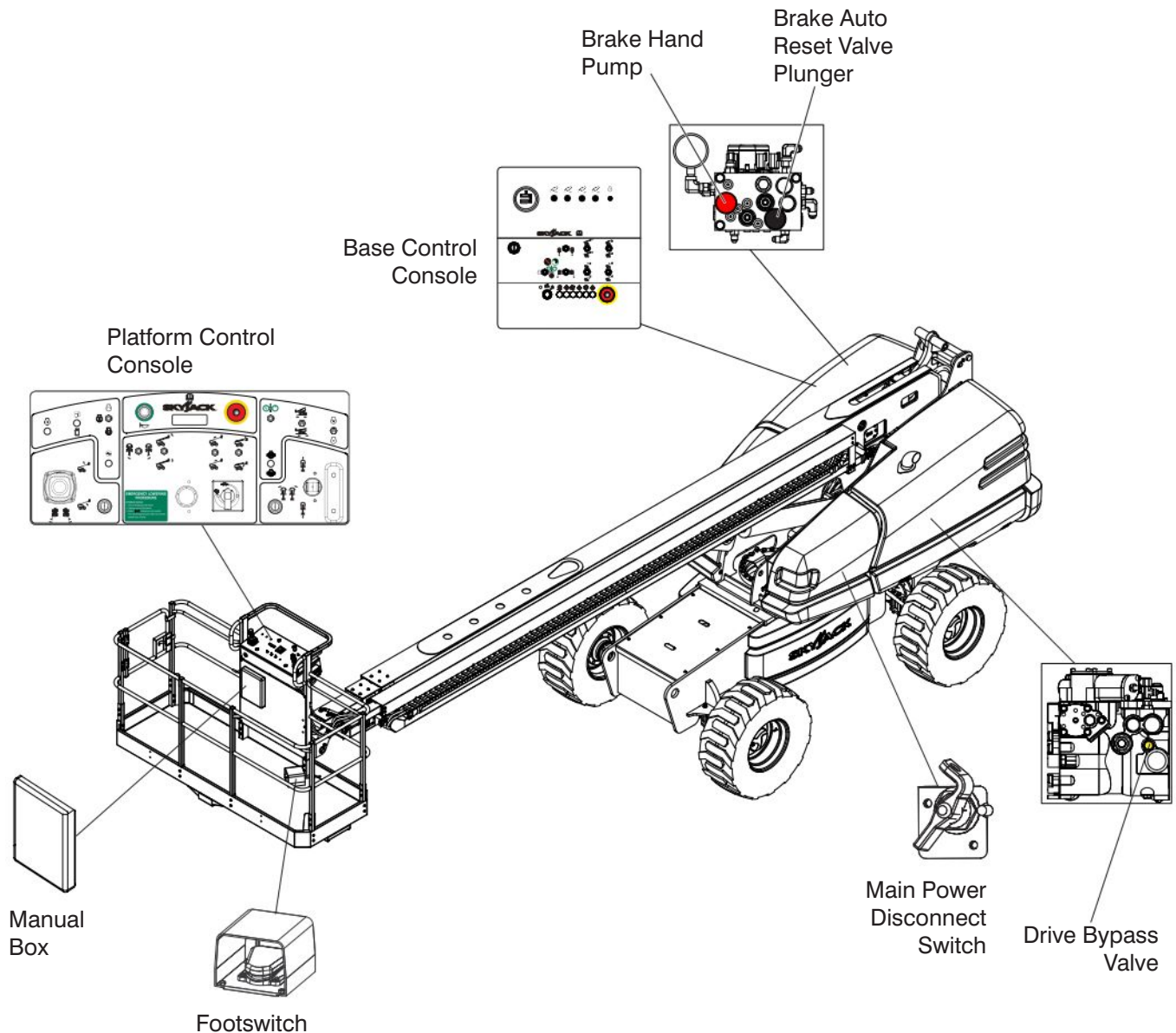

FAMILIARIZATION

2.2 Component Identification

The following descriptions are for identification, explanation and locating purposes only.

2.2-1 Drive Bypass Valve

This valve is located on the inboard side of the drive pump and can be identified with a yellow paint mark on it.

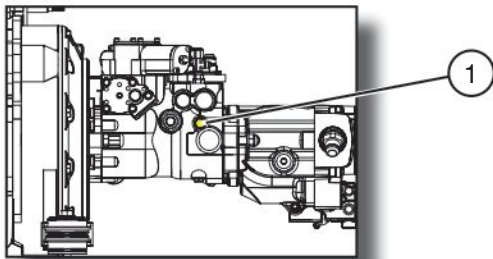

Figure 2-1. Drive Bypass Valve

1. **Drive Bypass Valve with Override Stems** - This valve, when loosened two revolutions counterclockwise, is used to override drive relief valves so that the MEWP can be loaded or unloaded from a trailer using a winch line.

2.2-2 Main Power Disconnect Switch

This switch is located in the engine compartment near the batteries.

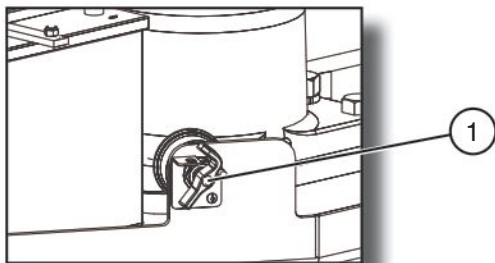

Figure 2-2. Main Power Disconnect Switch

1. **Main Power Disconnect Switch** - This switch, when in “○” off position, disconnects power to all circuits. Switch must be in “|” on position to operate any circuit. Turn switch “○” off when transporting MEWP.

2.2-3 Brake System

The brake system is located in the control compartment. The brakes must be manually disengaged before pushing, winching or towing. Refer to [Section 2.5-1](#) for procedure on how to release brakes manually. The system contains the following controls:

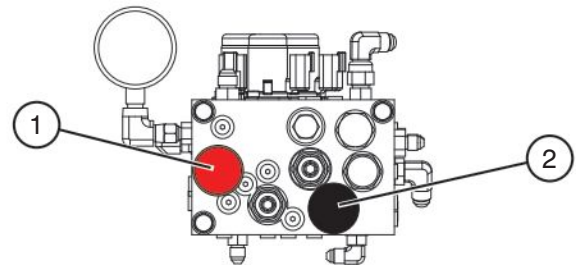

Figure 2-3. Brake System

1. Brake Hand Pump
2. Brake Auto Reset Valve Plunger

2.2-4 Tilt Switch

The tilt sensor is located inside the base control console. It is designed to prevent driving when MEWP is on a slope greater than a predetermined limit.



WARNING

If MEWP becomes tilted causing alarm to sound, the platform must be fully lowered immediately. Ensure that MEWP is on a firm level surface before operating the MEWP. Refer to Section 3.11 for instructions regarding recovery from an inclined position.

2.2-5 Footswitch

The footswitch is located on the floor of the platform. When depressed and held, it enables controls on platform control console.

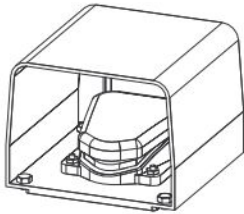

Figure 2-4. Footswitch

NOTE

The footswitch is equipped with a 15-second anti-tiedown feature that deactivates footswitch when operator depresses it for 15 seconds without activating any function.

2.2-6a Platform Load Sensing System

The platform load sensing system is a device that senses for an overload on the platform before the system disables boom and drive functions. This system is active when MEWP is powered on.

If the platform is overloaded while in work mode (boom is raised greater than 15 degrees from horizontal or is extended greater than 6 inches), the load sensing system will disable all normal functions and signal the operator with an indicator light and an audible alarm.

If the platform is overloaded while in travel mode, the load sensing system will signal the operator with an indicator light and an audible alarm but will not disable any normal functions.

The following table shows the progression of warnings, indicated to the operator, up to the point of overload.

2.2-6b Overload Status Table

Weight	Indicator Light	Audible Alarm	Platform Function Controls
93% - 99%	On	Off	Enabled
100%	Flashing	Off	Enabled
≥ 100% (Work Mode)	Flashing	Pulsing	Disabled
≥ 100% (Travel Mode)	Flashing	Pulsing	Disabled

1133AA-CE



WARNING

Do not operate emergency power unit if platform capacity is exceeded. If the platform is overloaded due to contact with an overhead obstruction, do one of the following:

- **Remove the obstruction from the platform, then after a four-second delay normal functions can be resumed.**
- **Use the emergency power unit at the base control console to release the platform from the obstruction.**

2.2-7 Base Control Console

This control console is located in the panel mounted in the control compartment.

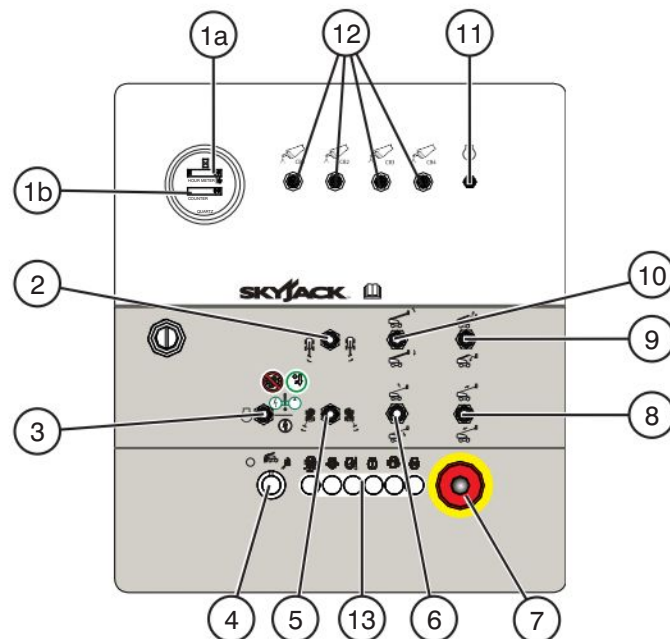



















Figure 2-5. Base Control Console

- 1a. **Hourmeter** - This gauge records accumulated operating time of engine.
- 1b. **Emergency Lowering Counter** - This gauge increments each time the emergency power unit is activated while MEWP is in work mode and overloaded.
2. **Platform Rotation Switch** - This switch controls  left or  right rotation of platform.
3. **Start/Function Enable/Emergency Power Switch** - This momentary switch, when held in  start position, starts engine. When held in  function enable position, allows base control functions to operate. Engine speed increases when selected. With engine off, and when held in  emergency power unit position, allows base control functions to operate using emergency power unit.
4. **Off/Base/Platform Key Switch** - This three-way selector switch allows operator to  turn off power to MEWP or to activate either  base or  platform control console.
5. **Turret Rotation Switch** - This switch controls  left or  right rotation of turret.
6. **Main Boom Raise/Lower Switch** - This switch controls  raising or  lowering of main boom.
7. **Emergency Stop Button** - This red “mushroom-head”  pushbutton disconnects power to control circuit and shuts engine off.
8. **Fly Boom Extend/Retract Switch** - This switch controls  extension or  retraction of fly boom.
9. **Jib Up/Down Switch** - This switch controls  up or  down movement of jib.



WARNING

Do not operate boom functions if platform capacity is exceeded.

2.2-7 Base Control Console (Continued)

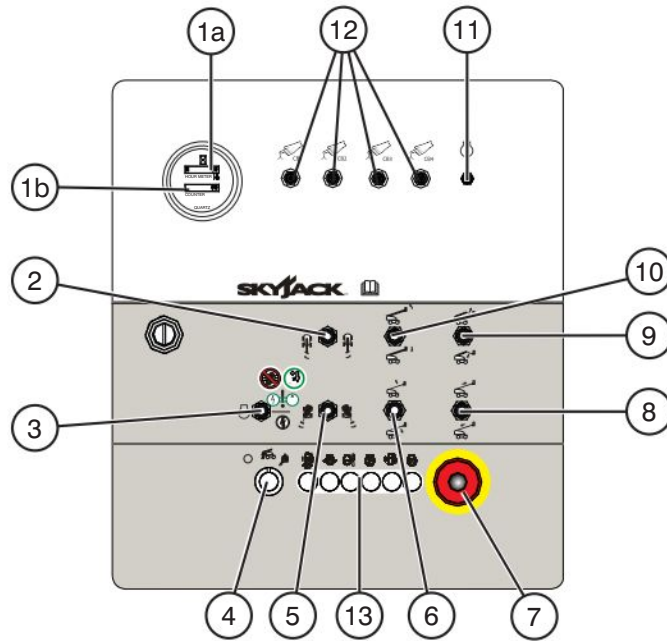





Figure 2-5. Base Control Console

10. Platform Leveling Override Switch - This switch overrides automatic leveling of platform and controls “” tilting up or “” tilting down of platform.

11. Engine Diagnosis Switch - When held in either direction, this switch “” enables an error blink code for engine control unit (ECU).

12. Circuit Breakers - In the event of a power overload or positive circuit grounding, the circuit breaker pops out. Push breaker back in to reset.

13. Status Indicator Pilot Lights - These lights indicate operational status and errors in any function in the controls/engine.

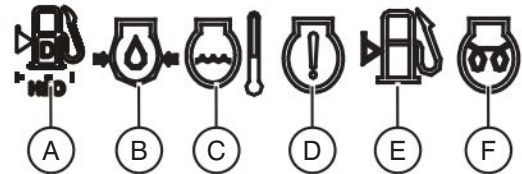

A. Water In Fuel Light - This light indicates water separator is full. Open drain to release water. Engine damage could occur if ignored for excessive length of time.

B. Engine Oil Pressure - This light indicates low engine oil pressure.

C. Engine Coolant Temperature/Level - This light indicates overheating of engine coolant and low level of engine coolant.

D. Engine - This light indicates failure in engine control system.

E. Fuel - This light indicates low fuel level.

F. Glow Plug (Diesel) - This light illuminates until glow plugs have completed their timed cycle. When the lamp goes out, the engine is ready to be started.

2.2-8 Platform Control Console

This control console is mounted at front guardrail of the platform. It has the following controls:

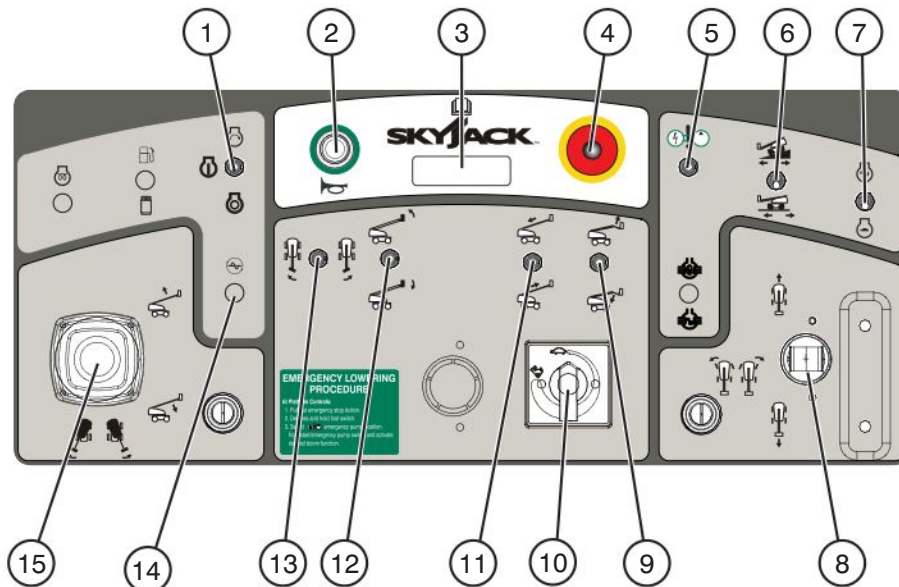



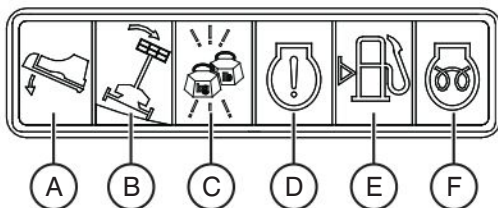





Figure 2-6. Platform Control Console

- 1. **Engine Start/On/Off Switch** - This switch, when held momentarily in “” start position, starts engine. Once started, the switch returns to “” on position. When in “” off position, it turns engine off.
- 2. **Horn Pushbutton** - This “” pushbutton sounds an automotive-type horn.
- 3. **Status Indicator Pilot Lights** - These lights indicate operational status and errors in any function in the controls/engine.



- A. **Footswitch** - This light illuminates when footswitch is depressed. A 15-second anti-tiedown feature deactivates footswitch when operator depresses it for 15 seconds without activating any function.

- B. **Chassis Tilt** - This light illuminates when the MEWP chassis is at an inclination that activates the tilt sensor. At this inclination, an audible alarm will sound at the platform. Refer to [Section 3.11](#) for instructions regarding recovery from an inclined position.
- C. **Overload Light** - This red light indicates overload status. Refer to [Section 2.2-6](#).
- D. **Engine** - This light indicates failure in engine control system.
- E. **Fuel** - This light indicates low fuel level.
- F. **Glow Plug (Diesel)** - This light illuminates until glow plugs have completed their timed cycle. When the lamp goes out, the engine is ready to be started.

- 4. **Emergency Stop Button** - This red “mushroom-head” “” pushbutton disconnects power to control circuit and shuts engine off.
- 5. **Emergency Power Unit** - This switch “” enables emergency power unit.
- 6. **Torque Switch** - This switch selects “” low or “” high torque.

2.2-8 Platform Control Console (Continued)

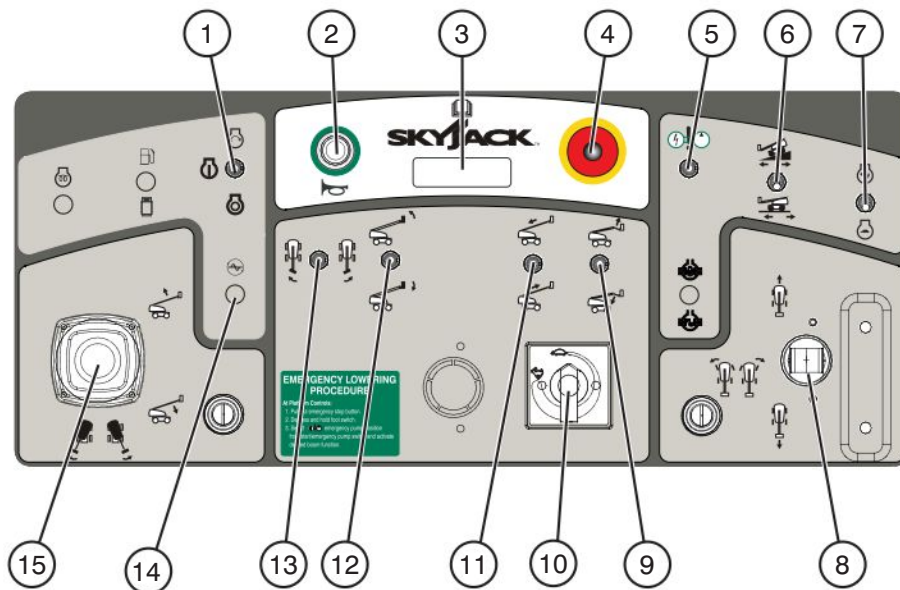





















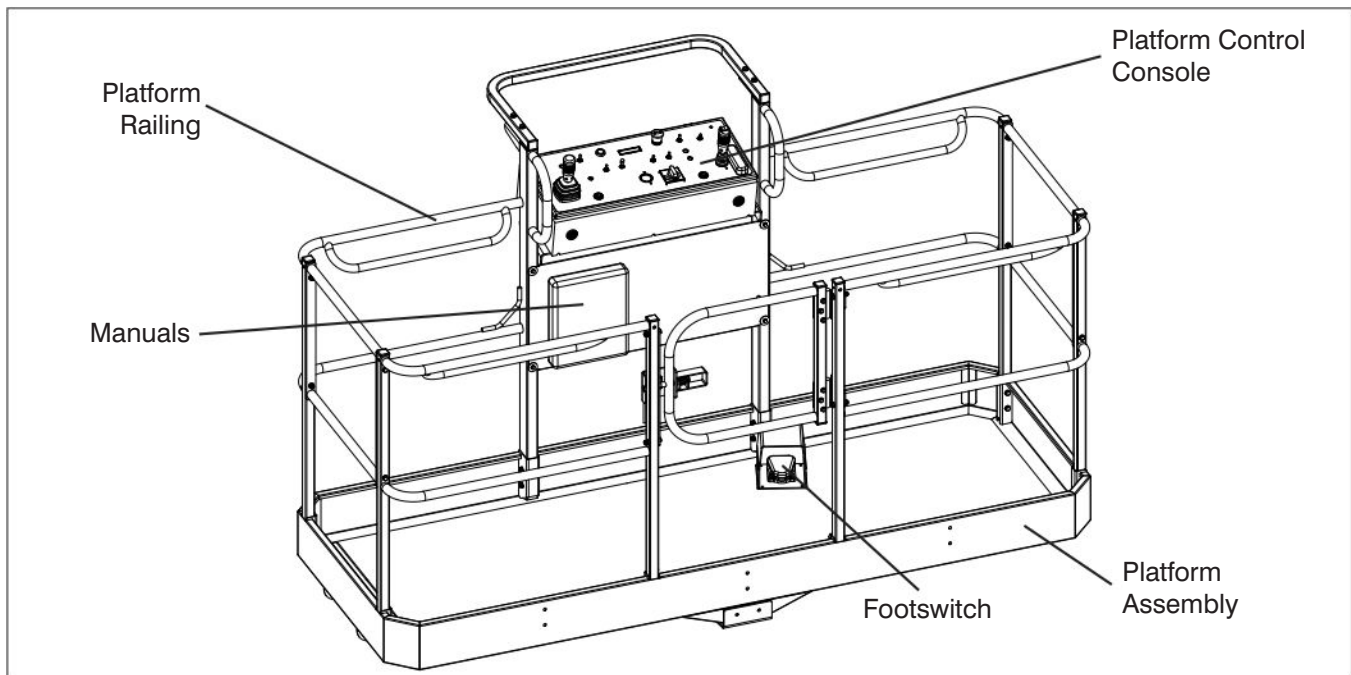

Figure 2-6. Platform Control Console

7. **Low/High Throttle Switch** - This switch allows selection between “” low and “” high engine throttle speeds.
8. **Drive/Steer Controller** - This single-axis lever controls driving “” forward or “” backward. The rocker switch controls steering “” left or “” right. Internal springs return it to neutral when stick is released.
9. **Jib Up/Down Switch** - This switch controls “” up or “” down movement of jib.
10. **Function Speed Adjuster Dial** - This variable-speed adjuster “” controls speed of fly boom extension/retraction, jib raising/lowering and platform rotation movements. This is used with switches 9, 11 and 13.
11. **Fly Boom Extend/Retract Switch** - This switch controls “” extension or “” retraction of fly boom.
12. **Platform Leveling Override Switch** - This switch overrides automatic leveling of platform and controls “” tilting up or “” tilting down of platform. To activate platform leveling override, lift and move switch.
13. **Platform Rotation Switch** - This switch controls “” left or “” right rotation of platform.
14. **Generator On/Off Switch (If Equipped)** - This switch turns the hydraulic generator “” on or “” off.
15. **Boom/Turret Controller** - This dual-axis lever controls “” raising or “” lowering of main boom or rotating “” left or “” right of turret.



2.3 Visual & Daily Maintenance Inspections

Begin the visual and daily maintenance inspections by checking each item in sequence for the conditions listed in this section.



WARNING

To avoid injury, do not operate an MEWP until all malfunctions have been corrected.



WARNING

To avoid possible injury, ensure MEWP power is off during your visual and daily maintenance inspections.



CAUTION

Ensure MEWP is on a firm, level surface.

NOTE

While doing visual and daily inspections in different areas, be aware to also inspect limit switches, electrical and hydraulic components.

2.3-1 Labels

Refer to [Section 5 - Labels](#) section in this manual and determine that all labels are in place and are legible.

2.3-2 Electrical

Maintaining the electrical components is essential to good performance and service life of the MEWP.

Inspect the following areas for chafed, corroded and loose wires:

- boom to platform cable harness
- engine compartment electrical panel
- engine wiring harness
- rotary manifold wiring

2.3-3 Limit Switches

Ensure limit switches are properly secured with no signs of visible damage and movement is not obstructed.

2.3-4 Hydraulic

Maintaining the hydraulic components is essential to good performance and service life of the MEWP.

Perform a visual inspection around the following areas:

- hydraulic tank filter, fittings, hoses, emergency power unit and turret/base surface
- engine compartment fittings, hoses, main pump, filter and turret/base surface
- all hydraulic cylinders
- all hydraulic manifolds
- the underside of the turret
- the underside of the base
- ground area under the MEWP

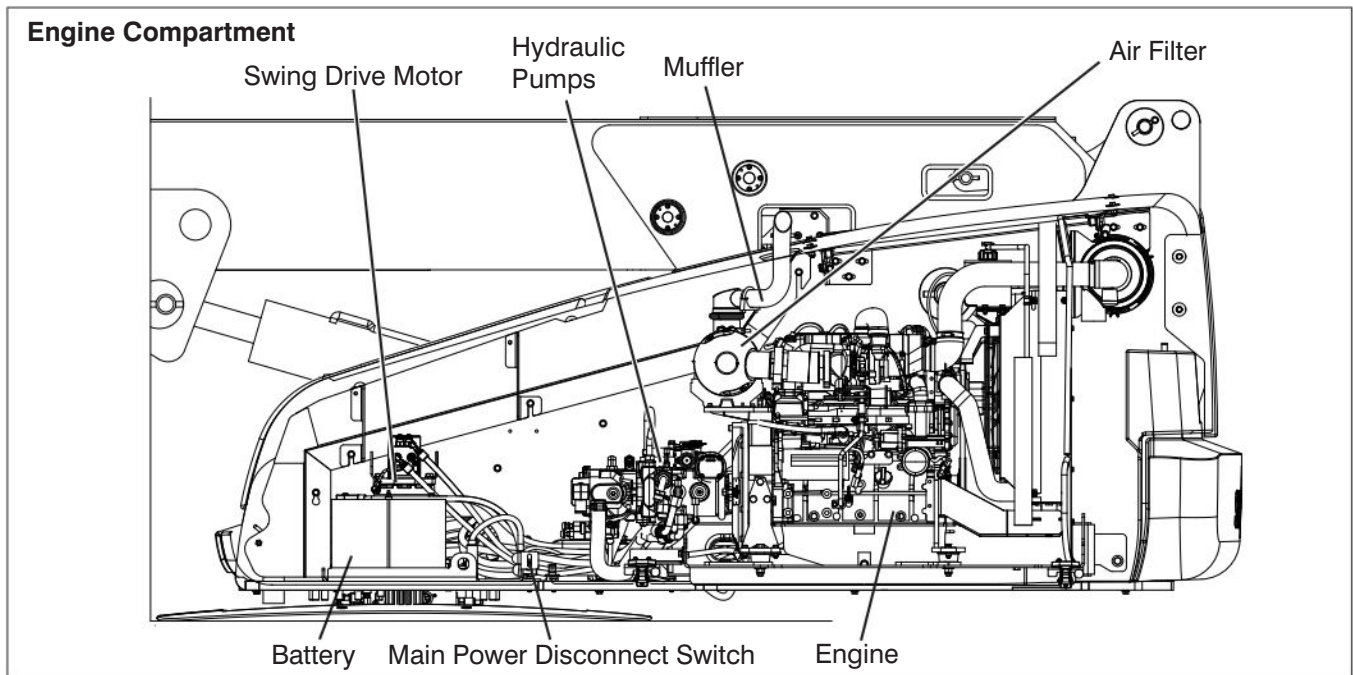

2.3-5 Engine Compartment

- Ensure all compartment latches are secure and in proper working order.
- **Main Power Disconnect Switch**
 - Turn main power disconnect switch to “○” off position.
 - Ensure there are no loose or missing parts and there is no visible damage.
 - Ensure all cables are secure and switch is in proper working condition.
- **Batteries**
 Proper battery condition is essential to good engine performance and operational safety. Improper fluid levels or damaged cables and connections can result in engine component damage and hazardous conditions.

1. Check battery cases for damage.
2. Clean battery terminals and cable ends thoroughly with a terminal cleaning tool or wire brush.
3. Ensure all battery connections are tight.
4. If applicable, check battery fluid level. If plates are not covered by at least 13 mm (1/2”) of solution, add distilled or demineralized water.
5. Replace battery if damaged or incapable of holding a lasting charge.



WARNING

Explosion hazard. Keep flames and sparks away. Do not smoke near batteries.



WARNING

Battery acid is extremely corrosive - Wear proper eye and facial protection as well as appropriate protective clothing. If contact occurs, immediately flush with cold water and seek medical attention.



WARNING

Use original or manufacturer-approved parts and components for the MEWP.

- **Swing Drive Motor**
 - Ensure there are no loose or missing parts and there is no visible damage.
 - Ensure all bolts are properly tightened.
 - Ensure all fittings and hoses are properly tightened and there is no evidence of hydraulic leakage.

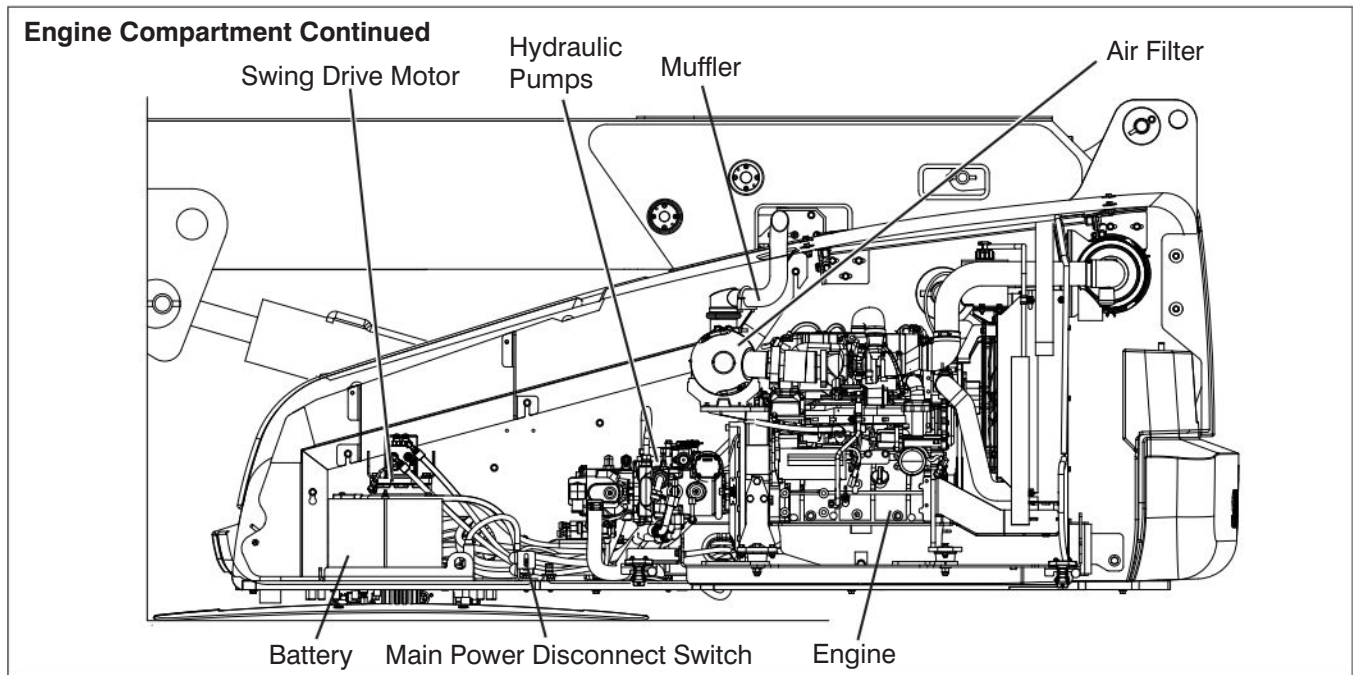

- **Turret Rotation Gear**
 - Ensure there are no loose or missing parts and there is no visible damage.
 - **Rotary Manifold**
 - Ensure all hoses are properly tightened and there is no evidence of hydraulic leakage.
 - **High Pressure Filter**
 - Ensure housing is secure and shows no visible damage or leakage.
 - **Hydraulic Pumps**
 - Ensure there are no loose or missing parts and there is no visible damage.
 - Ensure all bolts are properly tightened.
 - Ensure all fittings and hoses are properly tightened and there is no evidence of hydraulic leakage.
 - **Muffler and Exhaust**
 - Ensure muffler and exhaust system are properly secured, with no evidence of damage.
 - **Engine Pivot Tray**
 - Ensure there are no loose or missing parts and no visible damage to the engine pivot tray. Ensure that each tray-securing bolt is in place.
 - **Engine Oil Level**
 - Maintaining the engine components is essential to good performance and service life of the MEWP.
- ⚠ WARNING**
Beware of hot engine components.
- Check oil level on dipstick**
- Oil level should be in the “safe” zone. Add oil as needed. Refer to [Table 4.2b](#) for recommended oil type.
- **Engine Air Filter**
 - Ensure there are no loose or missing parts and there is no visible damage.
 - **Fuel Leaks**
 - Ensure that there no fuel leaks.
- ⚠ DANGER**
Engine fuels are combustible. Inspect the MEWP in an open, well-ventilated area away from heaters, sparks and flames. Always have an approved fire extinguisher within easy reach.
- Ensure fuel tank, shutoff valve, hoses and fittings show no visible damage and no evidence of fuel leakage.

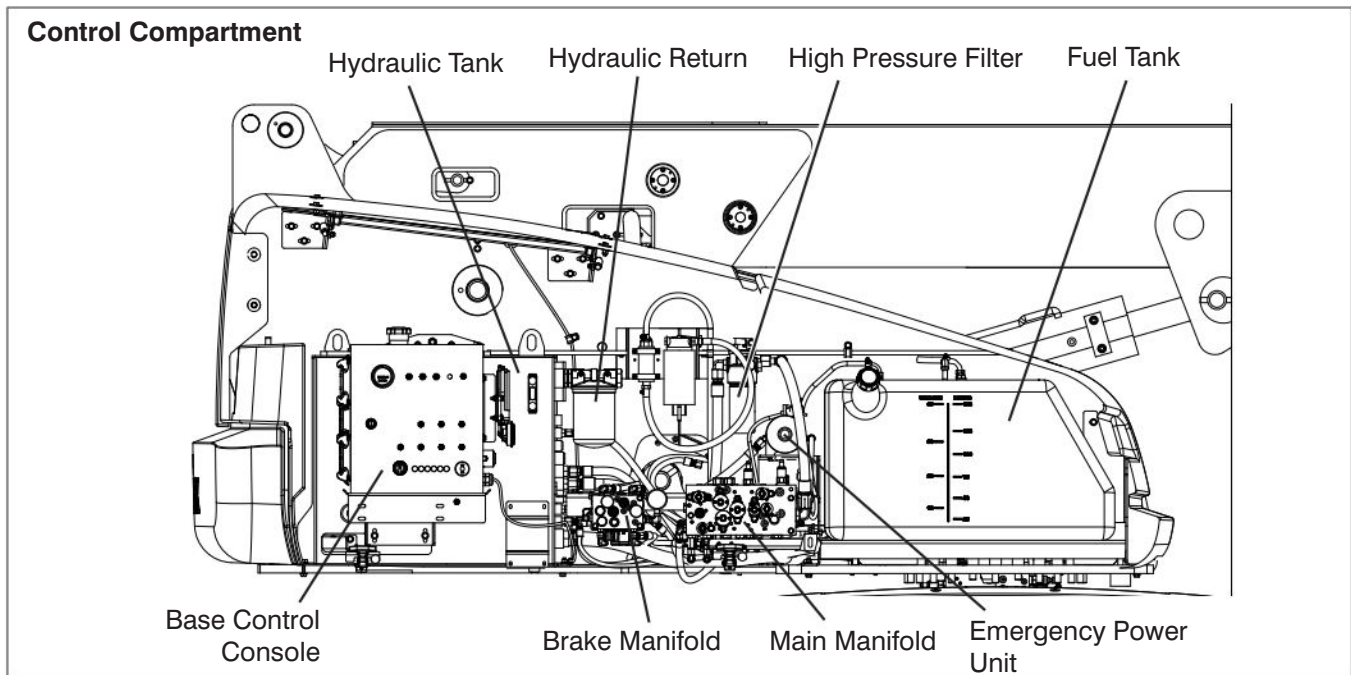

2.3-6 Control Compartment

- Ensure all compartment latches are secure and in proper working order.
- **Base Control Console**
 - Ensure all switches are returned to their neutral positions.
 - Ensure there are no loose or missing parts and there is no visible damage.
- **Hydraulic Tank**
 - Ensure hydraulic filler cap is secure.
 - Ensure tank shows no visible damage and no evidence of hydraulic leakage.
- **Hydraulic Oil**
 - Be sure that the boom is in the stowed position, and then visually inspect the sight gauge located on the side of the hydraulic oil tank.
 - The hydraulic oil level should be between the minimum and maximum marks on the sight glass. Add oil as needed. Refer to [Table 4.2b](#) for recommended oil type.
- **Hydraulic Return Filter**
 - Ensure filter element is secure.
 - Ensure there are no signs of leakage or visible damage.
- **Brake and Main Manifolds**
 - Ensure all fittings and hoses are properly tightened and there is no evidence of hydraulic leakage.
 - Ensure there are no loose wires or missing fasteners.
- **Emergency Power Unit**
 - Ensure there are no loose or missing parts and there is no visible damage.
 - Ensure there are no loose wires or missing fasteners.
 - Ensure all fittings and hoses are properly tightened and there is no evidence of hydraulic leakage.

FAMILIARIZATION

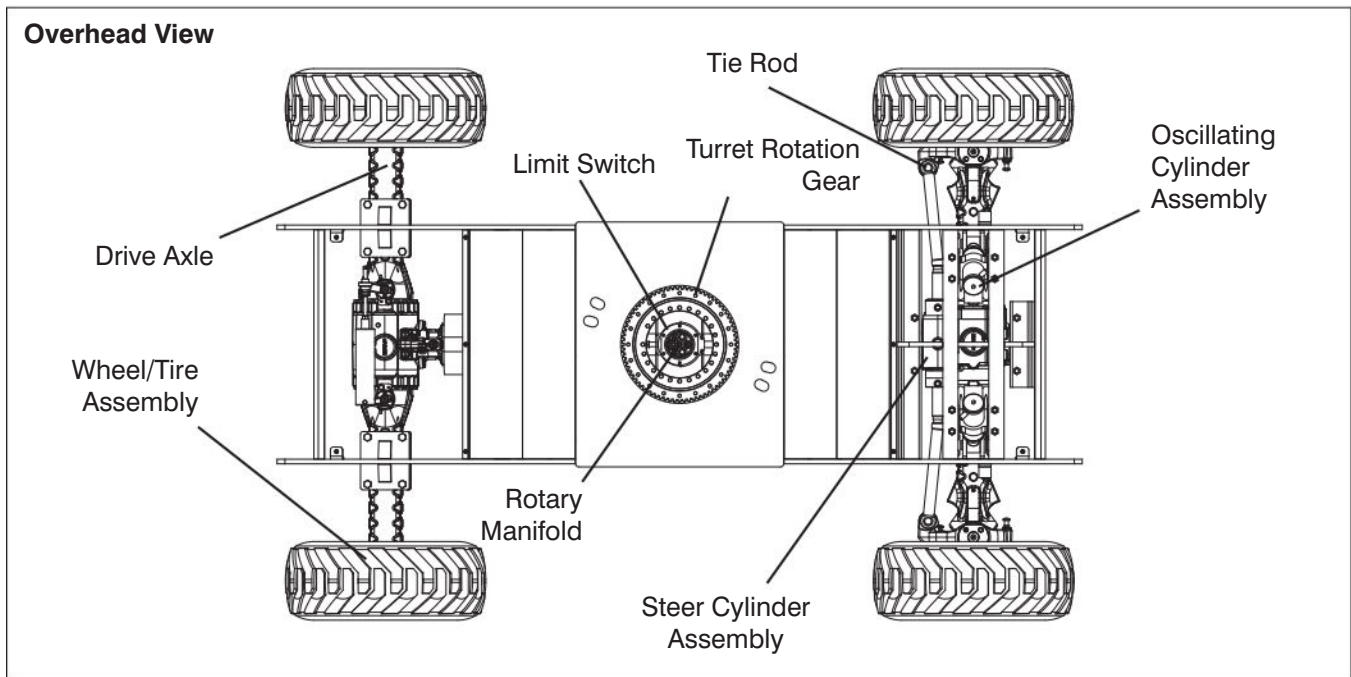

- Fuel Tank

IMPORTANT

Before using your MEWP ensure there is enough fuel for expected use.

- Ensure fuel filler cap is secure.
- Ensure tank shows no visible damage and no evidence of fuel leakage.

- Fuel Leaks

- Ensure that there no fuel leaks.



DANGER

Engine fuels are combustible. Inspect the MEWP in an open, well-ventilated area away from heaters, sparks and flames. Always have an approved fire extinguisher within easy reach.

- Ensure fuel tank, shutoff valve, hoses and fittings show no visible damage and no evidence of fuel leakage.

2.3-7 Base

- Turret Transportation Lock

- Ensure turret transportation lock is unlocked, there are no loose or missing parts and there is no visible damage.

- Drive Axle

- Ensure drive axle is properly secured, there are no loose or missing parts, all fittings and hoses are properly tightened and there is no evidence of hydraulic leakage.

- Oscillating Cylinder Assembly

- Ensure oscillating cylinder assembly is properly secured, there are no loose or missing parts, all fittings and hoses are properly tightened and there is no evidence of hydraulic leakage.

NOTE

Oscillating axle is locked when MEWP is in work mode. Refer to [Diagram 3.2. Axle Oscillation Diagram](#).

- Steer Cylinder Assembly

- Ensure steer cylinder assembly is properly secured, there are no loose or missing parts, all fittings and hoses are properly tightened and there is no evidence of hydraulic leakage.

- Tie Rod

- Ensure there are no loose or missing parts, tie rod end studs are locked and there is no visible damage.

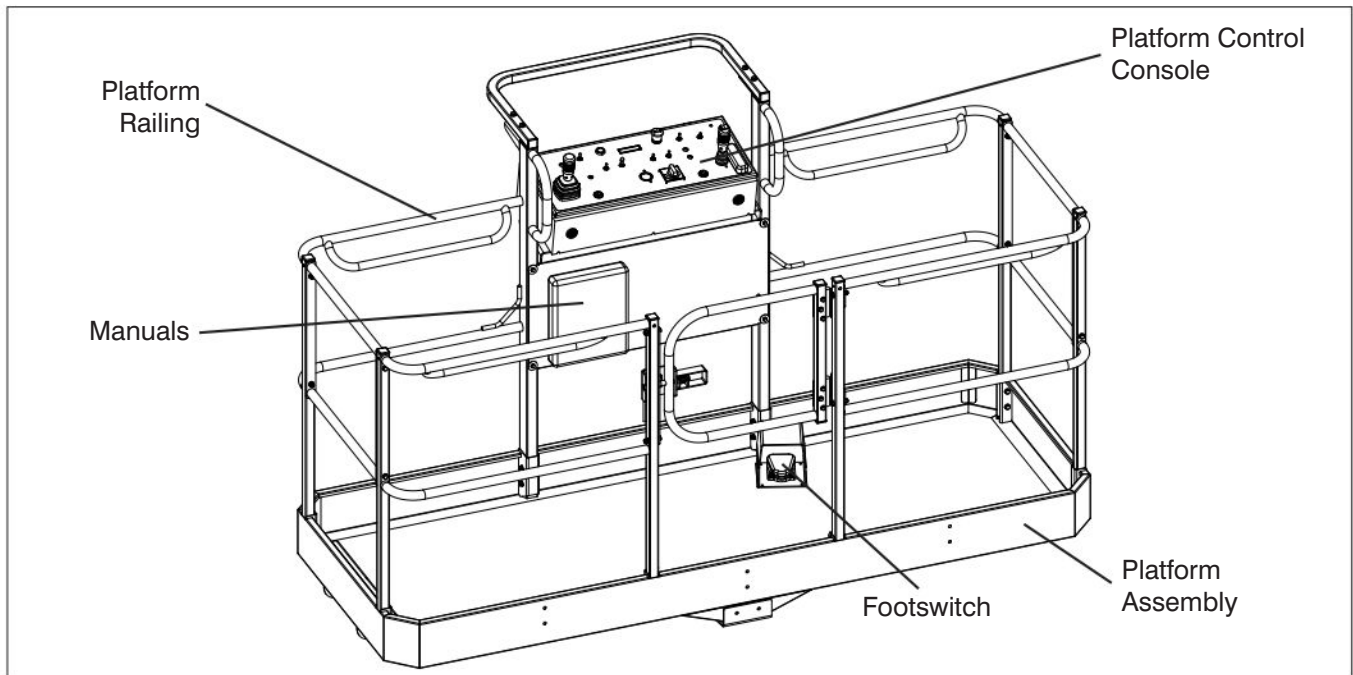

- **Wheel/Tire Assembly**
The MEWP is equipped with foam-filled tires. Tire and/or wheel failure could result in an MEWP tip over. Component damage may also result if problems are not discovered and repaired in a timely fashion.
- Check all tire treads and sidewalls for cuts, cracks, punctures and unusual wear.
- Check each wheel for damage and cracked welds.
- Check each lug nut for proper torque to ensure none are loose.

Refer to [Table 4.4](#) for wheel/tire specifications.

! WARNING

Intermixing tires of different types or using tires of types other than those originally supplied with this equipment can adversely affect stability. Therefore, replace tires only with the exact Skyjack-approved type. Failure to operate with matched approved tires in good condition may result in death or serious injury.

2.3-8 Manuals

Ensure a copy of operating manual, EC declaration and other important documents are enclosed in manual storage box.

- Check to be sure manual storage box is present and in good condition.
- Ensure manuals are legible and in good condition.
- Always return manuals to the manual storage box after use.

2.3-9 Platform Assembly

- Ensure there are no loose or missing parts and there is no visible damage.
- Ensure all fasteners are securely in place.
- Ensure all railings are properly positioned and secured.
- Ensure gate is in good working order.
- Ensure footswitch is in good working order and has not been modified, disabled or blocked.

2.3-10 Platform Control Console

- Ensure all switches/controllers are returned to neutral and are properly secured.
- Ensure there are no loose or missing parts and there is no visible damage.

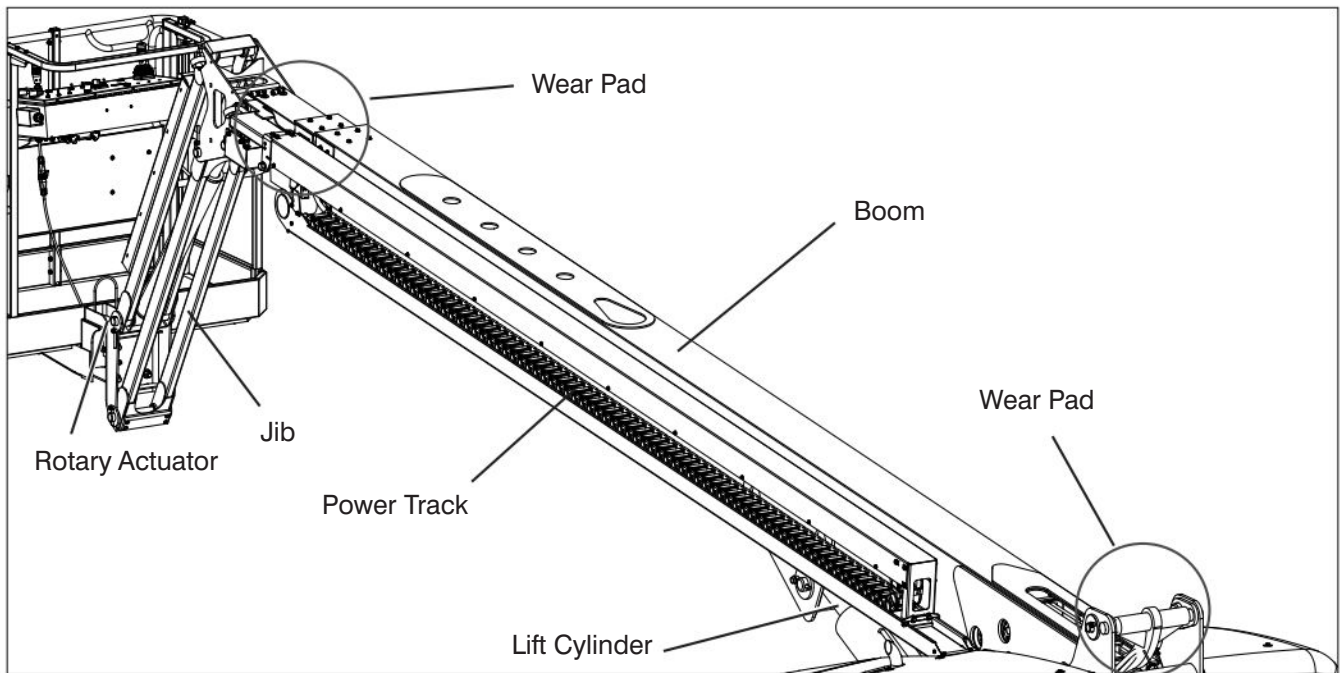

2.3-11 Rotary Actuator

- Ensure there are no loose or missing parts and there is no visible damage.
- Ensure all bolts and pins are properly tightened.
- Ensure all hoses are properly tightened and there is no evidence of hydraulic leakage.

2.3-12 Load Cell

- Ensure there are no loose or missing parts and there is no visible damage.
- Ensure all bolts are properly tightened.
- Ensure all cables are secure and are in proper working condition.
- Ensure debris is not lodged between the platform and boom adaptor.

2.3-13 Jib

- Ensure there are no loose or missing parts and there is no visible damage.
- Ensure all bolts and pins are properly tightened.
- Ensure all hoses are properly tightened and there is no evidence of hydraulic leakage.

2.3-14 Boom

- Ensure there are no loose or missing parts and there is no visible damage.
- Ensure all bolts and pins are properly tightened.
- Ensure there are no visible cracks in welds or structure and there are no signs of deformation.
- Ensure all hoses are properly tightened and there is no evidence of hydraulic leakage.
- **Cylinders**
 - Ensure all cylinders are properly secured and there is no evidence of leakage.
- **Wear Pads**
 - Ensure all bolts are tight, there is no visible damage to the wear pads and that no parts are missing.
- **Hoses**
 - Ensure all hoses are properly tightened and there is no evidence of hydraulic leakage.
- **Power Track**
 - Ensure there are no loose or missing parts and there is no visible damage.

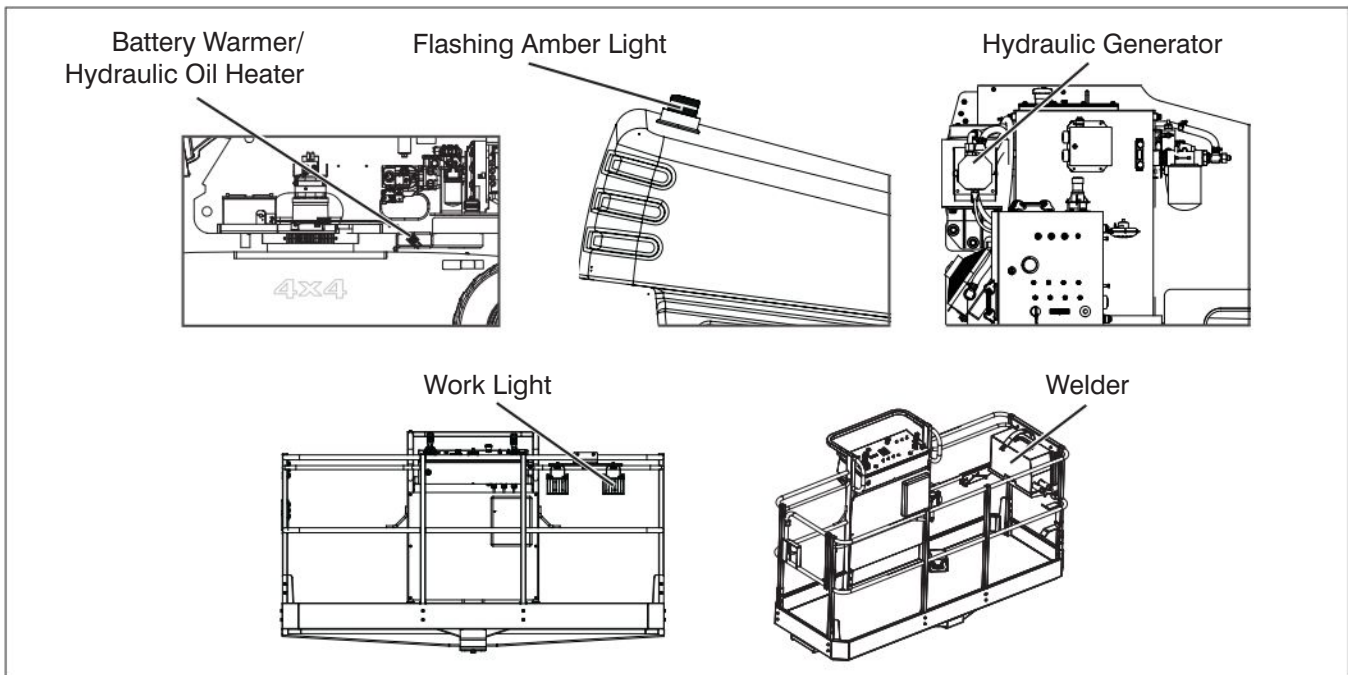

- **Cables**
 - Ensure there are no loose or missing parts with no signs of visible damage.
 - Ensure that nuts are not loose and are locked together.
 - Ensure that there are no gaps between springs (see Figure 2-7). If there are gaps, tighten nuts to remove gaps and then add another half turn more.
- **Battery Warmer/Hydraulic Oil Heater (If Equipped)**
 - Ensure battery warmer/hydraulic oil heater cord is properly secured with no signs of visible damage and hydraulic leakage.
- **Welder (If Equipped)**
 - Ensure welder and welder tray are properly secured.
 - Ensure there are no loose or missing parts and there is no visible damage.
 - Ensure there are no loose wires or missing fasteners.

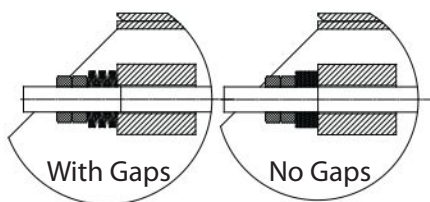
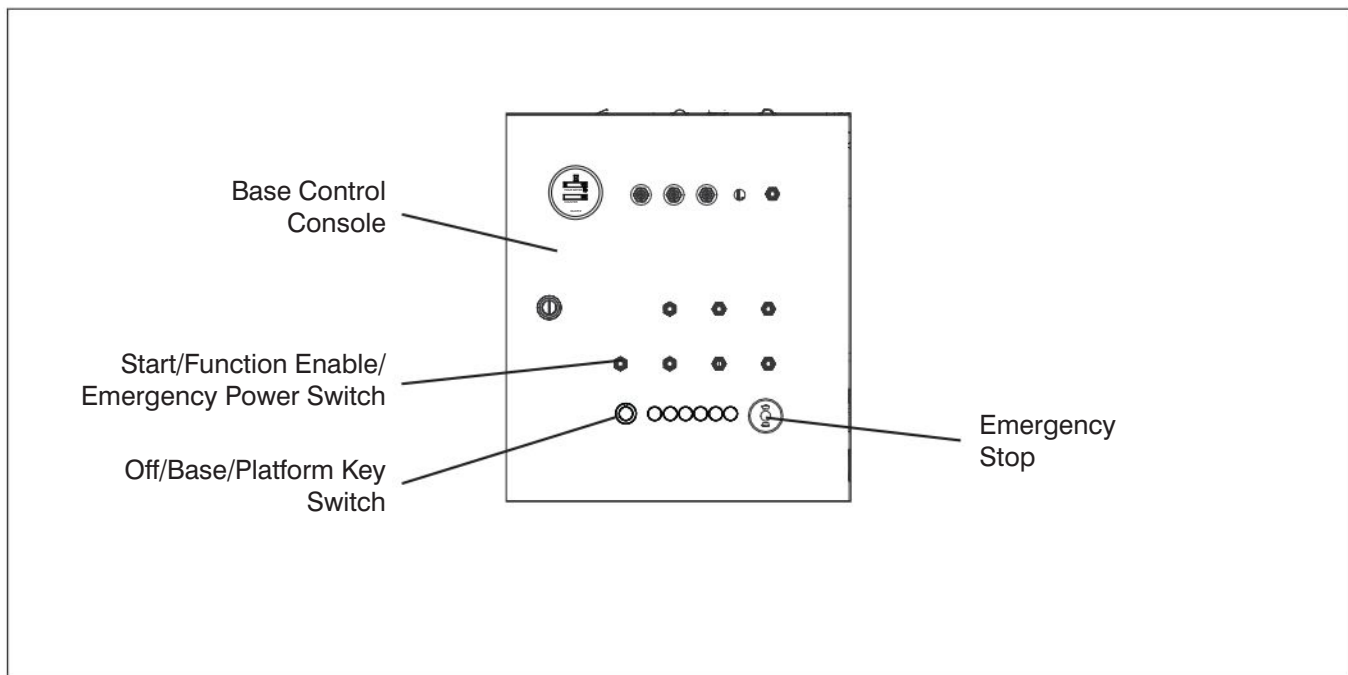

Figure 2-7. Springs

2.3-15 Optional Equipment/Attachments

- **Hydraulic Generator (If Equipped)**
 - Ensure there are no loose or missing parts with no signs of visible damage.
 - Ensure all hoses are properly tightened and there is no evidence of hydraulic leakage.
- **Work Light (If Equipped)**
 - Ensure lamps are properly secured with no signs of visible damage.
 - Ensure mounting bracket is properly secured.
 - Ensure there are no loose wires or missing fasteners.
- **Flashing Amber Light (If Equipped)**
 - Ensure lamp is properly secured with no signs of visible damage.



2.4 Function Tests

Function tests are designed to discover any malfunctions before MEWP is put into service. The operator must understand and follow step-by-step instructions to test all MEWP functions.

IMPORTANT

Never use a malfunctioning MEWP. If malfunctions are discovered, MEWP must be tagged and placed out of service. Repairs to MEWP may only be made by a qualified service technician.

After repairs are completed, operator must perform a pre-operation inspection and a series of function tests again before putting MEWP into service.

Prior to performing function tests, be sure to read and understand [Section 3.8 - Start Operation](#).

NOTE

All-function motion alarm should sound while operating any boom and drive function.

2.4-1 Test Main Power Disconnect Switch





- In engine compartment, turn main power disconnect switch to “O” off position.
Result: MEWP functions should not operate.

- In engine compartment, turn main power disconnect switch to “I” on position.



NOTE

Close all cowlings before proceeding to next item.

2.4-2 Base Control Console

- On platform control console, pull out “” emergency stop button.
- On base control console, pull out “” emergency stop button.
- Turn off/base/platform key switch to “” base position.
- Start engine by selecting “” start position from start/function enable/emergency power switch.

• Test Emergency Stop

- Push in “” emergency stop button.
Result: Engine should shut down and MEWP functions should not operate.
- Pull out “” emergency stop button and restart engine.

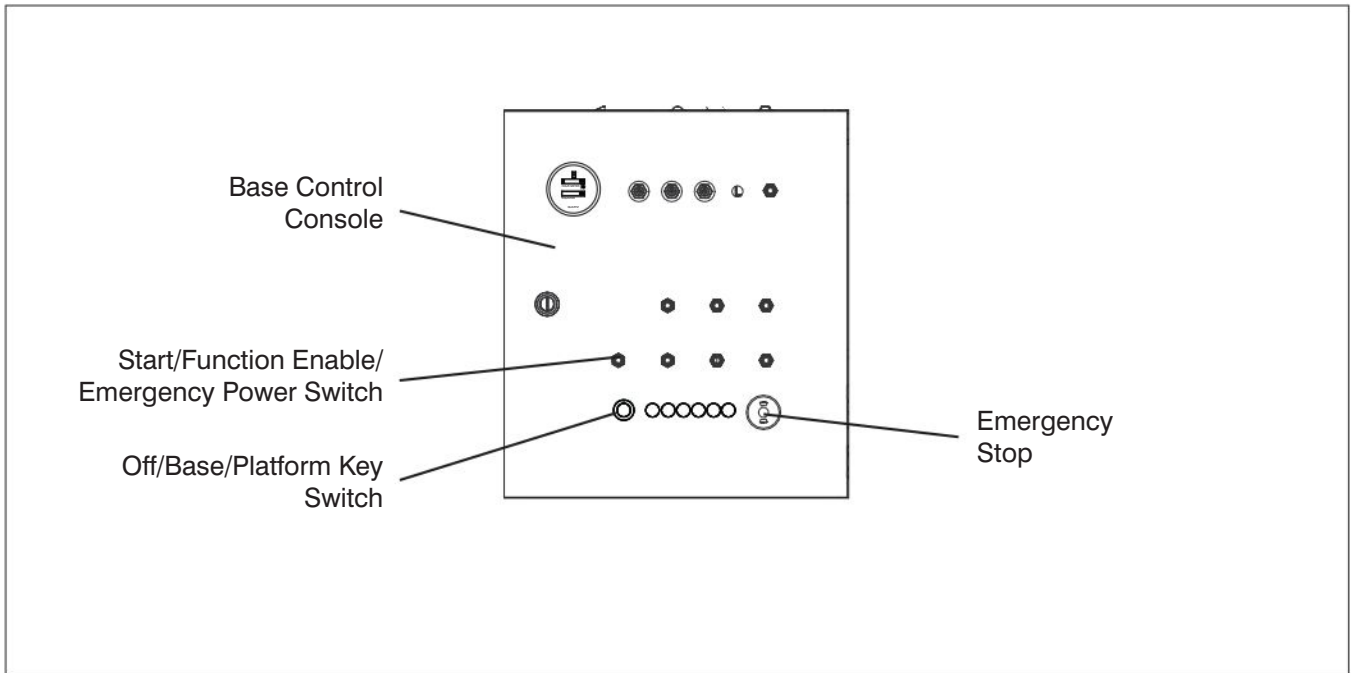



- Test Start/Function Enable/Emergency Power Switch and All Boom Functions





WARNING

Ensure that there are no personnel or obstructions in test area and there is sufficient room for boom to swing.



1. Ensure “” emergency stop button is pulled out.
2. Start engine.
3. Do not hold “” start/function enable/emergency power switch in function enable position. Attempt to activate each boom and platform switch.
Result: All boom and platform functions should not operate.
4. Hold “” start/function enable/emergency power switch in function enable position and activate each boom and platform function.
Result: Engine speed increases from idle to intermediate. All boom and platform functions should operate as selected.

- Test Platform Self-leveling

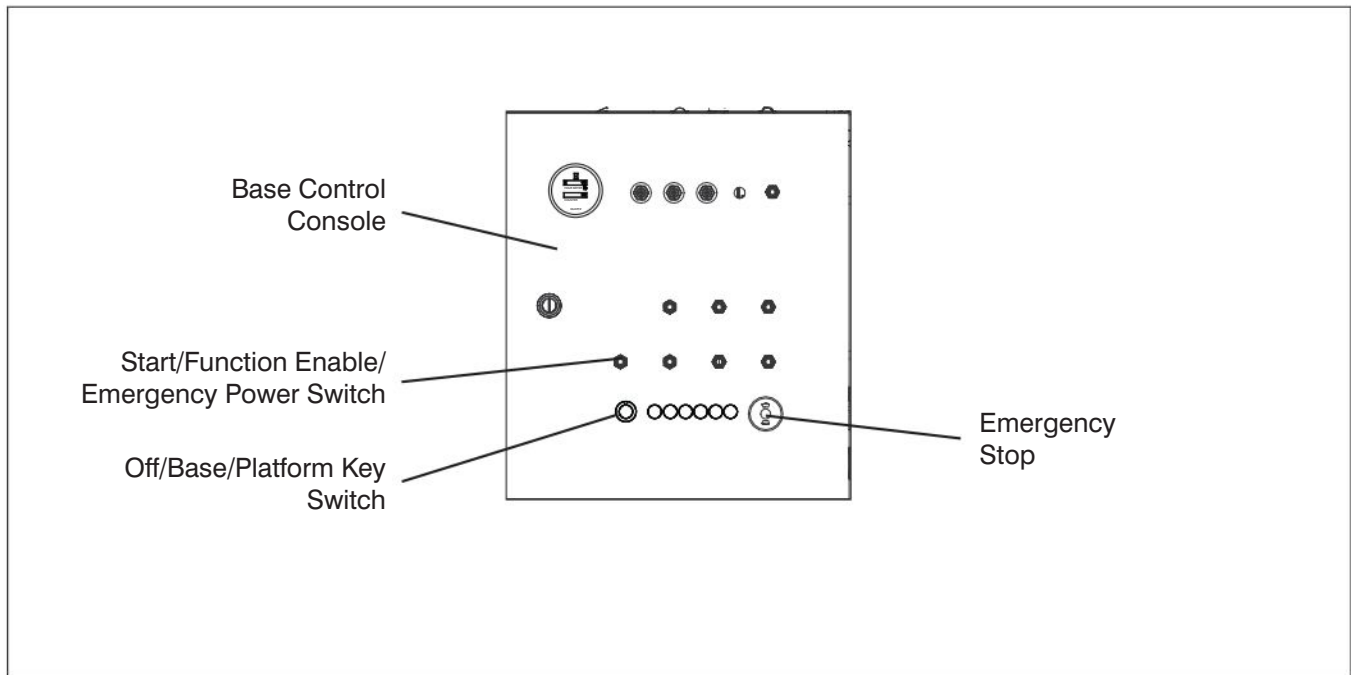
1. Lower boom to stowed position.
2. Adjust platform to a level position using platform leveling switch.
3. Raise “” and lower “” main boom through a full cycle.
Result: Platform should remain level at all time.



• **Test Emergency Power**

1. On base control console, push in “” emergency stop button to turn engine off.
2. On platform control console, push in “” emergency stop button.







CAUTION

When operating on auxiliary power, do not operate more than one function at a time to avoid overloading 12-Volt auxiliary pump motor.

NOTE



To conserve battery power, test each function through a partial cycle.

3. On base control console, pull out “” emergency stop button.

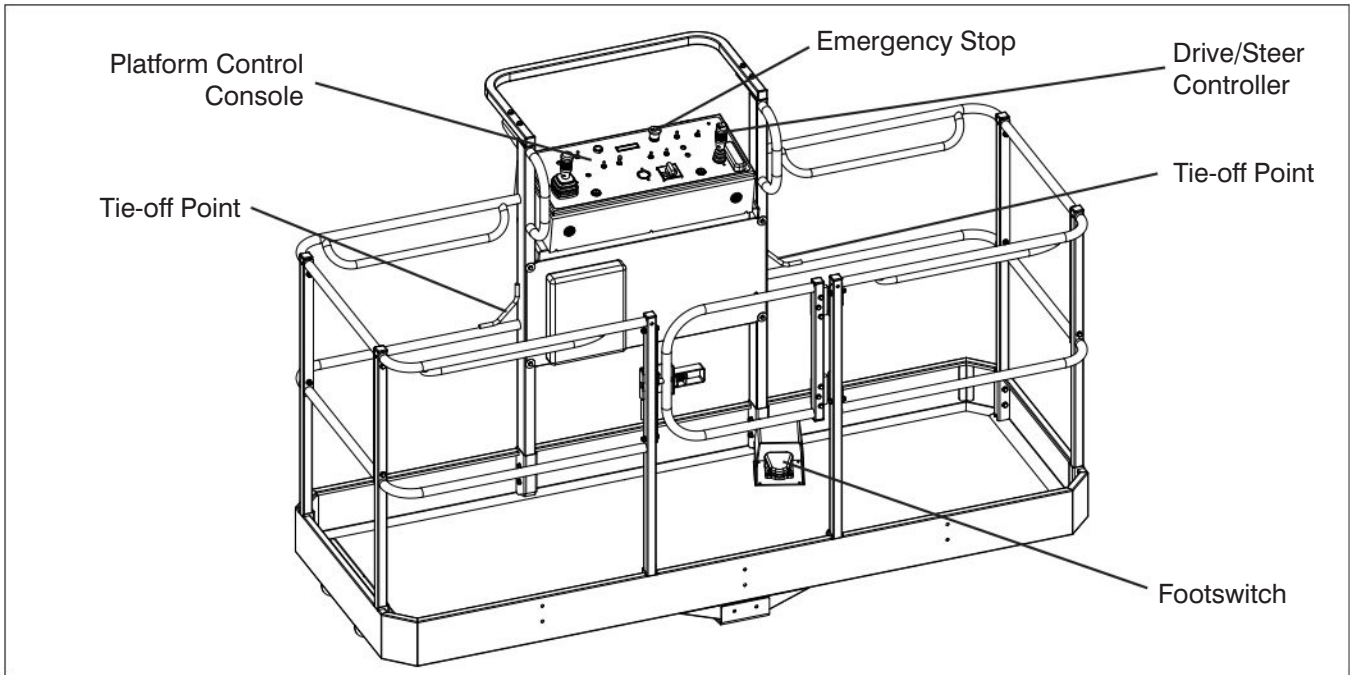
4. On base control console, turn off/base/platform key switch to “” platform position.
5. Select “” emergency power position from start/function enable/emergency power switch and activate each boom function.
Result: All selected functions should operate.
6. Turn off/base/platform key switch to “” base position.
7. Select “” emergency power position from start/function enable/emergency power switch and activate each boom function.
Result: All selected functions should operate.



• **Test Off/Base/Platform Switch**



1. Ensure both “” emergency stop button is pulled out.
2. Start engine.
3. On base control console, turn off/base/platform key switch to “” off position.
Result: Engine should shut down and MEWP functions should not operate.
4. On base control console, turn off/base/platform key switch to “” platform position.



WARNING

Ensure that you maintain three points of contact to mount/dismount platform.

5. Enter platform and close gate.
6. On platform control console, select “” on position from engine start/on/off switch.

7. Select “” start position from engine start/on/off switch until engine starts.
8. Dismount from platform.
9. On base control console, attempt to activate each boom and platform switch while holding start/function enable/emergency power switch in function enable position.
Result: All boom and platform functions should not operate while holding start/function enable/emergency power switch in function enable position.
10. Push in “” emergency stop button to turn engine off.
11. Pull out “” emergency stop button.

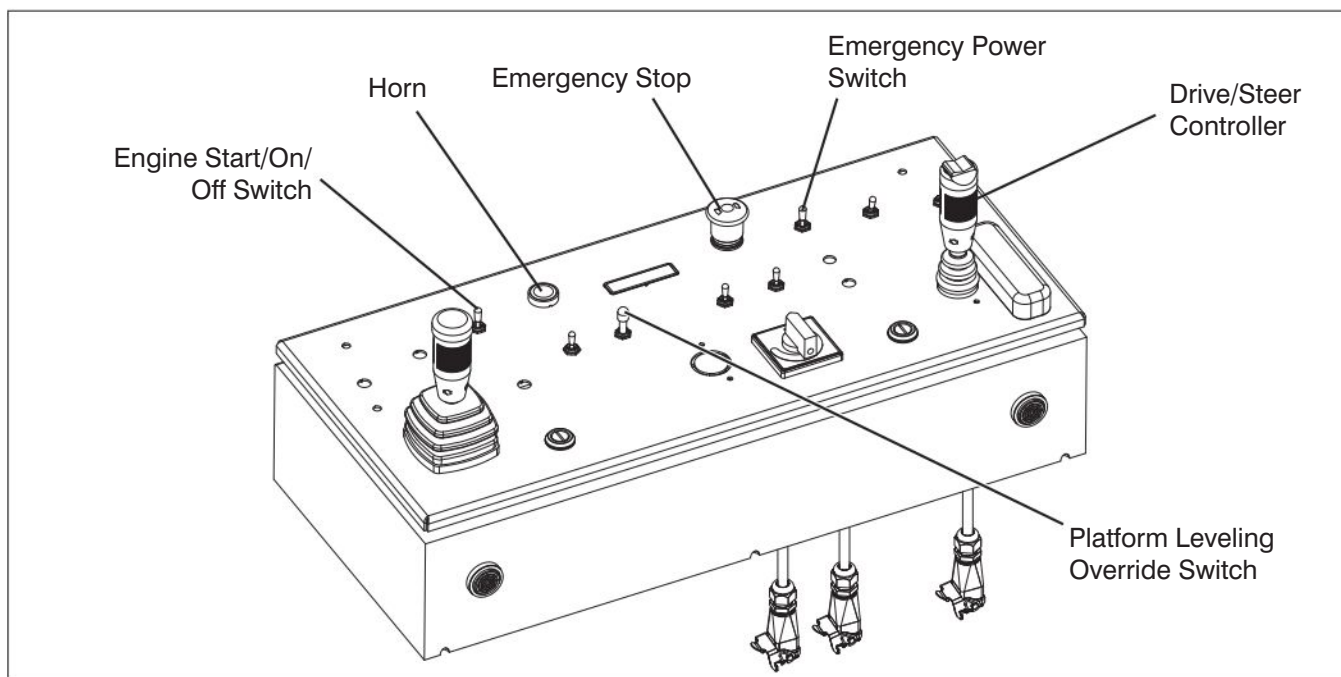

2.4-3 Platform Control Console



WARNING

Ensure that you maintain three points of contact to mount/dismount platform.

1. Enter platform and close gate.



WARNING



DO NOT operate any control on platform control console without proper fall protection secured to designated location in platform. Failure to avoid this hazard could result in death or serious injury!



WARNING



Ensure that there are no personnel or obstructions in test area and that there is sufficient room for boom to swing.

• Test Load Sensing System

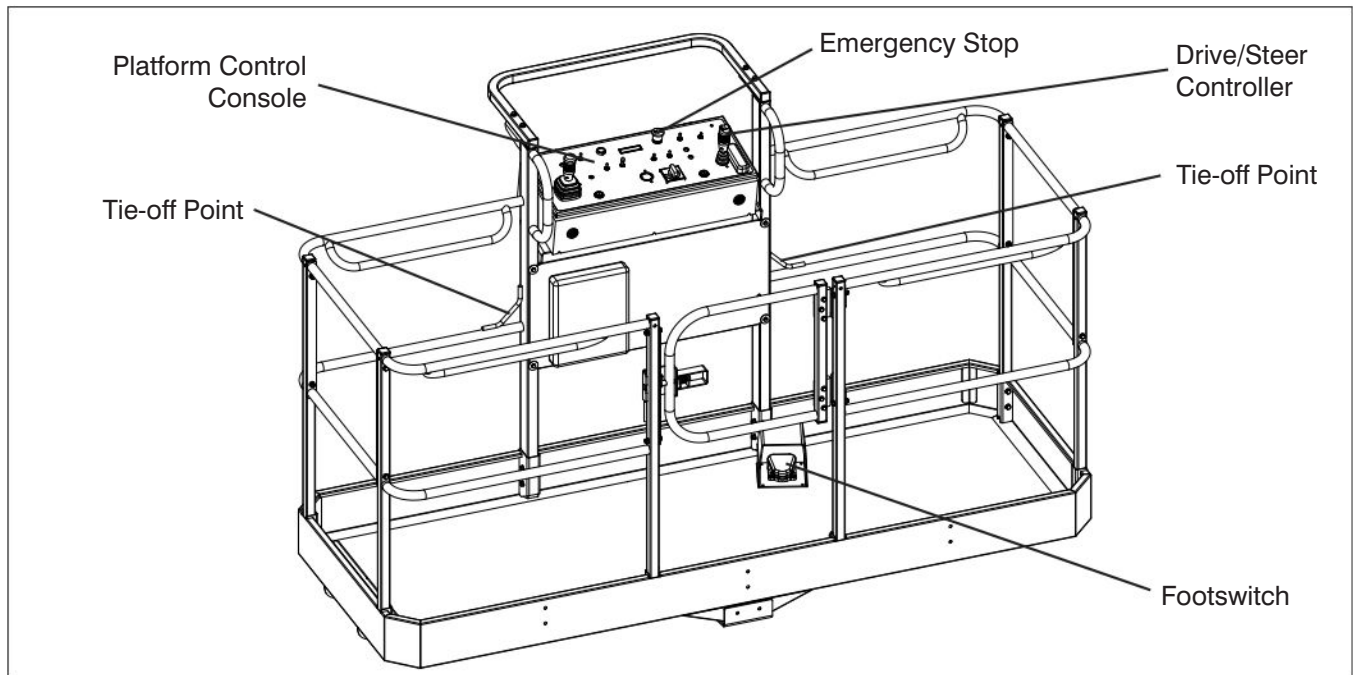
1. Push in “” emergency stop button.
2. Pull out “” emergency stop button.
Result: After four seconds of time elapses, the red light and audible alarm pulse two times. This indicates the system is active and there are no faults.





- **Test Footswitch**

1. Pull out “” emergency stop button.
2. Ensure engine start/on/off switch is in “” on position.
3. Do not start engine.
4. Select generator on/off switch to off position (if equipped).
5. Depress and hold footswitch and attempt to start engine by selecting “” start position from engine start/on/off switch.
Result: Engine should not start.
6. Without depressing footswitch, try to start engine.
Result: Engine should start.
7. With engine running and without depressing footswitch, test each boom and platform function.
Result: MEWP functions should not operate.

NOTE

A 15-second anti-tiedown feature deactivates footswitch when operator depresses it for 15 seconds without activating any function.

- **Test Engine Start/On/Off Switch**



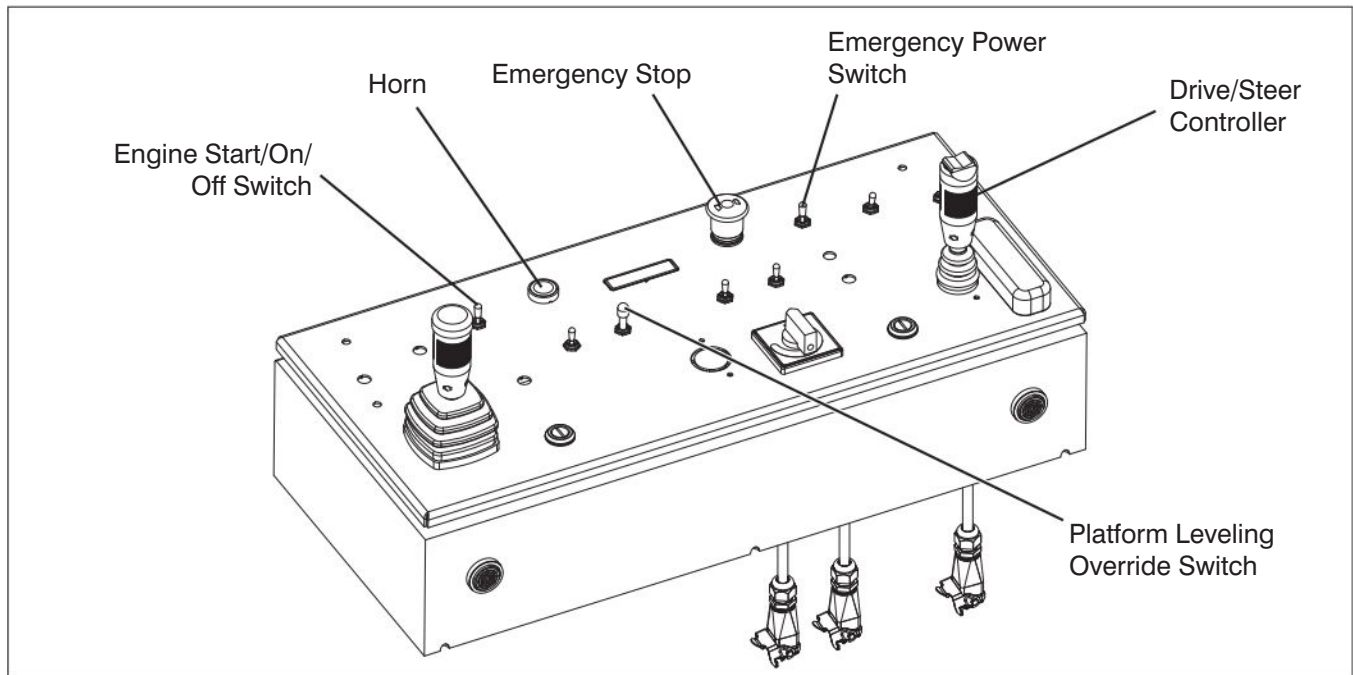

1. Ensure engine is running.
2. Select “” off position from engine start/on/off switch.
Result: Engine should shut down and platform control console is disabled.
3. Select “” on position from engine start/on/off switch.
Result: Platform control console is enabled.
4. Start engine by selecting “” start position from engine start/on/off switch.





- **Test Emergency Stop**

1. Ensure engine is running.
2. Push in “” emergency stop button.
Result: Engine should shut down and MEWP functions should not operate.

- **Test Steering**

1. Pull out “” emergency stop button.
2. Start engine by selecting “” start position from engine start/on/off switch.
3. Depress and hold footswitch.
4. Press rocker switch on top of drive/steer controller to “” left and “” right.
Result: Steer wheels should turn left and right.

- **Test Driving Function**

1. Ensure path of intended motion is clear.
2. Ensure boom is in stowed position and fly boom fully retracted.
3. Depress and hold footswitch.
4. Slowly move drive/steer controller in “” forward or “” reverse direction until MEWP begins to move, and then return handle to center position.
Result: MEWP should move in forward or reverse direction, and then come to a stop.

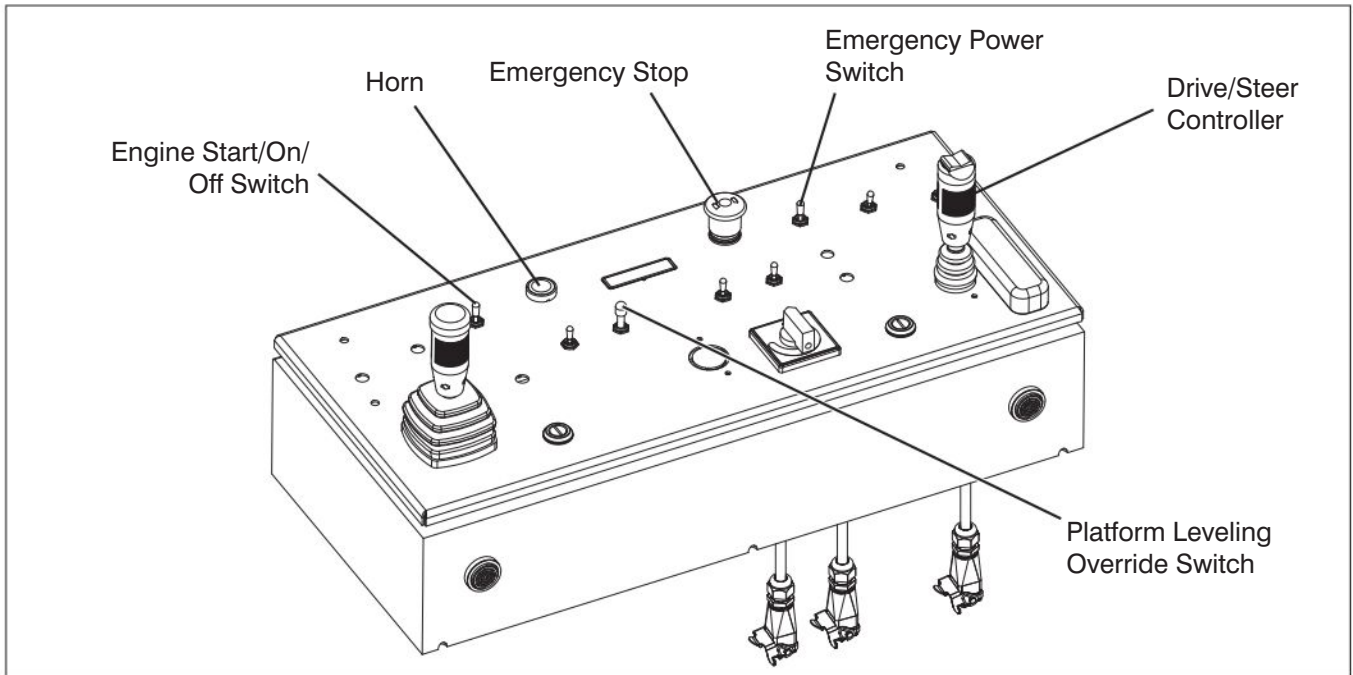

• Test Driving Speed

1. Depress and hold footswitch.
2. Raise “” main boom approximately 4 m (14 ft.) and then slowly move drive/steer controller to full drive position.
Result: The maximum achievable drive speed should be significantly less than stowed drive speed.
3. Lower boom to stowed position.
4. Extend “” fly boom approximately 30 cm (12 inch.) and then slowly move drive/steer controller to full drive position.
Result: The maximum achievable drive speed should be significantly less than stowed drive speed.

• Test Emergency Power



CAUTION

When operating on auxiliary power, do not operate more than one function at a time to avoid overloading 12-Volt auxiliary pump motor.

NOTE

To conserve battery power, test each function through a partial cycle.

1. On platform control console, push in “” emergency stop button to turn engine off.
2. Pull out “” emergency stop button.
3. Select “” on position from engine start/on/off switch.
4. Depress and hold footswitch.
5. Select “” from emergency power unit switch and activate each function control handle or switch.
Result: All boom and steer functions should operate. Drive functions should not operate.

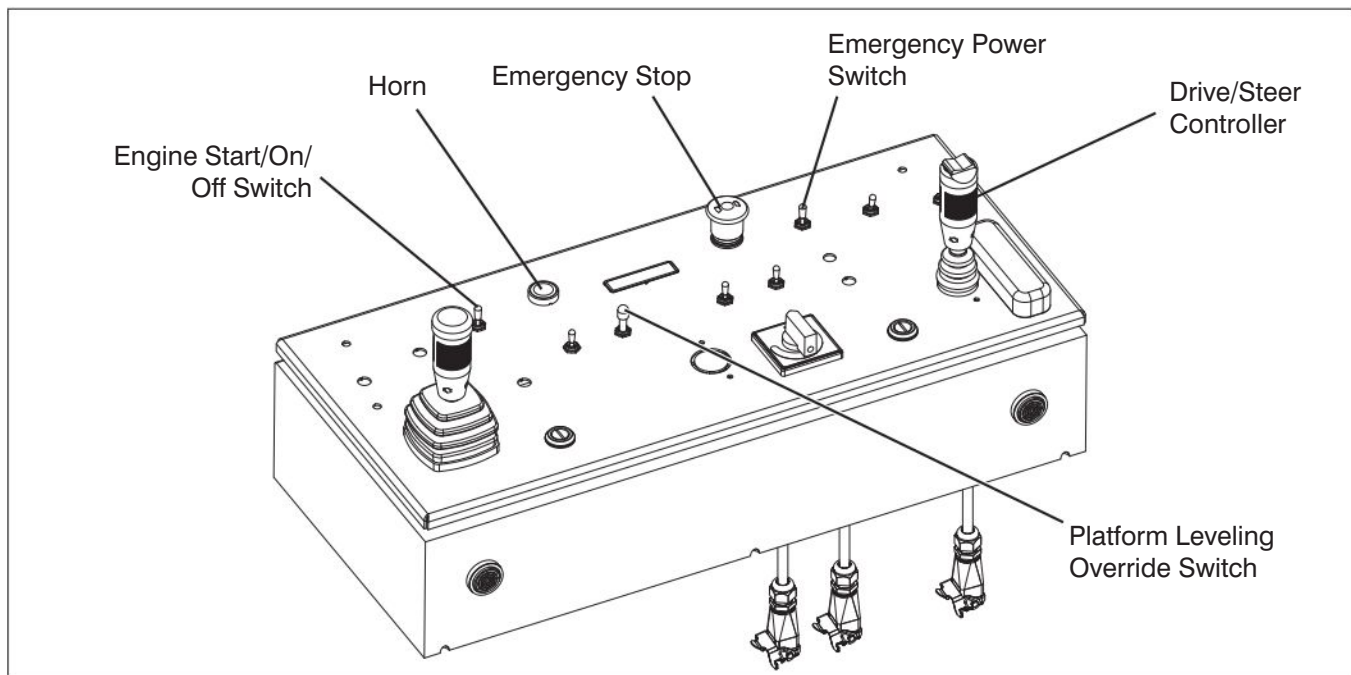



- Test Horn

1. Push “” horn pushbutton.
Result: Horn should sound.



- Test Brakes

**WARNING**

Brakes will engage instantly when you release footswitch, causing MEWP to stop immediately.

1. Move MEWP to a firm level surface to ensure similar traction on left and right.
2. Ensure boom is in stowed position.
3. Depress and hold footswitch and drive MEWP first “” forward then “” reverse at full speed.
4. Remove your foot from footswitch.
Result: MEWP should come to an instant and abrupt stop. If MEWP does not stop immediately, or if MEWP pulls to one side while stopping, do not operate MEWP until brake adjustments have been checked.

- Test Manual Platform Leveling

1. Depress and hold footswitch.
2. On platform leveling override switch, lift and move switch to “” upward position to tilt platform up or “” lift and move switch to downward position to tilt platform down.
Result: Platform should tilt up or down.

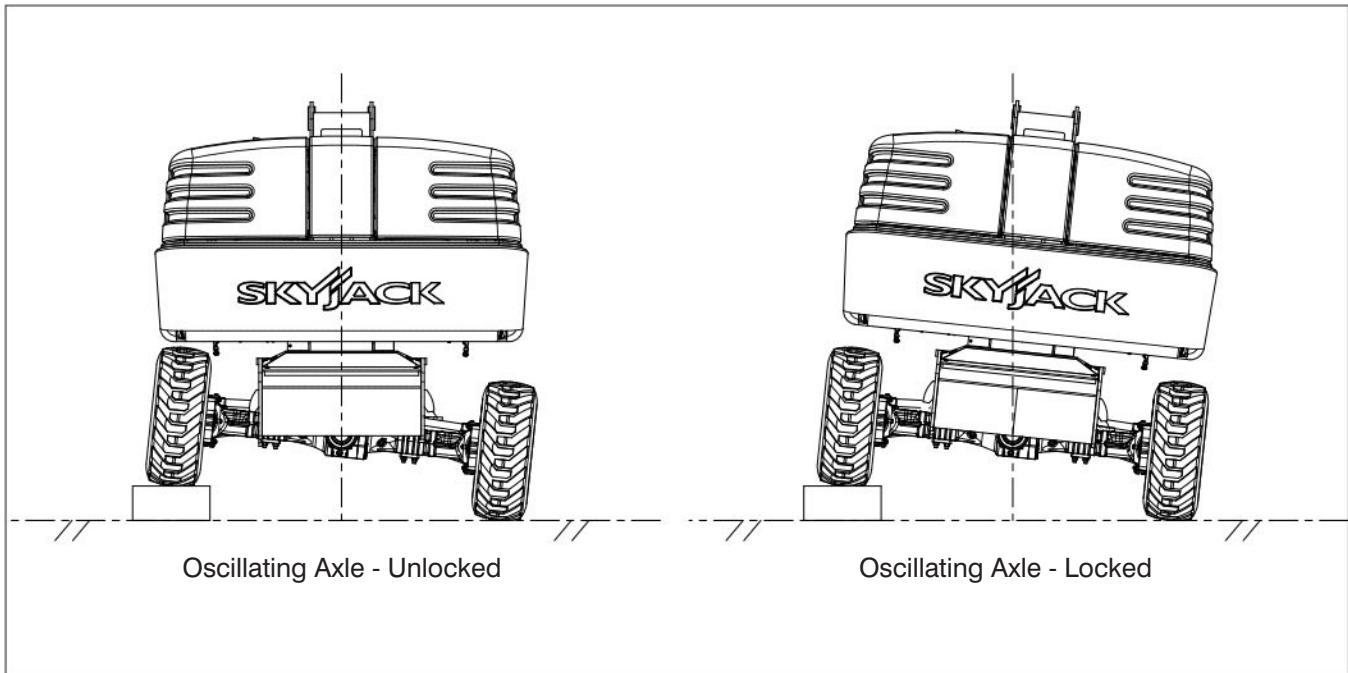

- Test Oscillating Axles



WARNING

DO NOT operate any control on platform control console without proper fall protection secured to designated location in platform. Failure to avoid this hazard could result in death or serious injury!

1. Extend fly boom 30 cm (12 in.) while on a firm level ground.
Result: The steer axles should be locked.
2. Drive one of the steer tires up onto a 15 cm (6 in.) block or curb.
Result: An appropriate tilt of the MEWP chassis should occur.
3. Retract fly boom while in tilt position.
Result: The steer axles should unlock and the MEWP chassis should level itself to ground.

- Test Cables

NOTE

Cables have to be tested daily.

1. Raise the main boom to approximately horizontal.
2. Extend and retract the boom sections.
Result: There should be no delay in the movement of the fly boom section.

2.5 Winching and Towing Procedure

This section provides the operator with the Winching and Towing procedure, which includes instructions on how to manually release the brakes.



WARNING

Ensure boom is in stowed position before winching or towing. Sudden motion could cause MEWP to become unstable. Death or serious injury could result.



WARNING

In emergency situations where MEWP functions are not available and lowering is impeded by an obstacle, utmost care must be taken to move MEWP far enough to clear obstacle. In such cases, operation must be extremely smooth with no sudden movements and must not exceed a speed of 50 mm/sec (2 in./sec).



WARNING

When pushing, winching or towing, do not exceed 3.2 km/h (2 mph).



WARNING

Do not winch or tow MEWP on grade steeper than 50% (4WD).



WARNING

Do not winch or tow MEWP onto a slope, or brake the towing vehicle rapidly. Do not pull MEWP down an incline towards a winch.

1. Before winching or towing MEWP, fully retract, lower and position boom over rear drive wheels in line with direction of travel.
2. Manually release brakes (refer to [Section 2.5-1](#)).
3. Remove wheel chocks or blocks, and then winch or tow MEWP to desired location.

4. Position MEWP on a firm and level surface.
5. Chock or block wheels to prevent MEWP from rolling.
6. Apply brakes by pulling out black brake auto reset valve.

NOTE

Brakes automatically apply when platform controls are engaged.



WARNING

Brakes must be applied immediately after reaching desired location.

2.5-1 To Release Brakes Manually

Brakes must be manually disengaged for winching or towing.



WARNING

Do not manually disengage brakes if MEWP is on a slope.

1. Ensure MEWP is on level ground. Chock or block wheels to keep MEWP from rolling.
2. Turn main power disconnect switch to “O” off position.



CAUTION

Do not use hydraulic power with brake disengaged.

3. Locate the bypass valve on the inboard side of the drive pump. Bypass the drive pump by loosening the valve stem (item 1 - marked with yellow paint) two revolutions counterclockwise.

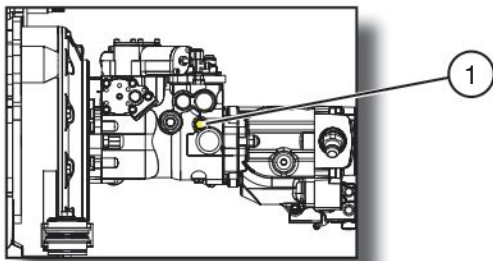

Figure 2-8. Drive Bypass Valve



CAUTION

Do not release brakes before disengaging drive motor!

4. Push in black brake valve plunger (item 3).

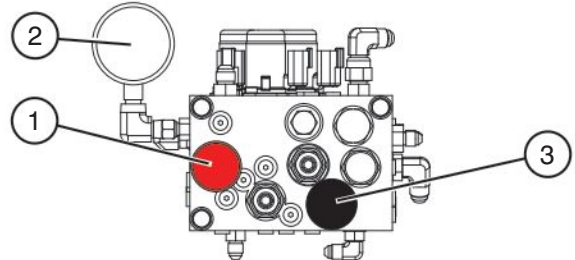

Figure 2-9. Brake Manifold

5. Actuate red hand pump (item 1) slowly by moving knob in and out until pressure gauge (item 2) registers 2068 - 2965 kPa (300 - 430 psi). Brake is now released.



WARNING

Brakes must be applied immediately after reaching desired location. Refer to Section 2.5 on how to reengage brakes.

2.6 Emergency Lowering Procedures





This section guides the operator on how to use emergency lowering system. This system allows platform lowering in the event of an emergency or engine malfunction.





WARNING

Do not operate emergency power unit if platform capacity is exceeded. The emergency power unit may be used to release the platform from an obstruction that has triggered an overload condition.

At Base Control Console:

1. Ensure engine is off.
2. Pull out “” emergency stop button.
3. Select either “” base position or “” platform position from key switch.
4. Select “” emergency power position from start/function enable/emergency power switch and activate desired boom function.

At Platform Control Console:

1. Ensure engine is off.
2. Pull out “” emergency stop button.
3. Select “” on position from engine start/on/off switch.
4. Depress and hold footswitch.
5. Select “” from emergency power unit switch and activate desired boom function.

NOTE

If platform is overloaded in work mode, emergency lowering is only available from base controls.

3.0 Operation

This section provides the necessary information needed to operate the MEWP. It is important that the user reads and understands this section before operating the MEWP.

3.1 General

In order for this MEWP to be in good working condition, it is important that the operator meets the necessary qualifications and follow the maintenance and inspection schedule referred to in this section.

3.1-1 Operator Qualifications

- Only trained and authorized personnel shall be permitted to operate an MEWP.
- Safe use of this MEWP requires the operator to understand the limitations and warnings, operating procedures and operator's responsibility for maintenance. Accordingly, the operator must understand and be familiar with this operating manual, its warnings and instructions, and all warnings and instructions on the MEWP.
- The operator must be familiar with employer's work rules and related government regulations and be able to demonstrate the ability to understand and operate this make and model of MEWP in the presence of a qualified person.

3.1-2 Operator's Responsibility for Maintenance



WARNING

Maintenance must be performed by trained and competent personnel who are familiar with mechanical procedures.

Death or serious injury could result from the use of an MEWP that is not properly maintained or kept in good working condition.

- The operator must be sure that the MEWP has been properly maintained and inspected before using it.
- The operator must be sure that a complete and legible copy of the Certificate of Inspection and Testing kept in the provided weather-resistant storage compartment on the MEWP at all times.
- The operator must perform all the daily inspections and function tests found in [Table 4.7](#), even if the operator is not directly responsible for the maintenance of this MEWP.

3.1-3 Maintenance and Inspection Schedule

- The inspection points covered in [Table 4.7](#) indicate the areas of the MEWP to be maintained or inspected and at what intervals the maintenance and inspections are to be performed.
- The actual operating environment of the MEWP may affect the maintenance schedule.



WARNING

Use original or manufacturer-approved parts and components for the MEWP.

3.1-4 Owner's Inspections

It is the responsibility of the owner to arrange daily, quarterly (or 150 hours) and annual inspections of the MEWP. Refer to [Table 4.7](#) for recommended maintenance and inspection areas and intervals. A record of annual inspection is kept on a label located close to the base control console on the cowling. Refer to [Table 4.3](#) in this manual.

NOTE

Inspection scheduling requirements may vary. Owners must comply with local standards and regulations.

3.2 Major Components

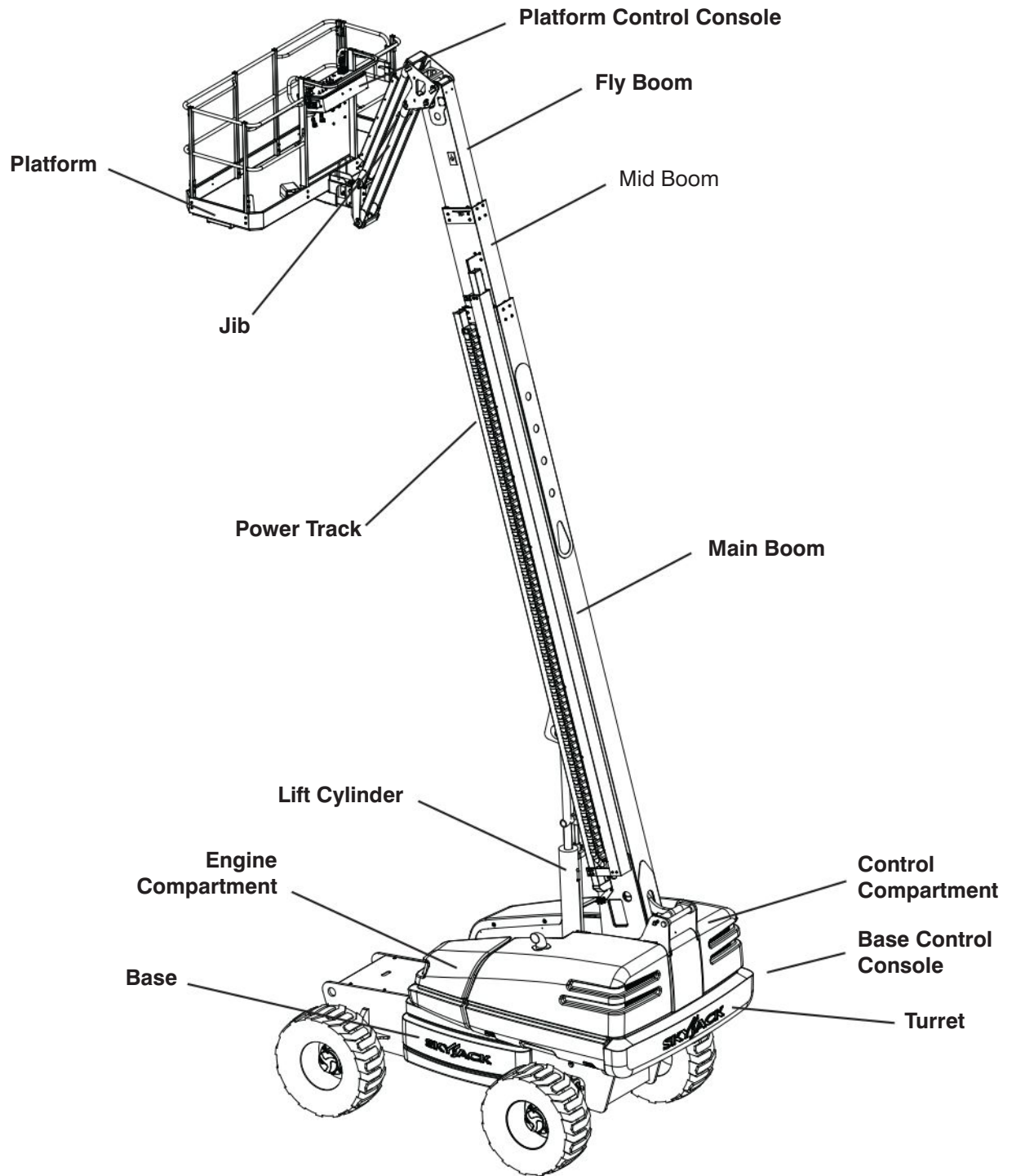

SKYJACK Telescopic Boom

3.3 Major Assemblies

The MEWP consists of four major assemblies: the base, turret, boom assembly and platform.

3.3-1 Base

The base is a rigid one-piece weldment. The rear axle is hydraulic motor-driven and has a spring-applied, hydraulically released brakes. The front axle is steerable by a hydraulic cylinder and has spring-applied, hydraulically released brakes. The rear axle is coupled to the front axle by a drive shaft.

3.3-2 Turret

The turret rotates 360 degrees continuously. Upon the turret are two compartments. One compartment contains the engine, hydraulic pumps, battery and swing drive. The other compartment contains the base control console, main hydraulic manifold, function valves, the hydraulic and fuel tanks.

3.3-3 Boom Assembly

The boom is mounted on the turret and consists of a telescoping fly and main boom assembly. Model 66T has an additional mid boom section. The telescoping boom mechanism uses two double-acting hydraulic cylinders with holding valves to control vertical movement. Cables are used to extend the fly boom section. SJ 66T model is equipped with a 152 cm (60 in.) boom jib, controlled by a double-acting hydraulic cylinder.

3.3-4 Platform

The platform is constructed of a skid-resistant deck surface allowing visibility through the deck and a 110 cm (43 in.) high tubular steel railing system with mid rails and 15 cm (6 in.) toe boards. The platform can be entered through a swing center gate or an optional swing gate at the side of the railing system. The platform can be rotated in either direction. An optional AC outlet is also located on the platform.

3.4 Serial Number Nameplate

The serial number nameplate, located at the rear of the MEWP, lists the following:

- Model number
- Serial number
- Maximum capacities
- Maximum number of persons permissible on the platform
- Maximum manual force
- MEWP weight
- Maximum drivable height
- Maximum platform height
- System pressure
- Lift pressure
- Maximum wheel load
- Maximum wind speed
- Voltage
- Maximum inclination of chassis

3.5 Component Identification

The following descriptions are for identification, explanation and locating purposes only.

3.5-1 Manual Storage Box

This weather-resistant box is mounted under the control console on the platform. It contains the operating manual, EC declaration and other important documents. The operating manual for this make and model of MEWP must remain with the MEWP and should be stored in this box.



3.5-2 Turret Transportation Lock

This locking device is located in the turret.

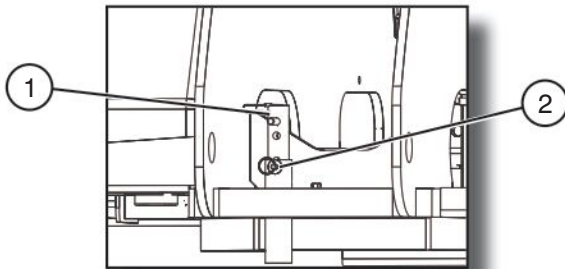

Figure 3-1. Turret Transportation Lock

1. **Turret Transportation Lock** - This locking device is used to lock turret in place during shipping only.
2. **Turret Transportation Lock Retaining Pin** - This retaining pin is used to hold transportation lock in either locked or unlocked position.

Refer to [Section 3.10-2](#) for procedure on how to lock the turret.

3.5-3 All Motion Alarm

This alarm produces an audible sound when any boom function is activated. On MEWPs with certain options, a flashing amber light will accompany this alarm.

3.5-4 AC Outlet on Platform (If Equipped)

This outlet is a source of AC power on the platform. The outlet is located on the right side of platform control console and the plug is located beside hydraulic tank in control compartment.

3.6 Component Identification (Optional Equipment/Attachments)

The following descriptions are for identification, explanation and locating purposes only.

3.6-1 Cold Weather Start (If Equipped)

The battery warmer/hydraulic oil heater cord is located on the engine compartment near the battery.

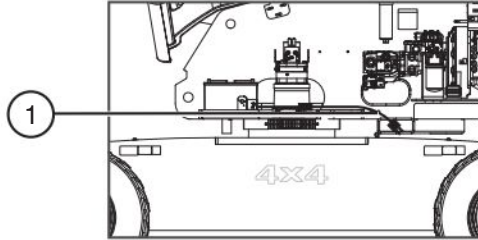

Figure 3-2. Battery Warmer/Hydraulic Oil Heater Cord

1. **Battery Warmer/Hydraulic Oil Heater Cord** - This cord is plugged into the AC outlet at least 4 hours before starting engine when temperature gets below -11°C (+11°F).

3.6-2 Welder (If Equipped)

The welder is installed on the platform. Refer to welder's operating manual for proper operation and maintenance.

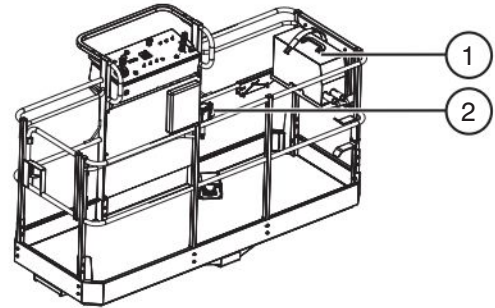

Figure 3-3. Welder

1. **Welder** - This equipment is plugged into its dedicated AC outlet on the platform.
2. **Welder AC Outlet** - This AC outlet is dedicated for the welder.

NOTE

In sub-zero temperatures, the hydraulic oil should be warmed, prior to operating the welder.



WARNING

Only qualified persons should install, operate, maintain and repair the welder.



CAUTION

Breathing welding fumes and gases can be hazardous to your health.

3.6-3 Work Light (If Equipped)

The work light assembly is mounted on the railings of the platform.

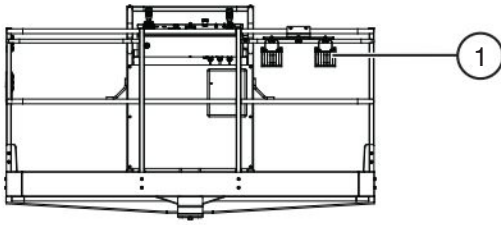

Figure 3-4. Work Light

1. **Work Light** - This light turns on when plugged into the AC outlet on the platform.

**WARNING**

Work lights are not intended to replace the ambient lighting required to navigate and operate this MEWP.

3.6-4 Flashing Amber Light (If Equipped)

The flashing amber light is located on top of the turret of the MEWP.

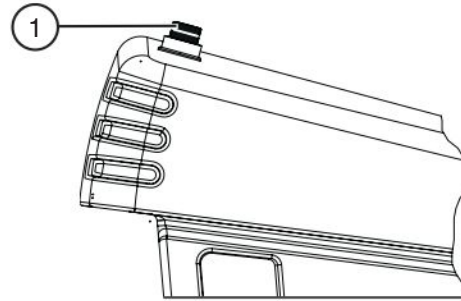

Figure 3-5. Flashing Amber Light

1. **Flashing Amber Light** - This light flashes when boom function is activated. This works in conjunction with all motion alarm.

NOTE

The combined weight of attachment, panels, occupants and tools should not exceed platform rated capacity.

3.7 Operator's Responsibility

It is the responsibility of the operator, prior to each work shift, to perform the following:

1. Visual and Daily Maintenance Inspections

- are designed to discover any damage of components before the MEWP is put into service.
- are done before the operator performs the function tests.



WARNING

Failure to locate and repair damage, and discover loose or missing parts may result in an unsafe operating condition.

2. Function Tests

- are designed to discover any malfunctions before the MEWP is put into service.

IMPORTANT

The operator must understand and follow the step-by-step instructions to test all MEWP functions.

The operator should make a copy of the Operator's Checklist (see [Table 4.8](#)) and fill out the visual and daily maintenance inspections and the function tests sections while performing the items outlined in [Section 2.3](#) and [Section 2.4](#).

IMPORTANT

If MEWP is damaged or any unauthorized variation from factory-delivered condition is discovered, MEWP must be tagged and removed from service.

Repairs to the MEWP may only be made by a qualified service technician. After repairs are completed, the operator must perform visual and daily maintenance inspections & function tests again.

Scheduled maintenance inspections shall only be performed by qualified service technician (see [Table 4.7](#)).

3.8 Start Operation

Carefully read and completely understand the Operating Manual and all warnings and instruction labels (refer to [Section 5](#) - Labels) on the MEWP.



WARNING

DO NOT operate this MEWP without proper authorization and training. Failure to avoid this hazard could result in death or serious injury.

Before operating this MEWP, perform the following steps:

1. Visual and daily maintenance inspections (see [Section 2.3](#))
2. Function tests (see [Section 2.4](#))
3. Jobsite inspection
It is the responsibility of the operator to perform a jobsite inspection and avoid the following hazardous situations:
 - holes or drop-offs
 - ditches or soft fills
 - floor obstructions, bumps or debris
 - overhead obstructions
 - electrical cords, hoses and high voltage conductors
 - hazardous locations
 - inadequate surface support to withstand all load forces imposed by the MEWP
 - wind and weather conditions
 - the presence of unauthorized personnel
 - other possible unsafe conditions



WARNING

An operator should not use any MEWP that:

- **does not appear to be working properly.**
- **has been damaged or appears to have worn or missing parts.**
- **has alterations or modifications not approved by the manufacturer.**
- **has safety devices which have been altered or disabled.**
- **has been tagged or locked out for non-use or repair.**





Failure to avoid these hazards could result in death or serious injury.

3.8-1 To Activate Base Control Console



WARNING

Ensure that you maintain three points of contact to mount/dismount the platform.

1. Enter platform and close gate.
2. On platform control console, pull out “” emergency stop button.
3. In engine compartment, turn main power disconnect switch to “I” on position.
4. On base control console, turn off/base/platform key switch to “” base position.
5. Pull out “” emergency stop button.
6. Select “” start position from start/function enable/emergency power switch until engine starts.





WARNING

DO NOT over crank the starter. If engine fails to start after multiple attempts, contact a Service Technician.

For MEWP with cold weather start option:

7. Disconnect battery warmer/hydraulic oil heater from AC outlet after engine starts.
8. Allow engine to run, for approximately 10 minutes, to reach operating temperature before driving.

3.8-2 To Rotate Platform Using Base Control Console



1. Activate function enable “” by selecting and holding start/function enable/emergency power switch to function enable position.
2. Push platform rotation switch to either “” left or “” right position. Release switch to stop.

3.8-3 To Rotate Turret Using Base Control Console



WARNING



When rotating the turret, ensure that there are no personnel or obstructions in the path of rotation, including blind spots.

1. Activate function enable “” by selecting and holding start/function enable/emergency power switch to function enable position.
2. Push turret rotation switch to either “” clockwise or “” counterclockwise position. Release switch to stop.



NOTE

Turret can be rotated continuously 360 degrees.



3.8-4 To Move Jib Up and Down Using Base Control Console

1. Activate function enable “” by selecting and holding start/function enable/emergency power switch to function enable position.
2. Push jib up/down switch to either “” up or “” down position. Release switch to stop.



3.8-5 To Raise or Lower Main Boom Using Base Control Console

1. Activate function enable “” by selecting and holding start/function enable/emergency power switch to function enable position.
2. Push main boom raise/lower switch to either “” raise or “” lower position. Release switch to stop.

3.8-6 To Extend or Retract Fly Boom Using Base Control Console

1. Activate function enable “” by selecting and holding start/function enable/emergency power switch to function enable position.
2. Push fly boom extend/retract switch to either “” extend or “” retract position. Release switch to stop.



3.8-7 To Level Platform Using Base Control Console

1. Activate function enable “” by selecting and holding start/function enable/emergency power switch to function enable position.
2. Push platform leveling override switch to either “” up or “” down position. Release switch to stop.

3.8-8 To Operate Using Emergency Power Switch at Base Control Console

This is a momentary-type switch. This switch allows all functions except the drive function to operate in the event of engine malfunction. Refer to [Section 2.6](#) for the emergency lowering procedure.

3.8-9 To Activate Platform Control Console

1. In engine compartment, turn main power disconnect switch to “I” on position.
2. On base control console, turn off/base/platform key switch to “” platform position.
3. On base control console, pull out “” emergency stop button.





Ensure that you maintain three points of contact to mount/dismount the platform.



DO NOT operate any control on operator’s control console without proper fall protection secured to the designated location in the platform. Failure to avoid this hazard could result in death or serious injury.

4. Enter platform and close gate.
5. Attach body harness lanyards of each occupant to platform lanyard rings.



6. On platform control console, pull out “” emergency stop button.
7. Select “” start position from engine start/on/off switch until engine starts.



DO NOT over crank the starter. If engine fails to start after multiple attempts, contact a Service Technician.

NOTE

Engine will not start if you are pressing down on the footswitch.

8. Select desired engine RPM using throttle switch: “” high or “” low.





- **DO NOT drive or steer the MEWP when the platform position does not allow you a clear view of the base.**
- **Your area of operation should be cordoned from other personnel or equipment.**

3.8-10 To Drive Forward or Reverse Using Platform Control Console



CAUTION

When you are in the platform and positioned over an axle, the direction you are facing will be forward.



1. Depress and hold footswitch.
2. Push and hold drive/steer controller in this direction  to drive forward or  to drive backward.
3. Release controller handle to stop.



DANGER

The drive orientation can change when the turret is swung 90 degrees off center of the normal driving position (roughly when boom is swung past the rear tire). Drive re-orientation will not occur while driving and rotating until the joystick is released for 6 seconds or when the footswitch is released.



3.8-11 To Steer Using Platform Control Console

1. Depress and hold footswitch.
2. Press rocker on top of drive/steer controller in this direction  to steer left or  to steer right.



NOTE

Driving and steering may be active at the same time.



3.8-12 To Move Jib Up and Down Using Platform Control Console

1. Depress and hold footswitch.
2. On jib up/down switch, select  to move jib up or  to move jib down. Vary speed with  boom speed adjuster dial. Release switch to stop.



3.8-13 To Extend or Retract Fly Boom Using Platform Control Console

1. Depress and hold footswitch.
2. On fly boom extend/retract switch, select  to extend fly boom or  to retract fly boom. Vary speed with  boom speed adjuster dial. Release switch to stop.



3.8-14 To Level Platform Using Platform Control Console

1. Depress and hold footswitch.
2. On platform leveling override switch, move switch to upward position  to tilt platform up or move switch to downward position  to tilt platform down. Release switch to stop.

3.8-15 To Rotate Platform Using Platform Control Console

1. Depress and hold footswitch.
2. On platform rotation switch, select  to rotate platform left or  to rotate platform right. Vary speed with  boom speed adjuster dial. Release switch to stop.

3.8-16 To Raise or Lower Main Boom Using Platform Control Console

1. Depress and hold footswitch.
2. Push and hold boom/turret controller in this direction  to raise main boom or  to lower main boom.
3. Release controller handle to stop.

3.8-17 To Sound Horn



1. Press  horn pushbutton to sound horn. Release pushbutton to stop sounding horn.

3.8-18 To Rotate Turret Using Platform Control Console



WARNING

When rotating the turret, ensure that there are no personnel or obstructions in the path of rotation, including blind spots.

1. Depress and hold footswitch.
2. Push and hold boom/turret controller in this direction  to rotate clockwise or  to rotate counterclockwise.
3. Release controller handle to stop.



NOTE

Turret can be rotated continuously 360 degrees.

3.8-19 To Operate Using Emergency Power Switch at Platform Control Console

This is a momentary-type switch. This switch allows all functions except drive function to operate in the event of engine malfunction. Refer to [Section 2.6](#) for the emergency lowering procedure.

3.8-20 Shutdown Procedure

1. Completely retract boom and lower platform.
2. Push in  emergency stop button on platform control console and on base control console.
3. Turn base/off/platform key switch to  off position. Remove key.
4. Turn main power disconnect switch to  off position.

For MEWP with cold weather start option:

NOTE

When temperature gets below -11°C ($+11^{\circ}\text{F}$), ensure MEWP is parked close to AC outlet.

5. Plug in battery warmer/hydraulic oil heater into AC outlet at least 4 hours before starting engine.

3.8-21 Hydraulic Generator (If Equipped)

To start hydraulic generator:

1. Ensure engine is running.
2. On platform control console, turn generator on/off switch to  on position.

To restore normal operation:

1. On platform control console, turn generator on/off switch to  off position.

NOTE

An engine shut down will turn the generator off. Normal boom functions are disabled while the generator is on.

3.9 Refueling Procedure

This section provides the operator with procedure on how to refuel engine with regular fuel.

IMPORTANT

Before using your MEWP ensure there is enough fuel for expected use.



WARNING

Failure to heed the following safety precautions could result in death or serious injury:

- **Use extreme caution while refueling MEWPs.**
- **Ensure that engine and all systems are turned off before refueling.**
- **Refuel the MEWP only in a well ventilated area away from open flame and other sources of ignition, authorized by your employer and supervisor.**



WARNING

Do not smoke in an area where MEWPs are stored or refueled.

3.9-1 Regular Fuel (Diesel)

IMPORTANT

Use unleaded gasoline only.

1. Ensure engine and all systems are turned off and emergency stop buttons are depressed.
2. Open control compartment and remove fuel cap.
3. Carefully fill the fuel tank ensuring that no spillage occurs.
4. Secure fuel cap.
5. Ensure there are no leaks in fuel system.
6. Wipe up any spilled fuel.
7. Dispose of rags in an approved container.

3.10 Loading/Unloading

Know and heed all national, state/provincial and local rules which apply to transporting of MEWPs.

Only qualified personnel shall operate MEWP during loading/unloading.

Be sure vehicle capacity and loading equipment hoists, chains, straps, etc., are sufficient to withstand maximum MEWP weight.

The transport vehicle must be parked on a level surface and must be secured to prevent rolling while MEWP is being loaded or unloaded.

3.10-1 Loading and Tie-down

1. Lock turret using turret transportation lock (refer to [Section 3.10-2](#)).
2. Turn key switch to “○” off position and remove key before transporting.
3. Turn main power disconnect switch to “○” off position.
4. Chock MEWP wheels (if necessary).
5. Remove all loose items.
6. Anchor down MEWP to transport surface using tie-down points (refer to [Figure 3-6](#)).
7. Secure boom from side-to-side movement using lower platform mount between boom end and platform. Do not use excessive downward force when securing boom section.



WARNING

Inspect MEWP for loose or unsecured items.

NOTE

For loading and unloading using a winch line, refer to [Section 2.5](#).

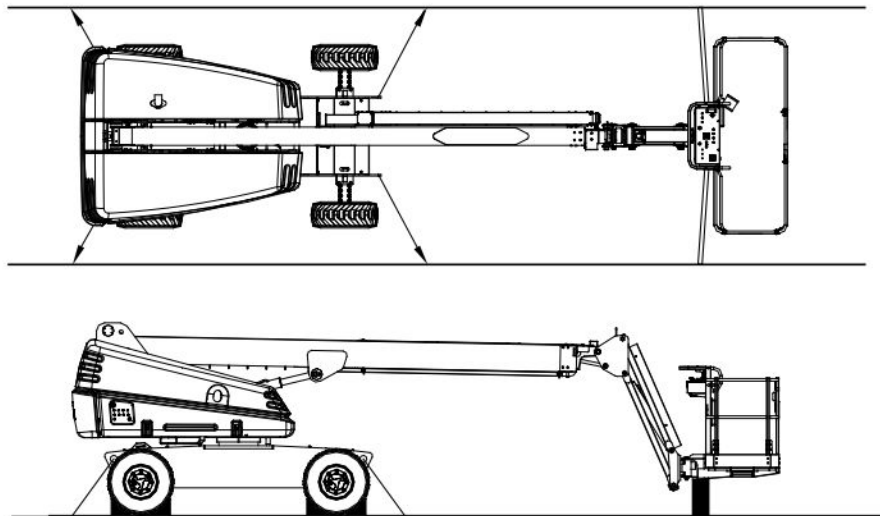

Figure 3-6. Tie-down Points

3.10-2 Locking the Turret

1. Ensure that turret is positioned so that turret transportation lock (item 1 - Figure 3-7) is aligned into one of four turret locking points.

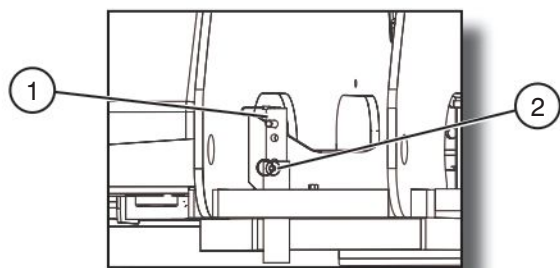

Figure 3-7. Turret Transportation Lock

2. Pull out turret lock retaining pin (item 2 - Figure 3-7). Lower turret lock into locked position and reinsert turret lock retaining pin.

3.10-3 Lifting

1. Rotate the boom and position the MEWP as shown in Figure 3-8 and Figure 3-9.

2. Turn main power disconnect switch to “O” off position.
3. Clear platform of all personnel, tools and materials.



WARNING

When lifting the MEWP, lifting devices must be attached to designated lift points only (refer to Figure 3-9 and Figure 3-10).



WARNING

Use chains with load capacity sufficient to withstand MEWP weight. Refer to the serial plate of the MEWP for specific weight.

4. Properly adjust rigging to ensure MEWP remains level during lifting. See Center of gravity location (Figure 3-8).

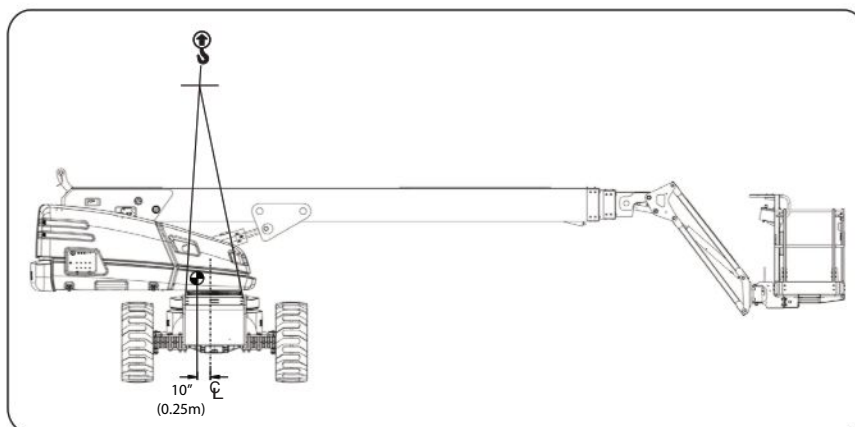

Figure 3-8. Center of Gravity

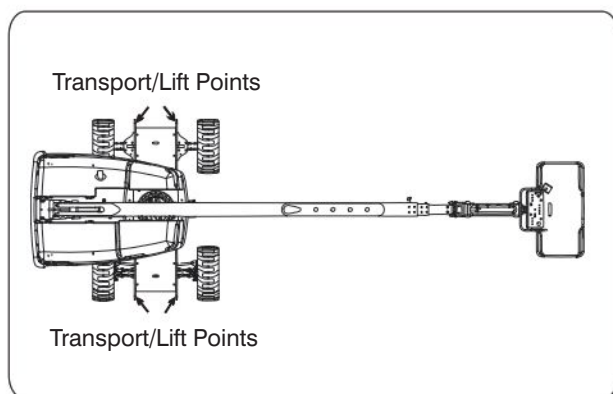

Figure 3-9. Overhead View Lifting Points

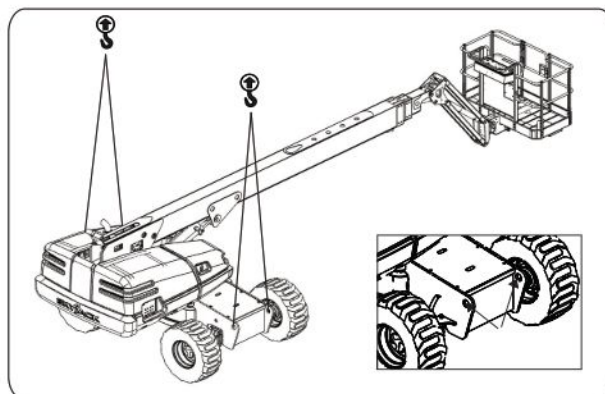

Figure 3-10. Lifting Points

3.11 Chassis Tilt

This section guides the operator with regard to recovering from an inclined position.

IMPORTANT

When the boom is raised or extended, the MEWP must only be operated on firm level surfaces.



WARNING

If the MEWP becomes tilted causing the alarm to sound, the platform must be fully lowered and retracted immediately. Drive functions are not available when the tilt alarm is active.

3.11-1 Counterweight Uphill

If the MEWP becomes tilted with the counterweight uphill (refer to Figure 3-11) follow the steps below to return to a lowered and retracted position.

1. Retract the fly boom completely
2. Drive to a firm level surface.

3.11-2 Counterweight Downhill

If the MEWP becomes tilted with the counterweight downhill (refer to Figure 3-12) follow the steps below to return to a lowered and retracted position.

1. Lower the jib to horizontal (if equipped).
2. Retract the fly boom completely.
3. Lower the main boom completely.
4. Drive to a firm level surface.

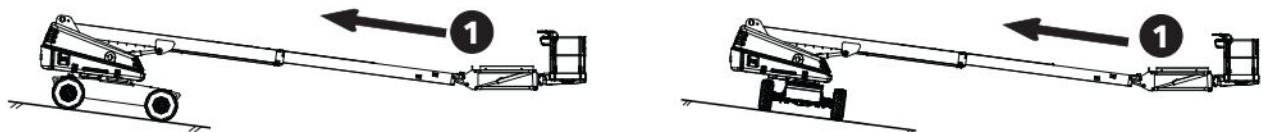

Figure 3-11. Counterweight Uphill

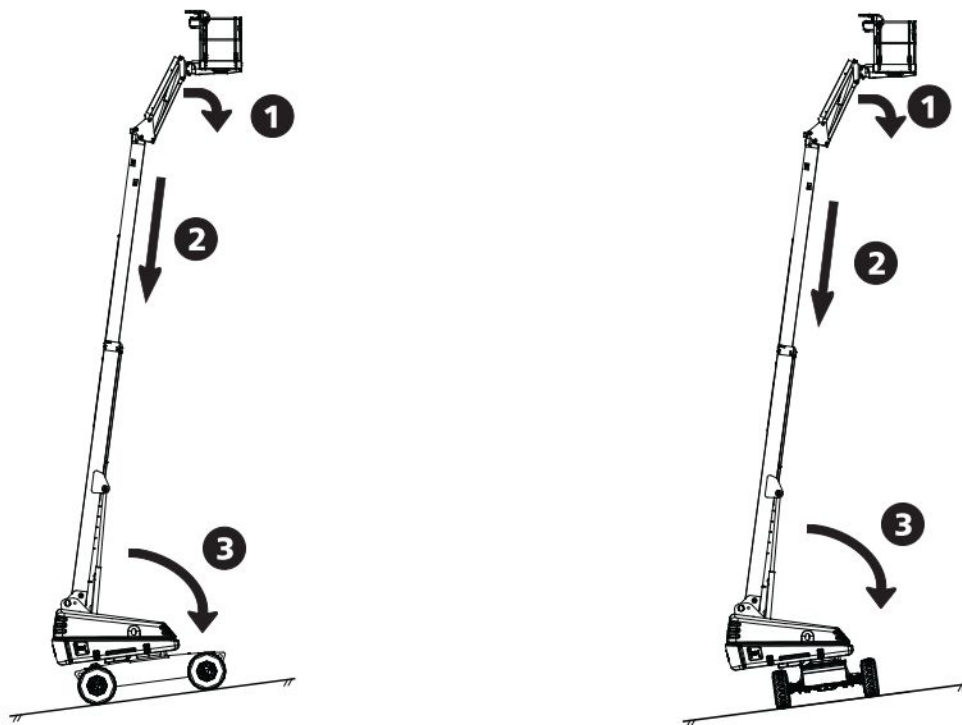

Figure 3-12. Counterweight Downhill

Diagram 3.1 Dimension and Reach Diagram

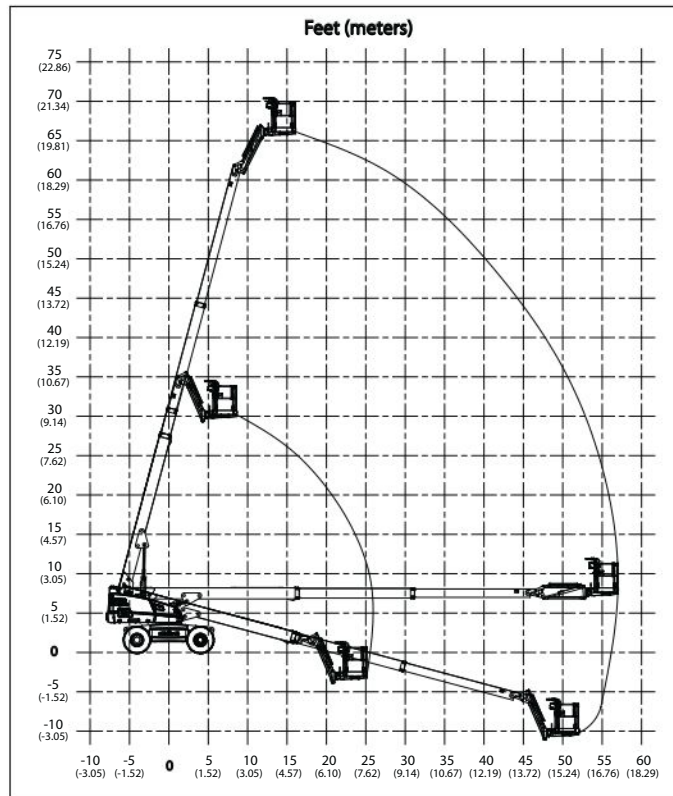

Figure 3-13. Reach Diagram

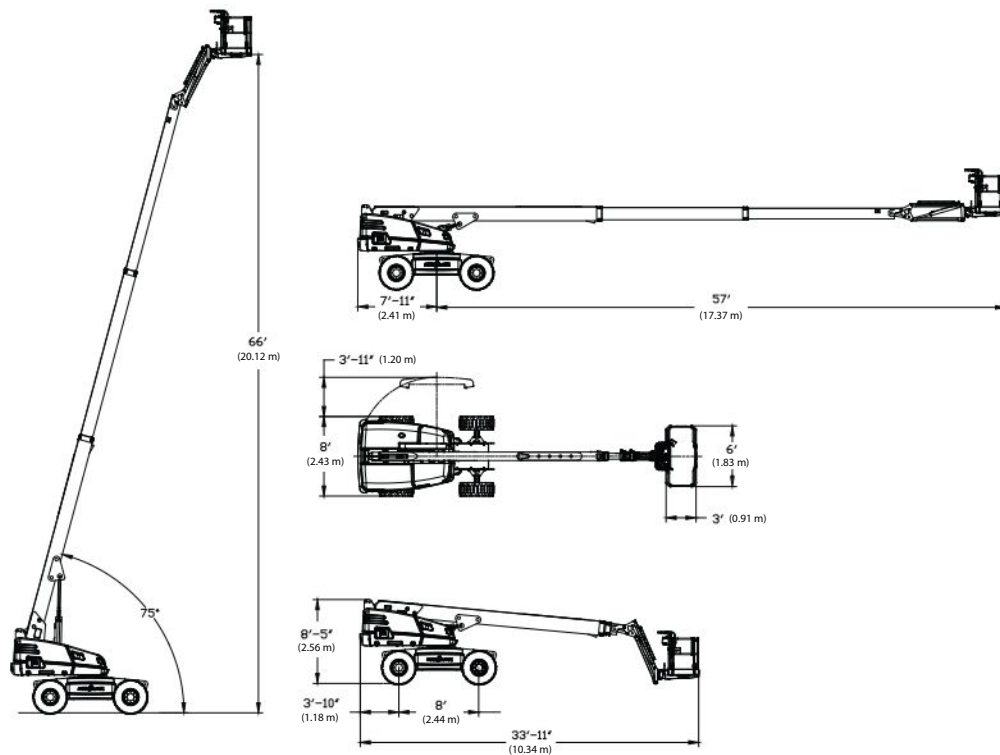
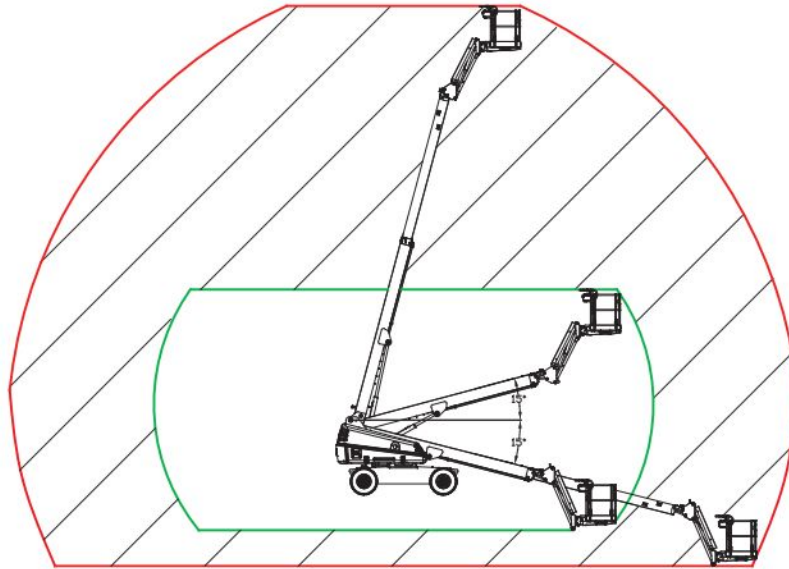

Figure 3-14. Dimensions

Diagram 3.2 Axle Oscillation Diagram



Do not raise the platform in work mode if it is not on a firm level surface.





-  Axle oscillation free (travel mode) - drive speed 7.2 km/h (4.5 mph) max.
-  Axle oscillation locked (work mode) - drive speed 0.8 km/h (0.5 mph) max.

Figure 3-15. Axle Oscillation

Table 4.1 Standard and Optional Features

MODEL	SJ 66T
STANDARD EQUIPMENT	
12 Volt DC emergency power	✓
5-foot jib	✓
72 x 36 inch platform (Rear gate)	✓
Base controls	✓
Continuous drive and steer directional sensing	✓
Diesel engine	✓
Engine anti-restart protection	✓
Foam filled tires	✓
Four-wheel drive	✓
Glow plug heaters	✓
Load sensing system	✓
Manual brake release	✓
Operator horn	✓
Oscillating axle (steer)	✓
Platform controls	✓
Rear entry spring hinged gate	✓
Spring-applied hydraulically released brake	✓
Variable speed drive and function controls	✓
OPTIONAL EQUIPMENT	
3500W hydraulic generator	✓
Receptacle outlet cable on platform	✓
96 x 36 inch platform (Side gate)	✓
Air line or hydraulic line to platform	✓
All function motion alarm	✓
Base driving light	Not Available
Catalytic Muffler (Level 1)	✓
Catalytic Muffler (Level 2)	✓
Cold weather start kit (diesel)	✓
Flashing amber light	✓
Oil cooler (included with generators)	✓
Platform work light	✓

1098AB-CE

NOTE: Only manufacturer-approved options are to be utilized.

Table 4.2a Specifications and Features

MODEL		SJ 66T
Platform Size	Total platform length (outside)	182.9 cm / 244 cm
	Total platform depth (outside)	91.4 cm
Height	Working	22.1 m
	Platform elevated	20.1 m
	Drive	driveable at all heights
	Turret	2.6 m
Length	Overall with platform	10.3 m
	Base and tires	3.5 m
Width	Outside std. tires	2.4 m
	Turret	2.3 m
Weight	Weight (with foam-filled tires)	12,800 kg
Platform rotation		175 degrees
Horizontal reach		17.4 m
Wheelbase		2.4 m
Turret rotation		360 degrees continuous
Turret tailswing		133 cm
Gradeability (torque equivalent to)		50%
Whole-body vibration on the platform		0.4 m/sec ²
Ground clearance between wheels		36 cm
Turning Radius	Inside	4WD
	Outside	
System voltage		12 VDC
Battery	Type	Lead Acid
	Cold cranking amperes	800 A
Operating Times	Main boom up	76 - 84 seconds (approx.)
	Main boom down	76 - 84 seconds (approx.)
	Fly boom extend	50 - 70 seconds (approx.)
	Fly boom retract	40 - 50 seconds (approx.)
	Jib up	25 - 45 seconds (approx.)
	Jib down	16 - 20 seconds (approx.)
	Turret rotate - 360° (fully stowed)	160 - 180 seconds (approx.)
	Platform rotate - 180°	7 - 15 seconds (approx.)
Driving Speeds	Drive Speed (maximum-stowed)	7.2 km/h
	Drive Speed (maximum-elevated)	0.8 km/h





1099AC-CE

Table 4.2b Specifications and Features

MODEL			SJ 66T	
Engine - Deutz	Engine Type		Deutz TD2.9	
	Fuel Type		Diesel	
	Fuel Tank Capacity		170.3 L	
	Standard Oil Factory Fill	Ambient Temperature Limits	- 18°C to +45°C (0°F to 115°F)	
	Cold Lube Oil Option		- 29°C to +32°C (- 20°F to 90°F)	
	Arctic Lube Oil Option		- 40°C to +45°C (- 40°F to 115°F)	
	Approved Alternates			
	Lube Oil Sump Capacity		9 L	
	Radiator Capacity		13L	
Radiator Fluid Type		DELO ELC 50/50		
Hydraulic Oil	Recommended Oil	Type		Shell Tellus T46
		Operating and Oil Temperature Limits	Ambient Operation	+45°C (113°F)
			Max. Oil Temp.	+93°C (200°F)
	Alternates <i>(Note: Cold weather starting temperatures can be improved with Skyjack options. Please consult your nearest Skyjack service center.)</i>		HVLP T46 (Summer)	
			HVLP T42 (Winter)	
	Tank Capacity		223.3 L	
Sound Pressure Level (ISO 3744)			80dB(A)	
Sound Pressure Level (LAFeq) at Platform			78dB(A)	
Guaranteed Sound Power Level (ISO 4871)			112dB	
Vibration acceleration to which operator's body is subjected does not exceed 0.5 m/s ² .				

1100AE-CE

Table 4.3 Owner’s Annual Inspection Record

										
 Model Number: _____ Serial Number: _____										
*		20__	20__	20__	20__	20__	20__	20__	20__	20__
**										

1001AB

This decal is located on the control compartment cowling. It must be completed after an annual inspection has been completed. Do not use the aerial platform if an inspection has not been recorded in the last 6 months.



	Pictorial	Description
*		Inspection Date
**		Inspector Signature

Table 4.4 Tire/Wheel Specifications

	SJ 66T
Tire Size	38.1 cm x 49.5 cm
Type	Foam-filled
Tire Ply Rating	16
Wheel Nuts Torque	393.2 Nm

1102AC-CE

IMPORTANT

For proper function of each axle differential, all four wheels must have same tire size installed at all times. Failure to comply with this requirement will reduce the life of the differentials and reduce overall mobility of MEWP.

Table 4.5 Maximum Platform Capacities

	SJ 66T
Total Capacity	227 kg
	2 Persons
Maximum Wind	12.5 m/s
Maximum Side Force	400 N
Tilt Cutout Setting	5 degrees x 5 degrees

1101AC-CE

Table 4.6 Floor Loading Pressure

MODEL	Gross Aerial Platform Weight	Total Aerial Platform Load		
		Wheel	LCP	OUP
	kg	kg	kPa	kPa
SJ 66T (Standard configuration)	13,027	6,300	1,140	17.8

1103AC-CE

- Standard Configuration (66T) = 4WD + Oscillating Axle + 38.1cm x 49.5 cm Foam Tires
- Gross Aerial Platform Weight = Weight + platform capacity
- LCP – Locally Concentrated Pressure – is a measure of how hard the aerial platform tire tread presses on the area in direct contact with the floor. The floor covering (tile, carpet, etc.) must be able to withstand more than the indicated values above.
- OUP – Overall Uniform Pressure – is a measure of the average load the aerial platform imparts on the whole surface projected directly underneath it. The structure of the operating surface (beams, etc.) must be able to withstand more than the indicated values above.
- Welder option will add approximately 158.8 kg (350 lb.) to total aerial platform weight and 79.4 kg (175 lb.) to max. wheel load.

NOTE:

The LCP or OUP that an individual surface can withstand varies from structure to structure and is generally determined by the engineer or architect for that particular structure.

Locally Concentrated Pressure (LCP):

Foot Print Area identified by test.

$$LCP = \frac{\text{Wheel Load}}{\text{Foot Print Area}}$$

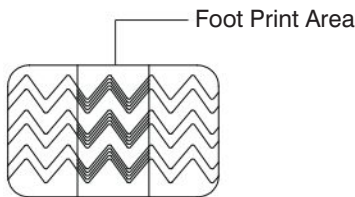
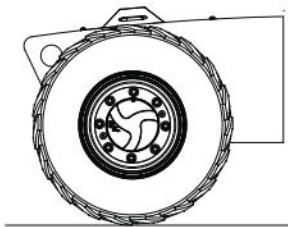

Overall Uniform Pressure (OUP):

Base Area = Length x Width

$$OUP = \frac{\text{MEWP Weight + Capacity}}{\text{Base Area}}$$

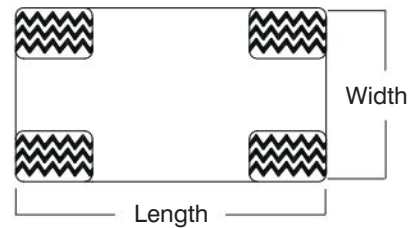
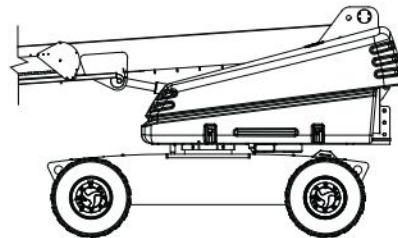

WARNING

Intermixing tires of different types or using tires of types other than those originally supplied with this equipment can adversely affect stability. Therefore, replace tires only with the exact Skyjack-approved type. Failure to operate with matched approved tires in good condition may result in death or serious injury.

General Maintenance

Before attempting any repair work, disconnect battery by turning main power disconnect switch to “○” off position. Preventive maintenance is the easiest and least expensive type of maintenance.

Table 4.7 Maintenance and Inspection Schedule

Frequency	Daily	3 months or 150 hours	Yearly	Frequency	Daily	3 months or 150 hours	Yearly
Visual and Daily Maintenance Inspections				Load Cell	A		
Labels	A			Jib	A		
Electrical	A			Boom	A		
Limit Switches	A			Cylinders	A		
Hydraulic	A			Wear Pads	A		
Engine Compartment				Hoses	A		
Main Power Disconnect Switch	A			Power Track	A		
Batteries	A			Cables	A		
Swing Drive Motor	A			Optional Equipment/Attachments			
Turret Rotation Gear	A			Hydraulic Generator (If Equipped)	A		
Rotary Manifold	A			Battery Warmer/Hydraulic Oil Heater (If Equipped)	A		
Hydraulic Pumps	A			Welder (If Equipped)	A		
Muffler and Exhaust	A			Work Light (If Equipped)	A		
Engine Pivot Tray	A			Flashing Amber Light (If Equipped)	A		
Engine Oil Level	A			Function Tests			
Engine Air Filter	A			Test Main Power Disconnect Switch	A		
Fuel Leaks	A			Base Control Console			
Control Compartment				Test Emergency Stop	A		
Base Control Console	A			Test Function Enable Switch & All Boom Functions	A		
Hydraulic Tank	A			Test Platform Self-leveling	A		
Hydraulic Oil	A			Test Emergency Power	A		
Hydraulic Return Filter	A			Test Base/Off/Platform Switch	A		
Brake and Main Manifolds	A			Platform Control Console			
Emergency Power Unit	A			Test Load Sensing System	A		
Fuel Tank	A			Test Footswitch	A		
Fuel Leaks	A			Test Engine Enable Switch	A		
Base				Test Emergency Stop	A		
Turret Transportation Lock	A			Test Steering	A		
Drive Axle	A			Test Driving Function	A		
Oscillating Cylinder Assembly	A			Test Driving Speed	A		
Steer Cylinder Assembly	A			Test Emergency Power	A		
Tie Rod	A			Test Horn	A		
Wheel/Tire Assembly	A			Test Brakes	A		
Manuals	A			Test Manual Platform Leveling	A		
Platform Assembly	A			Test Oscillating Axles	A		
Platform Control Console	A			Test Cables	A		
Rotary Actuator	A						

B*†

B*†

B*†

1104AC-CE

A - Perform Visual and Daily Maintenance Inspections & Functions Test. Refer to Section 2.3 and Section 2.4 of this manual.

B - Perform Scheduled Maintenance Inspection. Refer to Service & Maintenance manual.

* - Maintenance must be performed only by trained and competent personnel who are familiar with mechanical procedures.

† - Refer to Skyjack's website @ www.skyjack.com for latest service bulletins prior to performing quarterly or yearly inspection.



WARNING

Use original or manufacturer-approved parts and components for MEWP.

Table 4.8 Operator’s Checklist



Serial Number: _____
 Model: _____
 Hourmeter Reading: _____
 Date: _____
 Time: _____

Operator's Name (Printed): _____
 Operator's Signature: _____

Each item shall be inspected using the appropriate section of the Skyjack operating manual.
 As each item is inspected, check the appropriate box.

- P** - PASS
- F** - FAIL
- R** - REPAIRED
- NA** - NOT APPLICABLE

INSPECTION FREQUENCY

- DAILY
- FREQUENTLY
- ANNUALLY
- BI-ANNUALLY

	N/A	P	F	R
Visual and Daily Maintenance Inspections				
Labels				
Electrical				
Limit Switches				
Hydraulic				
Engine Compartment				
Main Power Disconnect Switch				
Batteries				
Swing Drive Motor				
Turret Rotation Gear				
Rotary Manifold				
Hydraulic Pumps				
Muffler and Exhaust				
Engine Pivot Tray				
Engine Oil Level				
Engine Air Filter				
Fuel Leaks				
Control Compartment				
Base Control Console				
Hydraulic Tank				
Hydraulic Oil				
Hydraulic Return Filter				
Brake and Main Manifolds				
Emergency Power Unit				
Fuel Tank				
Fuel Leaks				
Base				
Turret Transportation Lock				
Drive Axle				
Oscillating Cylinder Assembly				
Steer Cylinder Assembly				
Tie Rod				
Wheel/Tire Assembly				
Manuels				
Platform Assembly				
Platform Control Console				
Rotary Actuator				

	N/A	P	F	R
Load Cell				
Jib				
Boom				
Cylinders				
Wear Pads				
Hoses				
Power Track				
Cables				
Optional Equipment/Attachments				
Hydraulic Generator (If Equipped)				
Battery Warmer/Hydraulic Oil Heater (If Equipped)				
Welder (If Equipped)				
Work Light (If Equipped)				
Flashing Amber Light (If Equipped)				
Function Tests				
Test Main Power Disconnect Switch				
Base Control Console				
Test Emergency Stop				
Test Function Enable Switch & All Boom Functions				
Test Platform Self-leveling				
Test Emergency Power				
Test Base/Off/Platform Switch				
Platform Control Console				
Test Load Sensing System				
Test Footswitch				
Test Engine Enable Switch				
Test Emergency Stop				
Test Steering				
Test Driving Function				
Test Driving Speed				
Test Emergency Power				
Test Horn				
Test Brakes				
Test Manual Platform Leveling				
Test Oscillating Axles				
Test Cables				

1105AC-CE

Note:
 Make a copy of this page or visit the Skyjack web site:
www.skyjack.com for a printable copy.

Table 4.9 EC Declaration of Conformity

EC Declaration of Conformity

We, SKYJACK INC., declare under our sole responsibility that the product **Mobile Elevating Work Platform**

Model number: [*]

Serial number: [*]

to which this declaration relates is in conformity with the following directives:

Machinery Directive 2006/42/EC
 With guidance from Harmonized European Standard EN280:2013.
 Notified body: [*]

EC Type Examination Certificate No: [*]

Directive 2000/14/EC: [*]

Directive 2004/108/EC
 With guidance from Harmonized European Standard EN13309:2000.
 Testing laboratory: [*]

The person authorized to compile the Technical Construction File:
 [*]

Place of issue:
 [*]

Note: In case of unauthorized modification, this Declaration becomes invalid.

Test and Validation:

Quality:

[*] For information refer to the English Declaration of Conformity provided with your MEWP.

Label Legend

The diagram illustrates five safety label types, each with a colored header and a text box. The labels are:

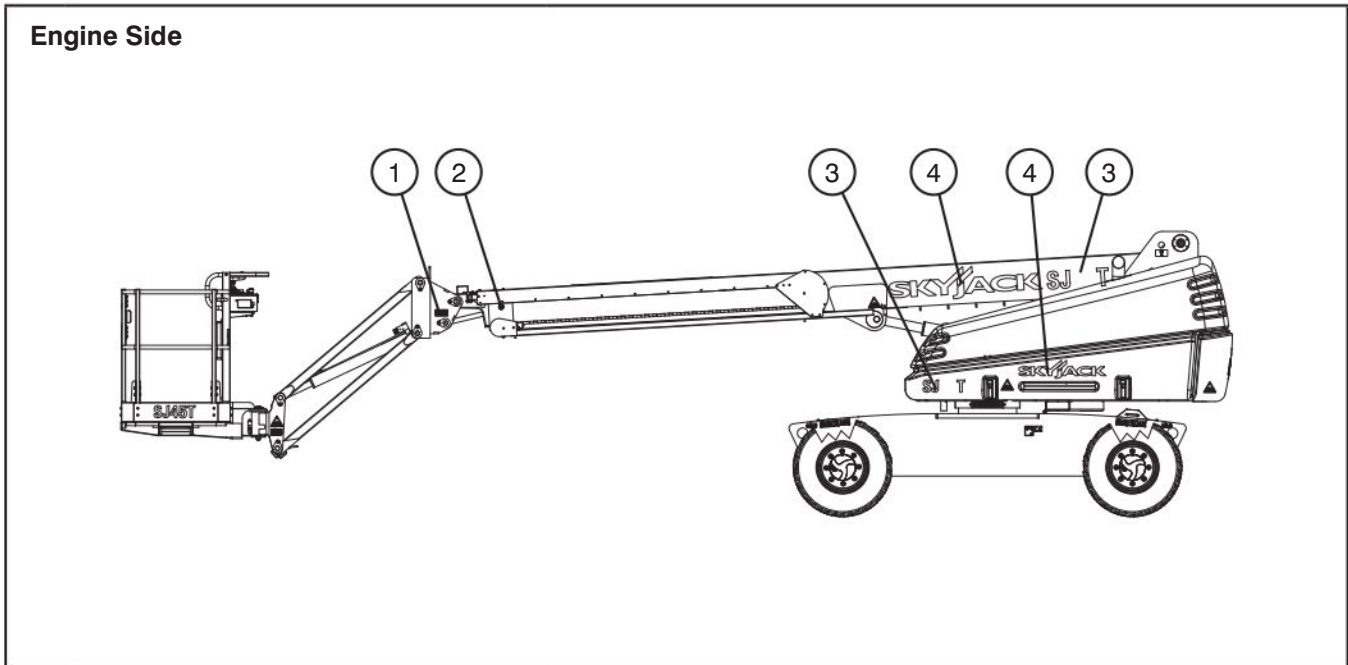

- Safety Red:** Header contains a warning triangle and a book icon. Text: "Safety Red indicates DANGER."
- Safety Orange:** Header contains a warning triangle and a book icon. Text: "Safety Orange indicates WARNING."
- Safety Yellow:** Header contains a warning triangle and a book icon. Text: "Safety Yellow indicates CAUTION."
- Safety Green:** Header contains a book icon. Text: "Safety Green indicates emergency lowering."
- Safety Blue:** Header contains a book icon. Text: "Safety Blue indicates safety information."





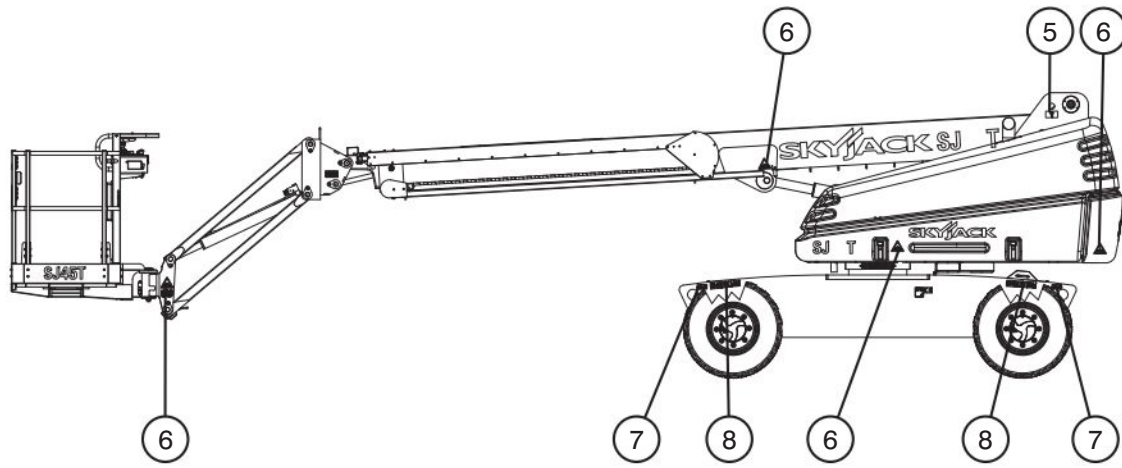

No.	Label Pictorial	Description
1		<p>Crushing Hazard Danger - Crushing hazard</p>
2		<p>Warning - Do Not Alter Do not alter or disable limit switches or other safety devices.</p>
3		<p>Model Number* Product Identifier *Model number will vary, may not be as shown.</p>
4		<p>Skyjack Logo Skyjack</p>

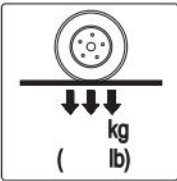
Engine Side (Continued)

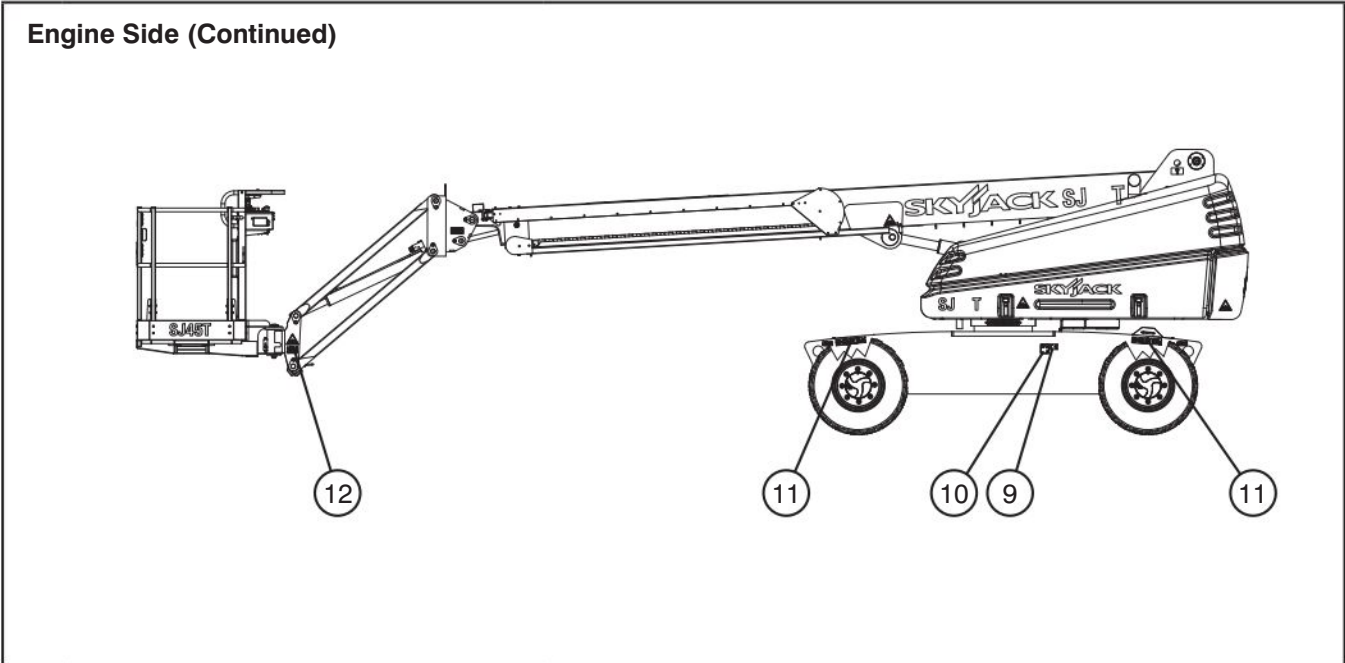

No.	Label Pictorial	Description
5		<p>Lift Points</p> <p>Only use these points for lifting.</p>
6		<p>Body Crushing Hazard</p> <p>Danger - Body crushing hazard</p>
7		<p>Lift and Tie Down Points</p> <p>Only use these points for lifting or tying down.</p>
8		<p>Wheel Load*</p> <p>Indicates rated wheel load. *Wheel load will vary over different MEWPs.</p>

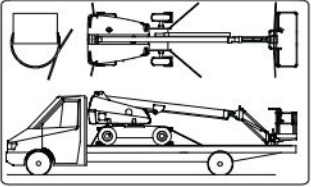

No.	Label Pictorial	Description
9		<p>“CE” CE rating mark</p>
10		<p>Sound Power Level Guaranteed maximum sound power level</p>
11		<p>Wheel Specifications Refer to manual for wheel type, offset, pressure and torque.</p>
12		<p>Tie Down Points Only use these points for tying down.</p>

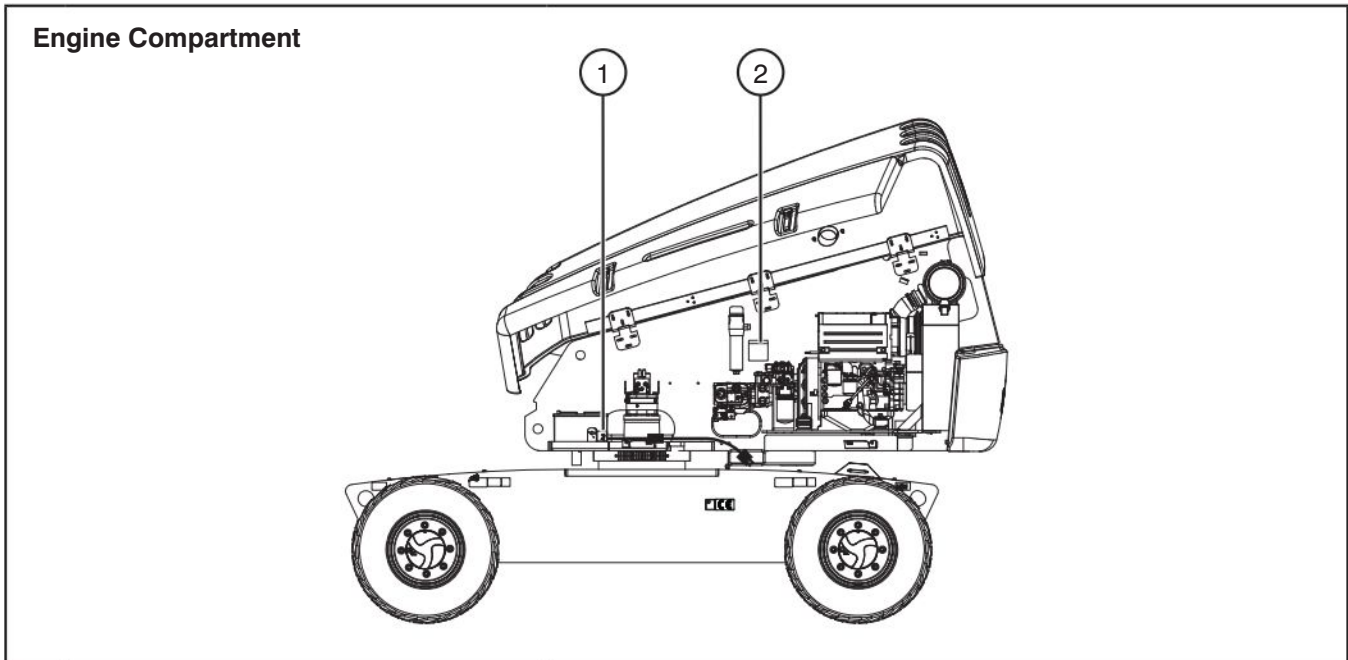

No.	Label Pictorial	Description
1	<p>The pictorial label is enclosed in a rounded rectangle. It contains several symbols: a padlock at the top left, a small circle at the top right, a battery symbol with a plus sign on the right and a minus sign on the left at the bottom left, and a central illustration of the main power disconnect lever with a dashed line indicating its movement.</p>	<p>Main Power Disconnect</p> <p>Main power disconnect lever</p>

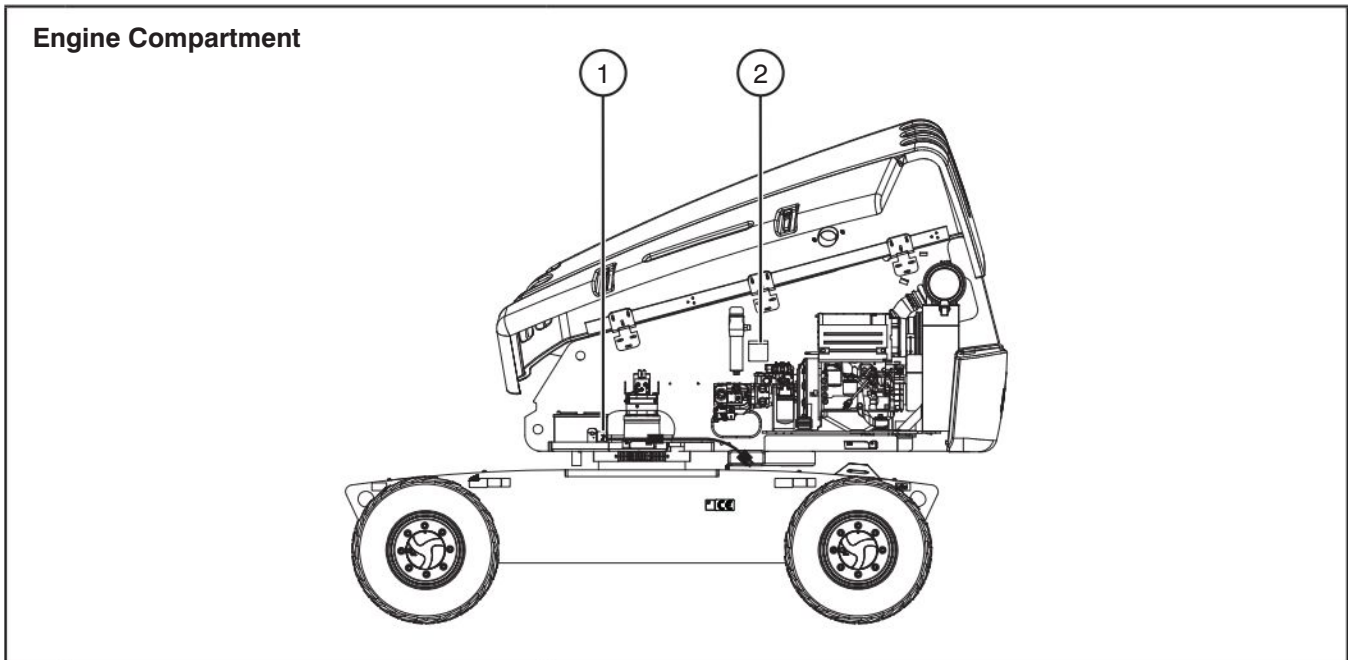



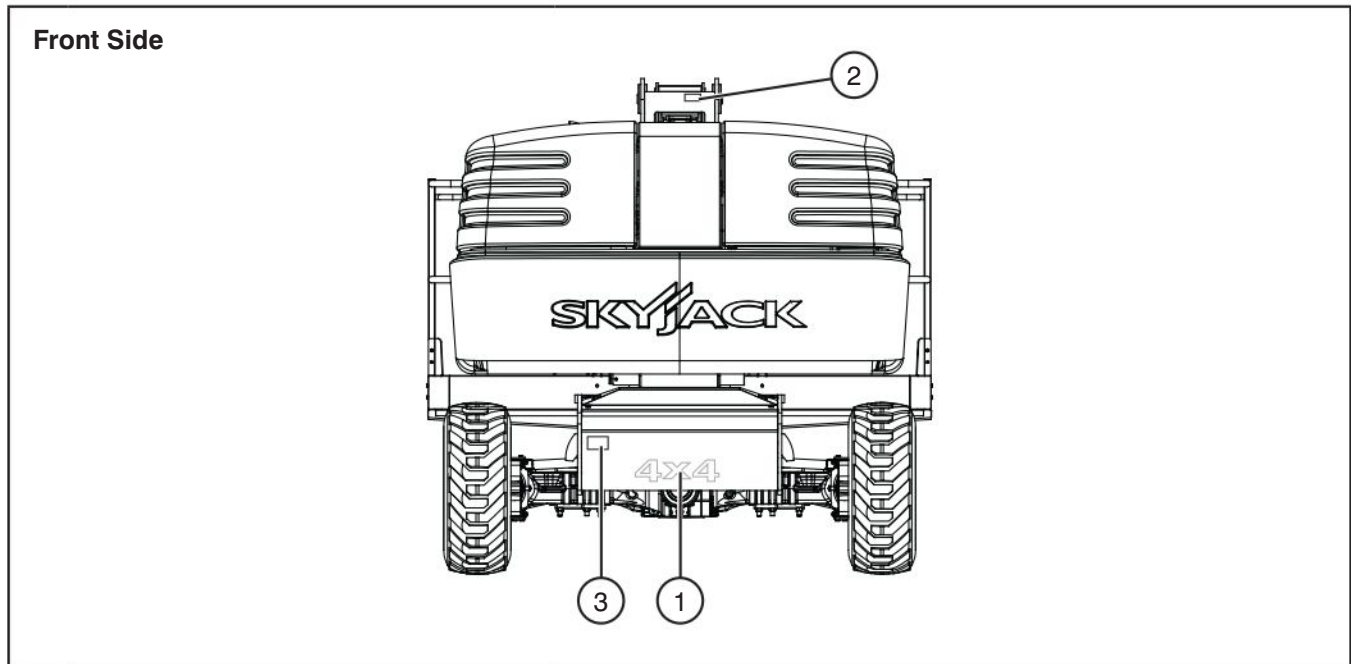

No.	Label Pictorial	Description
2		<p>Winching/Towing/Pushing Procedure Refer to Operating manual.</p> <ol style="list-style-type: none"> 1. Block or chock wheels to prevent MEWP from rolling. 2. Turn main power disconnect switch to off position. At engine side: 3. Locate bypass valve (marked with yellow colour) on inboard side of drive pump. 4. Rotate bypass valve flat using pliers or 1/4" (7mm) wrench by 90 degrees (clockwise). At hydraulic tank side: 5. Locate brake valve and pump. 6. Push in black knob. 7. Pump by pushing red knob in and out until firm resistance is felt or until 300 psi/21 bar shows on the gauge (if equipped). Brake is now released. 8. A) Remove blocks from wheels. B) Push/tow/winch to desired location. 9. Block or chock wheels to prevent MEWP from rolling. At hydraulic tank side: 10. Reset brake by pulling out black knob. At engine side: 11. Close bypass valve by rotating 90 degrees (counterclockwise) to normal condition (flat is parallel to shaft axis). <p style="text-align: center;">NOTE</p> <p style="text-align: center;">Before operation, ensure all blocks are removed from wheels.</p>

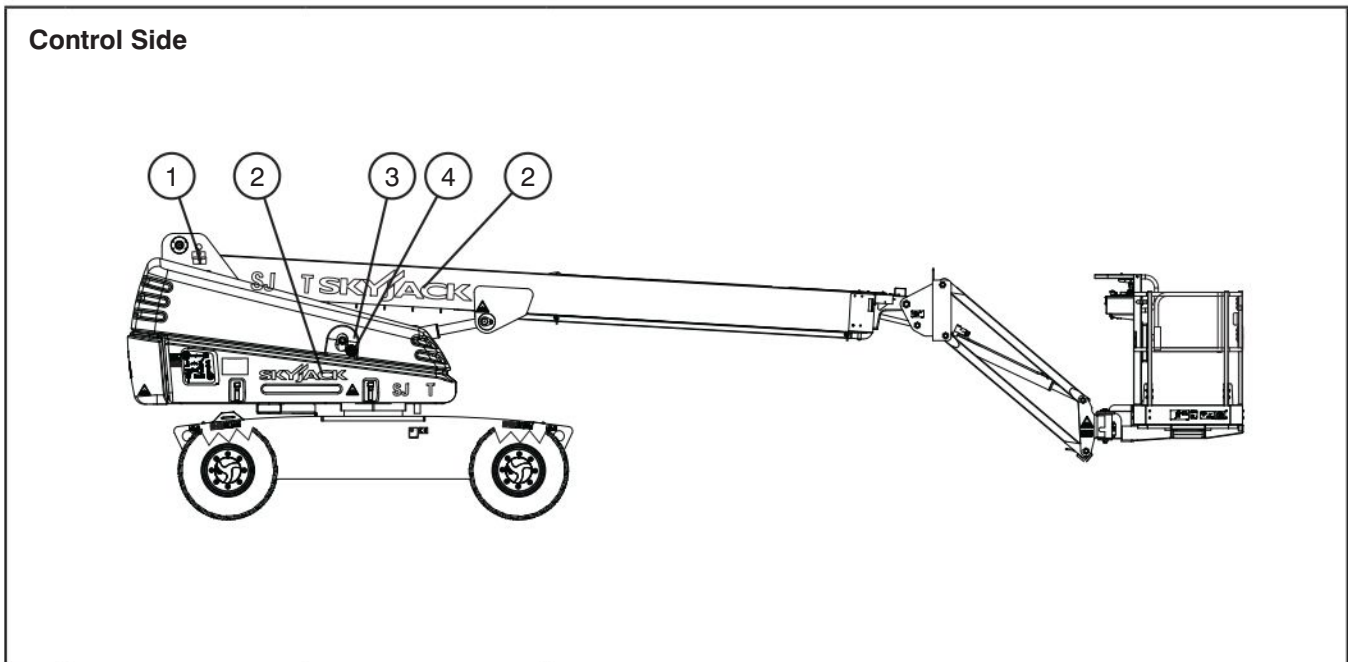





No.	Label Pictorial	Description
1		<p>4x4 (If Equipped)</p> <p>Product identifier - 4 wheel drive</p>
2		<p>Warning - Do Not Alter</p> <p>Do not alter or disable limit switches or other safety devices.</p>
3		<p>Serial Plate*</p> <p>Product identification and specifications *Serial plate will vary, may not be as shown.</p>

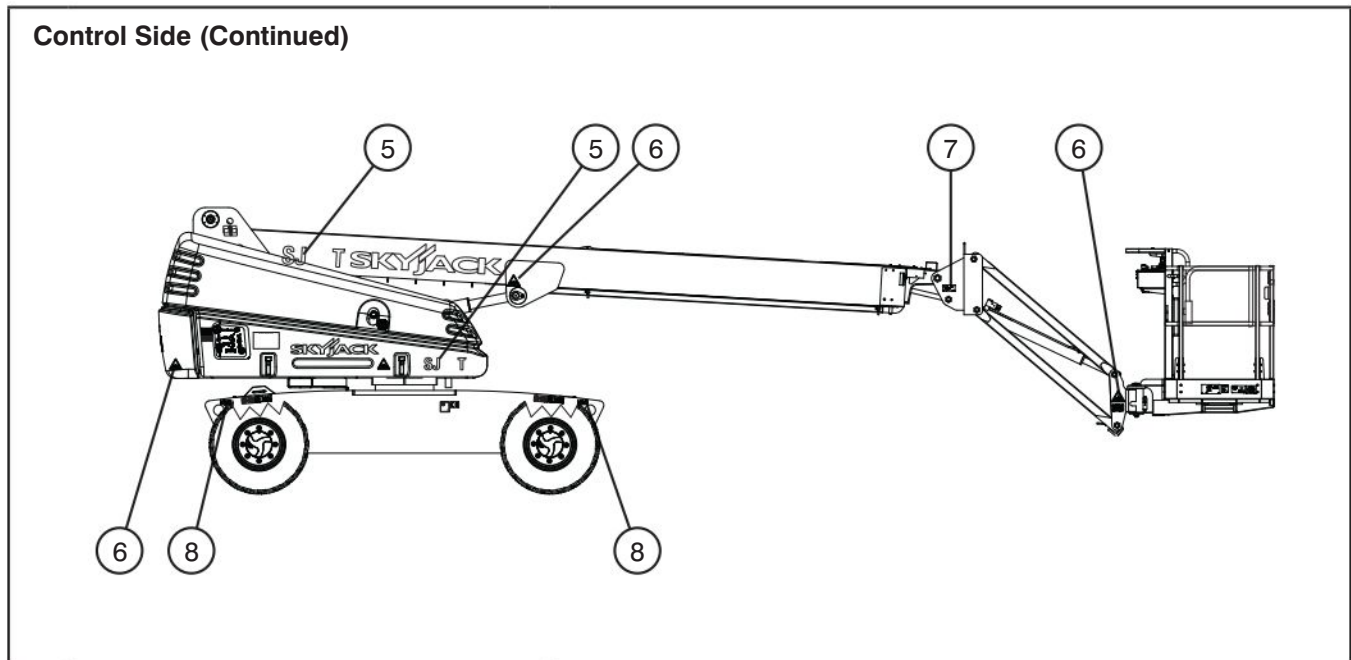



No.	Label Pictorial	Description
1		<p>Lift Points Only use these points for lifting.</p>
2		<p>Skyjack Logo Skyjack</p>
3		<p>Diesel Ultra Low Sulfur Only Diesel Ultra Low Sulfur Only</p> <p>Diesel Use diesel fuel only.</p>
4		<p>No Smoking Do not smoke near this location.</p>

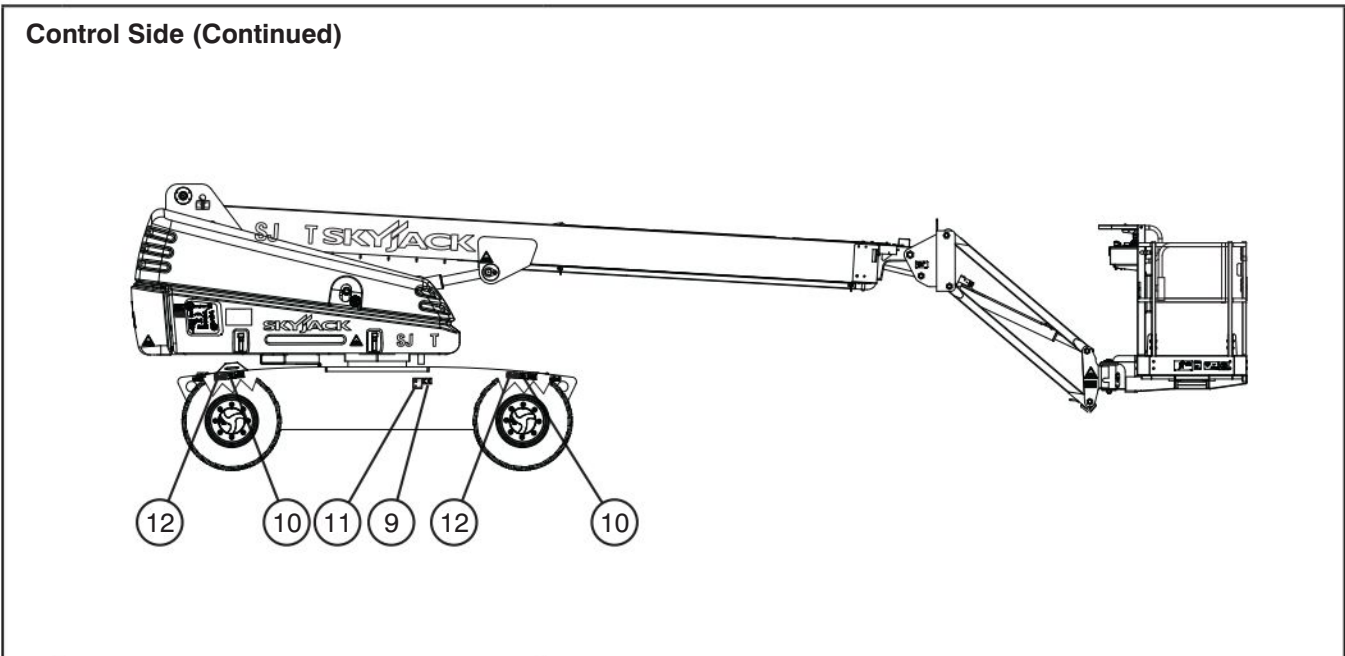

No.	Label Pictorial	Description
5		<p>Model Number*</p> <p>Product Identifier *Model number will vary, may not be as shown.</p>
6		<p>Body Crushing Hazard</p> <p>Danger - Body crushing hazard</p>
7		<p>Crushing Hazard</p> <p>Danger - Crushing hazard</p>
8		<p>Lift and Tie Down Points</p> <p>Only use these points for lifting or tying down.</p>

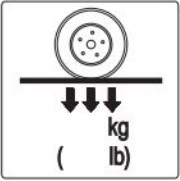

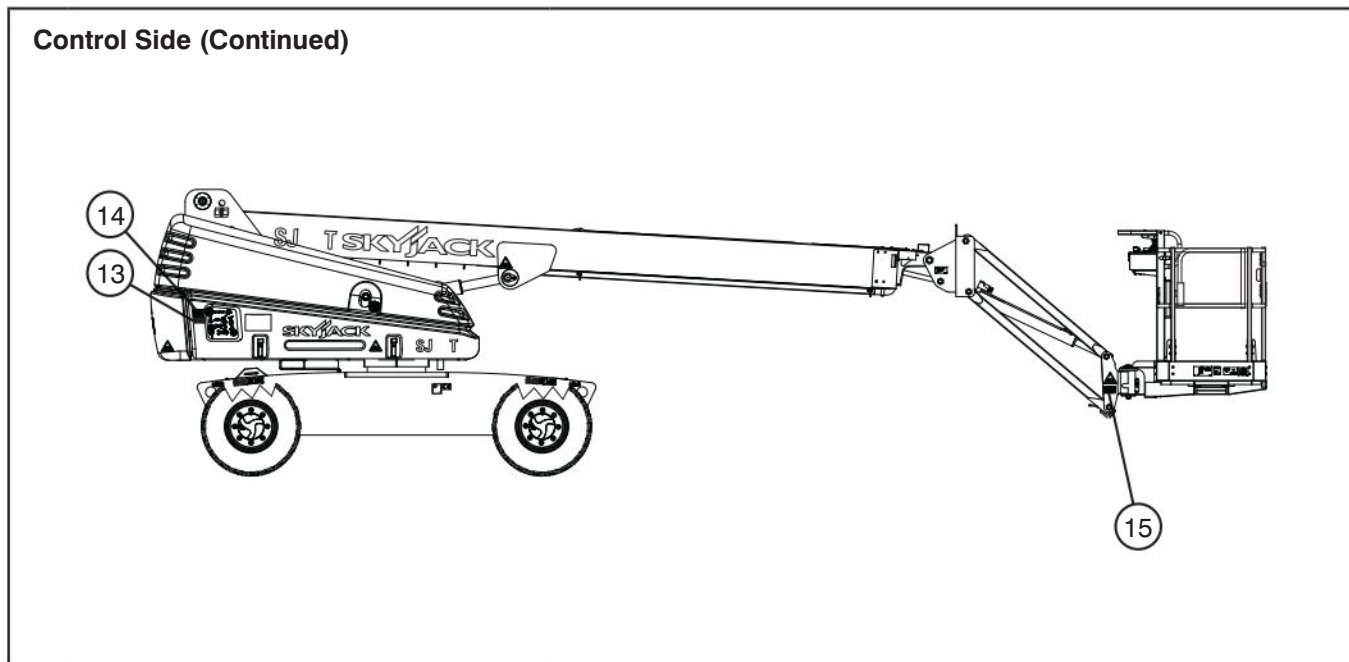

No.	Label Pictorial	Description
9		<p>“CE” CE rating mark</p>
10		<p>Wheel Load* Indicates rated wheel load. *Wheel load will vary over different MEWPs.</p>
11		<p>Sound Power Level Guaranteed maximum sound power level</p>
12		<p>Wheel Specifications Refer to manual for wheel type, offset, pressure and torque.</p>

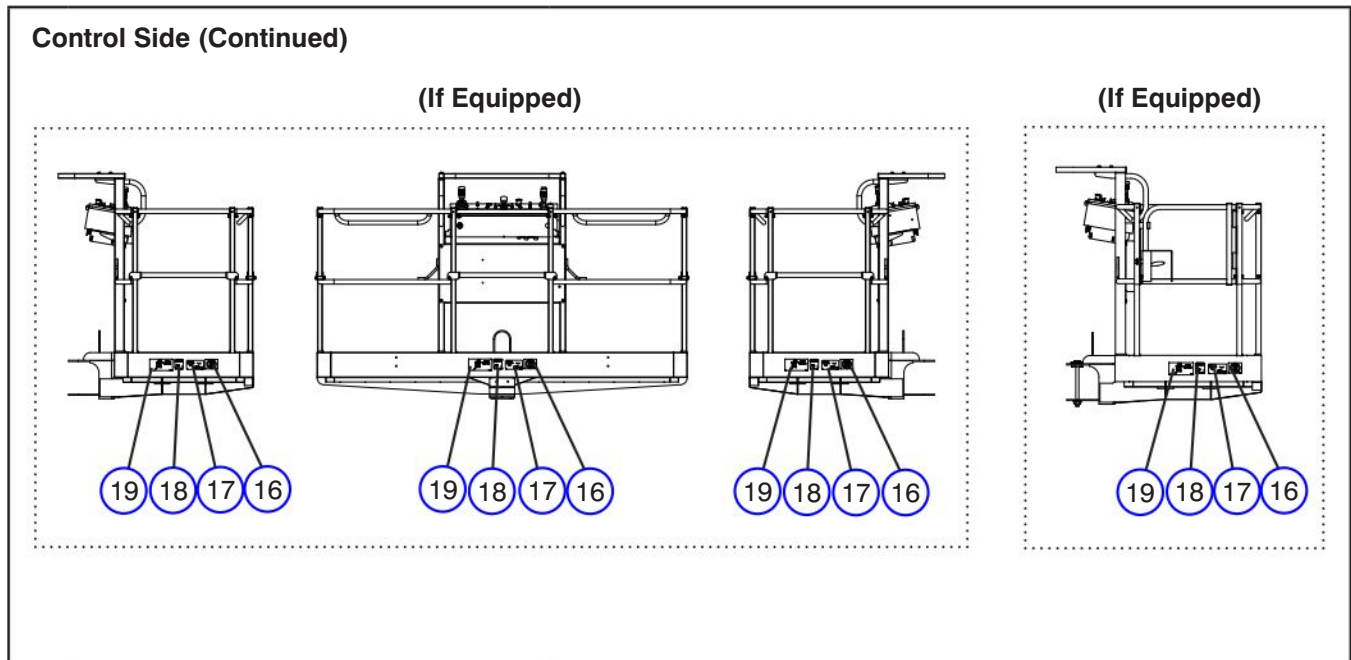

No.	Label Pictorial	Description
13		<p>Annual Inspection</p> <p>Ensure that work platform has received annual inspection prior to operation.</p>
14		<p>Emergency Lowering Procedure</p> <p>In case of emergency, follow procedure outlined in label to lower the platform.</p>
15		<p>Tie Down Points</p> <p>Only use these points for tying down.</p>

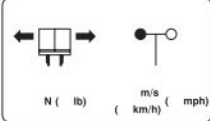

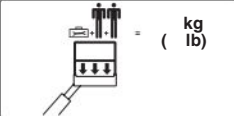

No.	Label Pictorial	Description
16		<p>No Jewelry</p> <p>Caution - Do not wear jewelry.</p>
17		<p>Horizontal Load Rating</p> <p>Apply no more than the indicated side load. Operate below indicated wind speed only.</p>
18		<p>Operator's Daily Inspection</p> <p>Refer to the Operating manual. Perform visual inspection and function tests at the beginning of each shift. Refer to Table 4.7 Maintenance and Inspection Schedule.</p>
19		<p>Platform Capacity*</p> <p>Rated work load in each configuration. Rated work load includes the weight of both personnel and material, and maximum number of people in each configuration. Do not exceed total weight or maximum number of people. Load platform uniformly.</p> <p>*Platform capacity will vary over different MEWPs.</p>

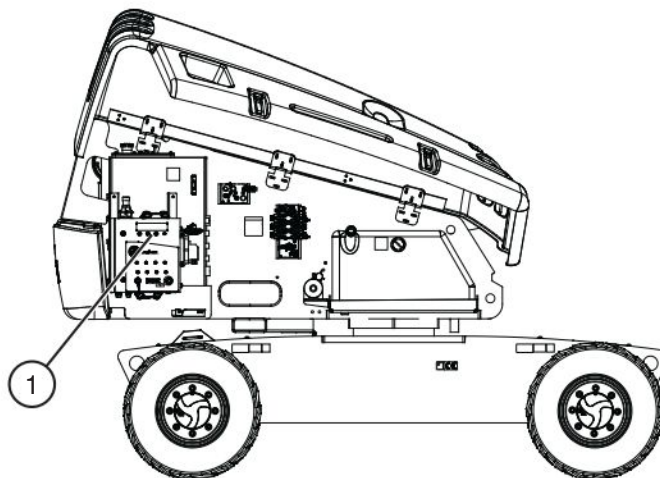
Control Compartment

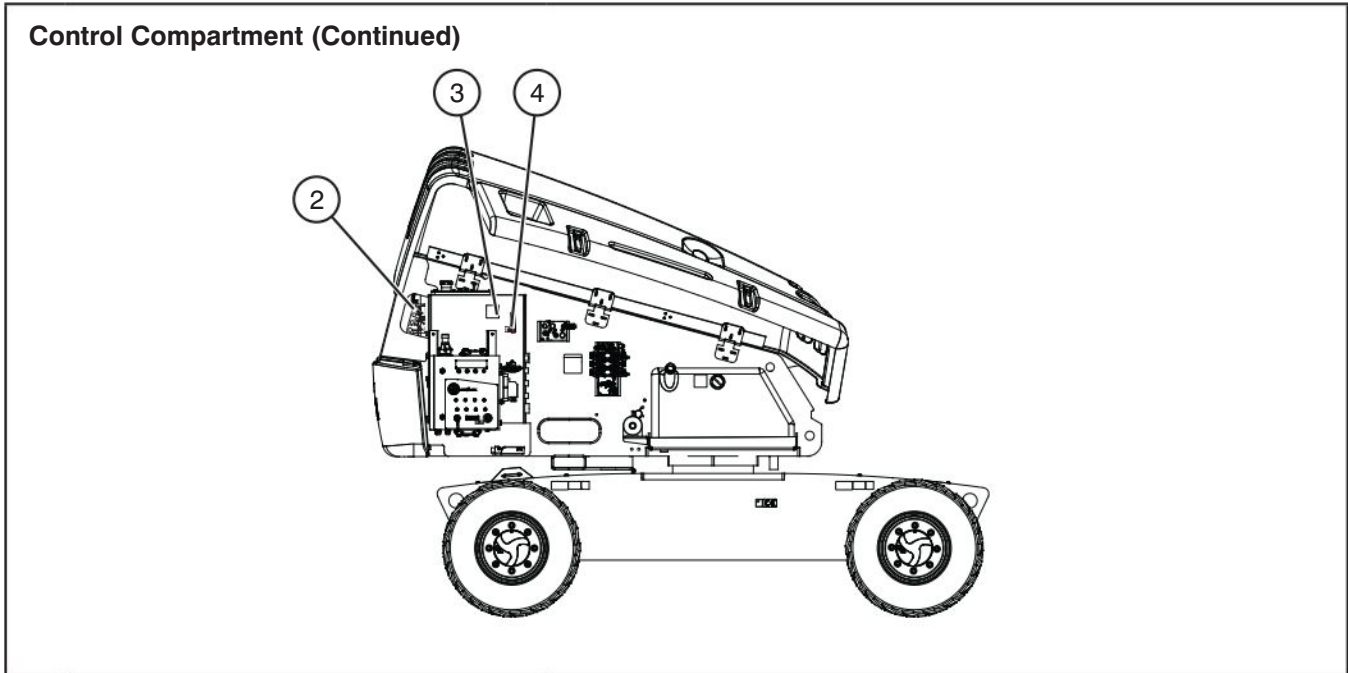

No.	Label Pictorial	Description
1		<p>Base Control Console</p> <p>Push “” breaker back in to reset. Select and hold “” to enable error blink code for engine control unit (ECU).</p> <p>Read “” operating manual.</p> <p>Push and hold “” to start engine.</p> <p>With engine off, push and hold “” to enable the emergency power unit for “” emergency descent.</p> <p>Do not operate emergency power unit if platform capacity is exceeded “”.</p> <p>Push and hold “” to enable base control functions.</p> <p>Select “” to rotate platform to the left or “” to rotate to the right.</p> <p>Select “” to tilt platform up or “” to tilt platform down.</p> <p>Select “” to move jib up or “” to move jib down.</p> <p>Select “” to rotate turret to the left or “” to rotate to the right.</p> <p>Select “” to raise main boom or “” to lower main boom.</p> <p>Select “” to extend fly boom or “” to retract fly boom.</p> <p>Select “” to turn engine off, “” to enable base control console or “” to enable platform control console.</p> <p>Push “” emergency stop to stop engine and disable controls.</p>



No.	Label Pictorial	Description
2		<p>Grease Points Maintenance</p> <p>Refer to service and maintenance manual “” for lubricating MEWP.</p>
3		<p>Hydraulic Oil</p> <p>Replace hydraulic fluid with Shell Tellus T46 or approved alternate (see Table 4.2b). (Note: Cold weather starting temperatures can be improved with Skyjack options. Please consult your nearest Skyjack service center.)</p>
4		<p>Hydraulic Oil Level</p> <p>Indicates minimum/maximum oil level.</p>

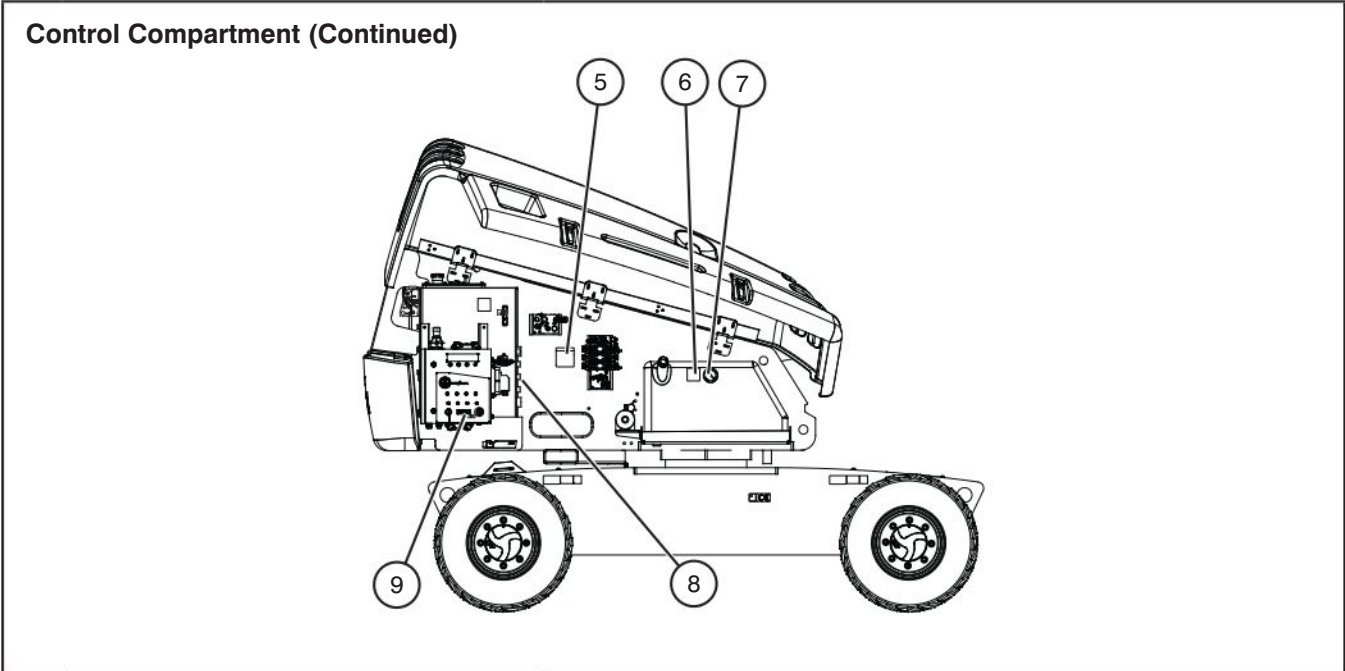

No.	Label Pictorial	Description
5		<p>Winching/Towing/Pushing Procedure Refer to Operating manual.</p> <ol style="list-style-type: none"> 1. Block or chock wheels to prevent MEWP from rolling. 2. Turn main power disconnect switch to off position. At engine side: 3. Locate bypass valve (marked with yellow colour) on inboard side of drive pump. 4. Rotate bypass valve flat using pliers or 1/4" (7mm) wrench by 90 degrees (clockwise). At hydraulic tank side: 5. Locate brake valve and pump. 6. Push in black knob. 7. Pump by pushing red knob in and out until firm resistance is felt or until 300 psi/21 bar shows on the gauge (if equipped). Brake is now released. 8. A) Remove blocks from wheels. B) Push/tow/winch to desired location. 9. Block or chock wheels to prevent MEWP from rolling. At hydraulic tank side: 10. Reset brake by pulling out black knob. At engine side: 11. Close bypass valve by rotating 90 degrees (counterclockwise) to normal condition (flat is parallel to shaft axis). <p style="text-align: center;">NOTE</p> <p style="text-align: center;">Before operation, ensure all blocks are removed from wheels.</p>

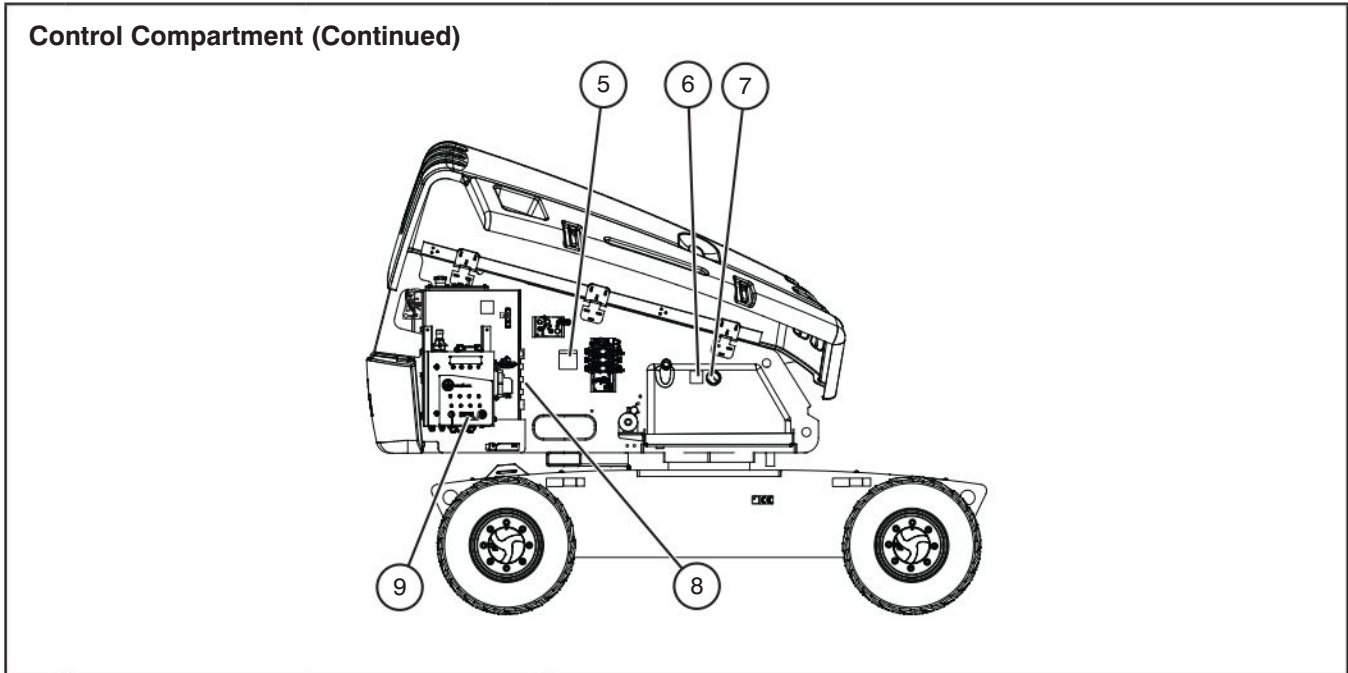

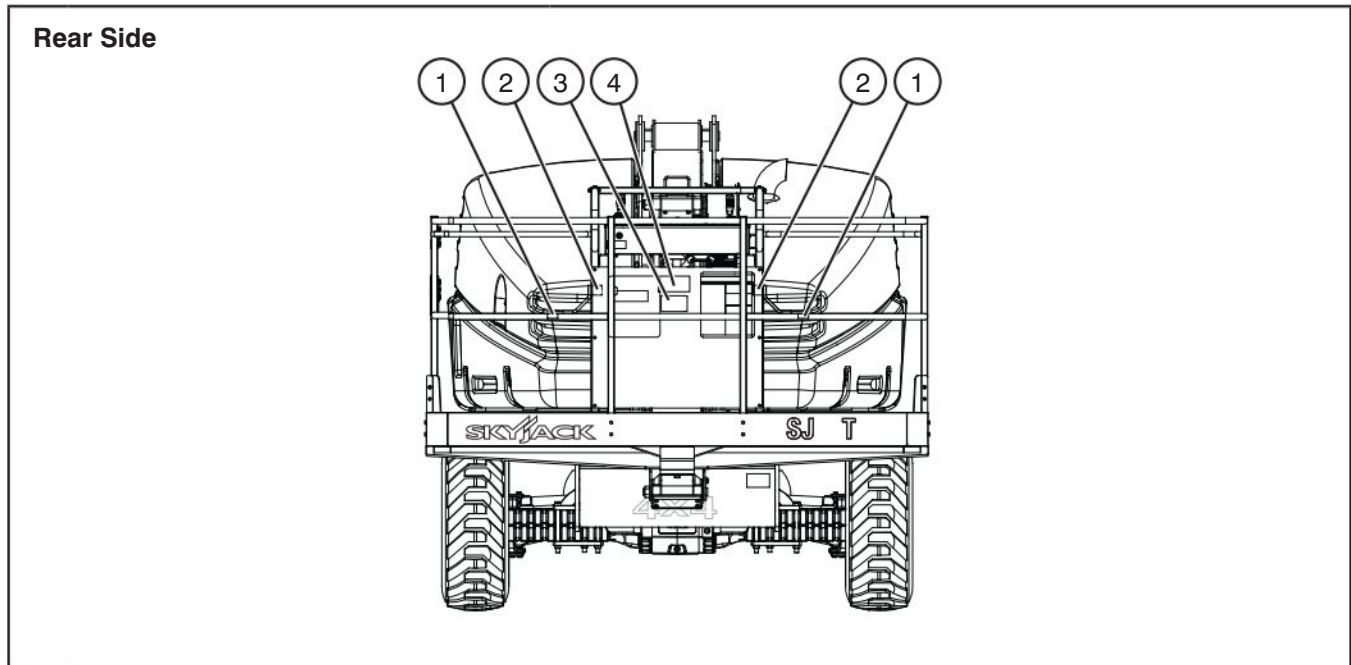

No.	Label Pictorial	Description
6		<p>Diesel Ultra Low Sulfur Only Diesel Ultra Low Sulfur Only</p> <p>Diesel Use diesel fuel only.</p>
7		<p>No Smoking Do not smoke near this location.</p>
8		<p>Connect AC Supply Connect AC supply here.</p>
9		<p>Glow Plug Procedure</p> <p>When “” glow plug (diesel) light is on, “” wait and do not “” start engine.</p>



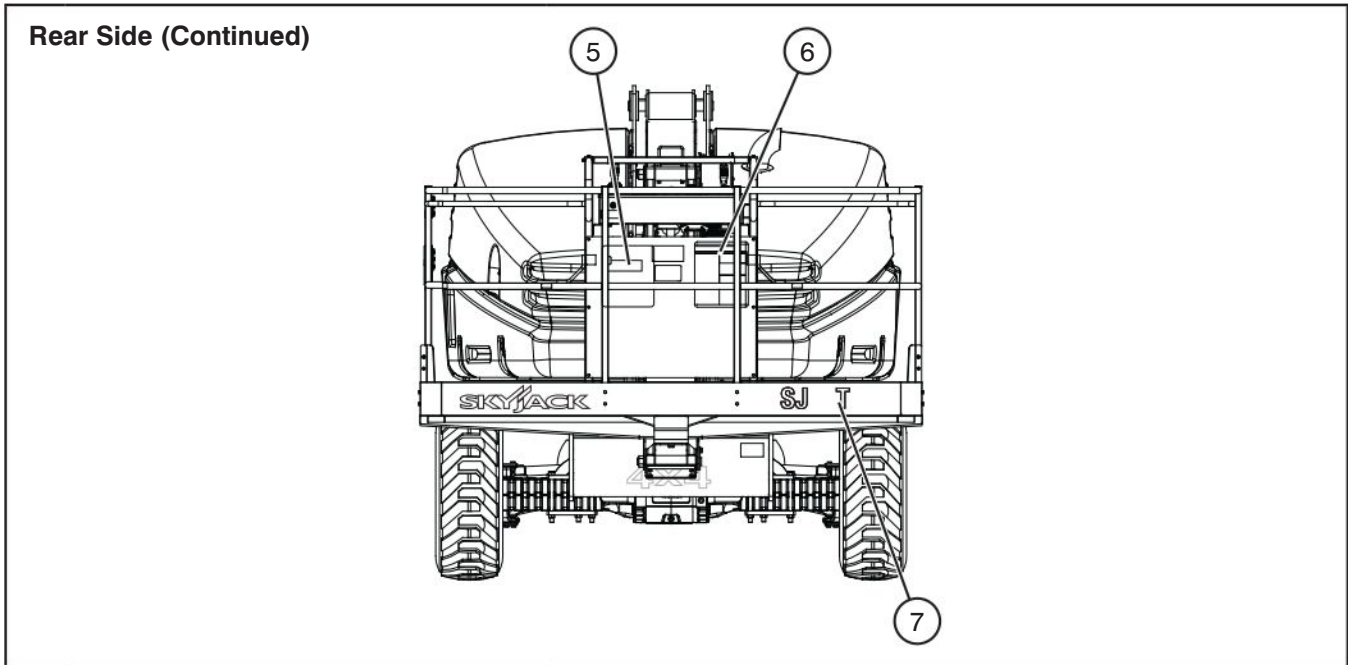

No.	Label Pictorial	Description
1		<p>Warning - No Step</p> <p>No step warning</p>
2		<p>Harness Anchorage</p> <p>Anchor safety belt/harness tethers here.</p>
3		<p>Horizontal Load Rating</p> <p>Apply no more than indicated side load. Operate below indicated wind speed only.</p>
4		<p>Platform Capacity*</p> <p>Rated work load in each configuration. Rated work load includes the weight of both personnel and material, and maximum number of people in each configuration. Do not exceed total weight or maximum number of people. Load platform uniformly.</p> <p>*Platform capacity will vary over different MEWPs.</p>



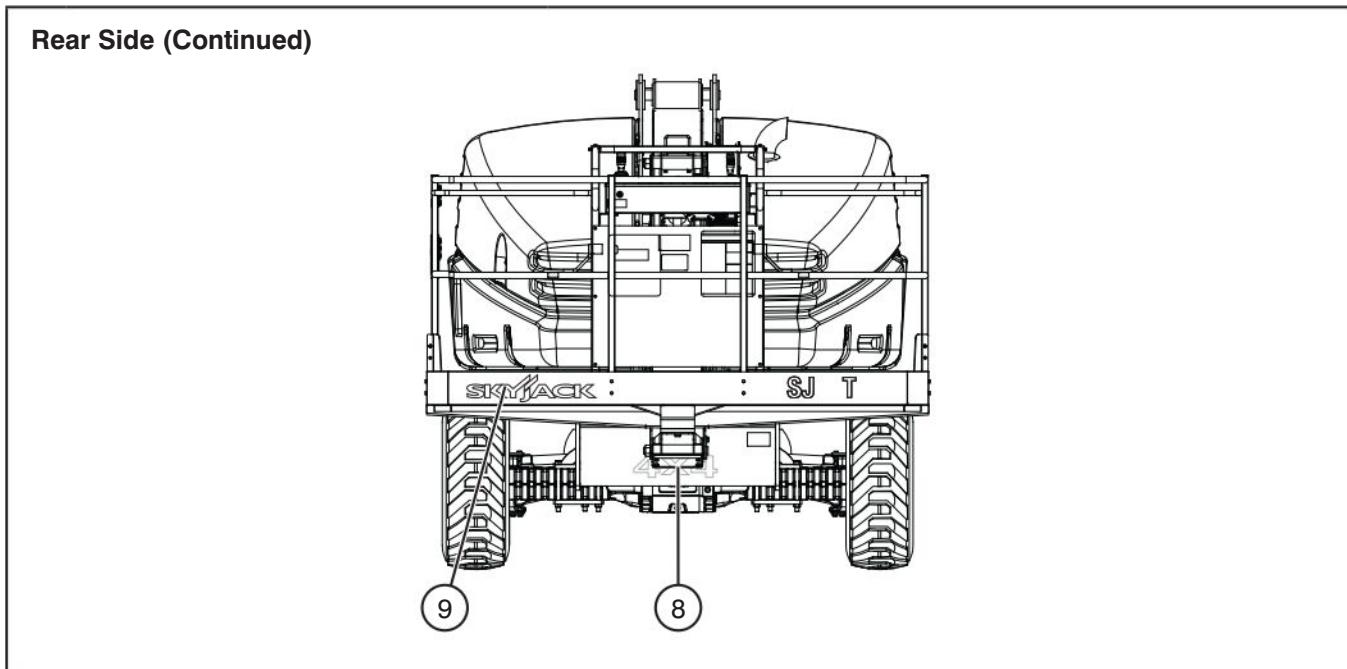





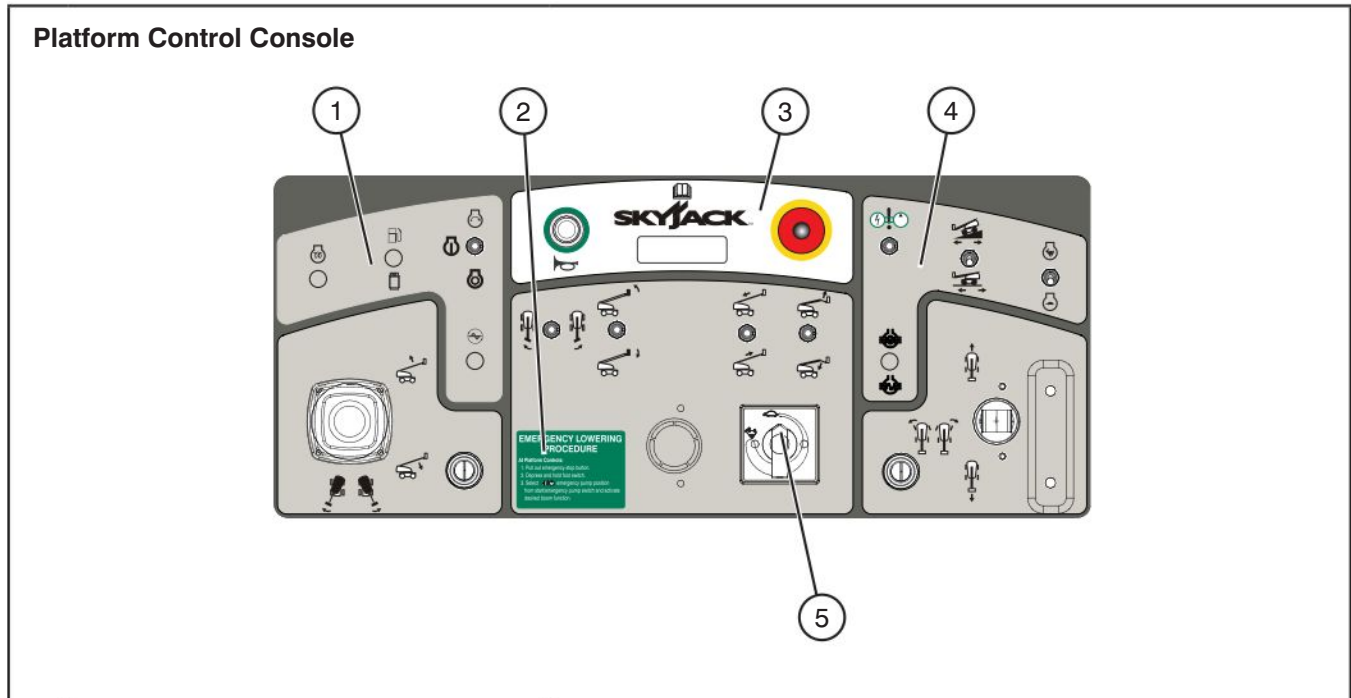

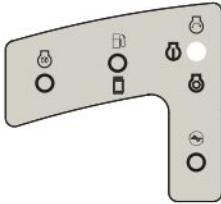









No.	Label Pictorial	Description
5		<p>Manual Box</p> <p>Indicates location of operating manual.</p>
6		<p>Hazard Identification</p> <p>Refer to Section 1: Safety Rules. Read and understand outlined risks associated with this work platform prior to operation.</p>
7		<p>Model Number*</p> <p>Product Identifier *Model number will vary, may not be as shown.</p>

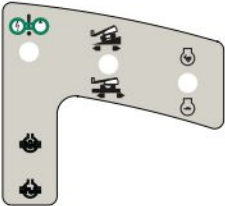

No.	Label Pictorial	Description
8		<p>4x4 (If Equipped)</p> <p>Product identifier - 4 wheel drive</p>
9		<p>Skyjack Logo</p> <p>Skyjack</p>





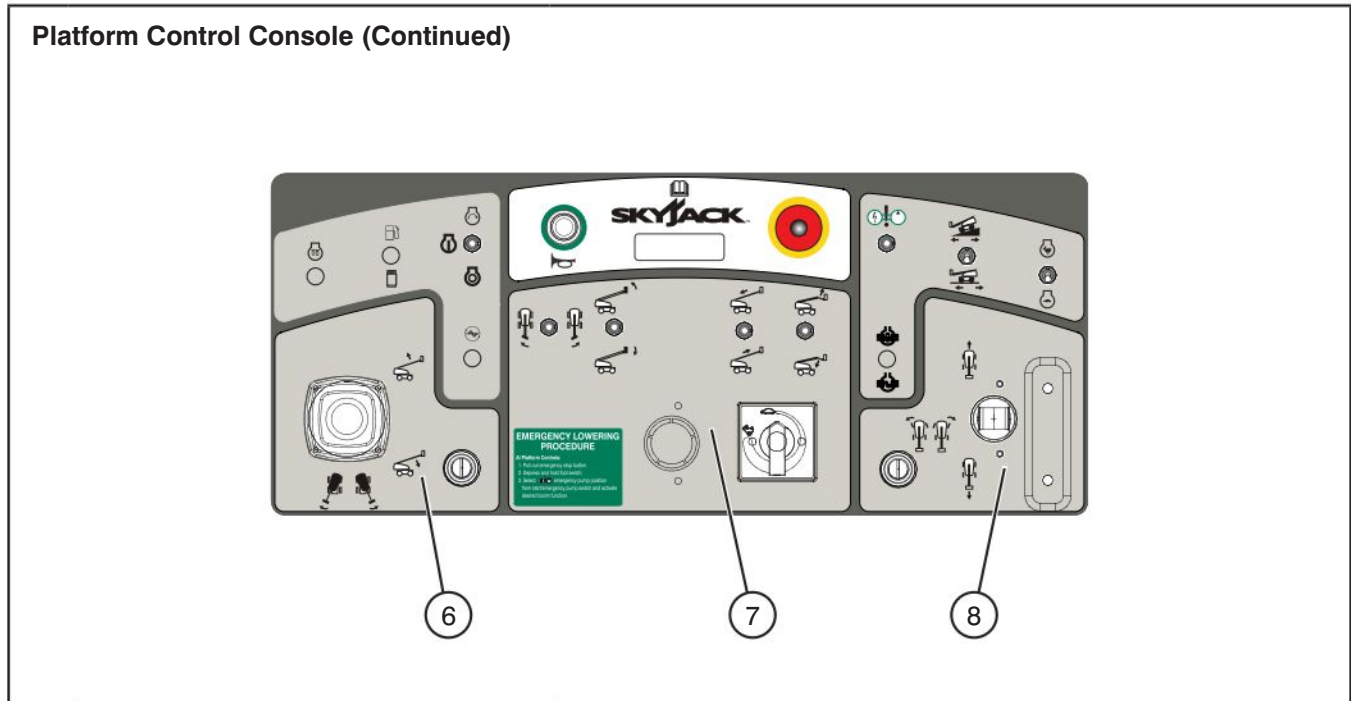

No.	Label Pictorial	Description
1		<p>Glow Plugs/Start Engine</p> <p>Select “” to energize glow plugs.</p> <p>Push and hold “” to start engine and then return to “” on position or select “” to turn engine off.</p> <p>Select “” to turn hydraulic generator on or “” to turn it off.</p>
2		<p>Emergency Lowering Procedure</p> <p>Follow procedure outlined in label to lower the platform.</p>
3		<p>E-Stop/Horn</p> <p>Select “” to sound horn.</p> <p>Read operating manual “”.</p> <p>Push “” emergency stop to stop engine and disable controls.</p>
4		<p>Engine Controls/Emergency Power Unit</p> <p>Select “” to enable emergency power unit.</p> <p>Select “” low torque when driving on level ground or “” high torque when driving on a slope.</p> <p>Select either “” high or “” low engine throttle speed.</p>
5		<p>Boom Speed Adjuster Dial</p> <p>Adjust dial to vary speed of fly boom extension/retraction, jib raising/lowering and platform rotation movements.</p>

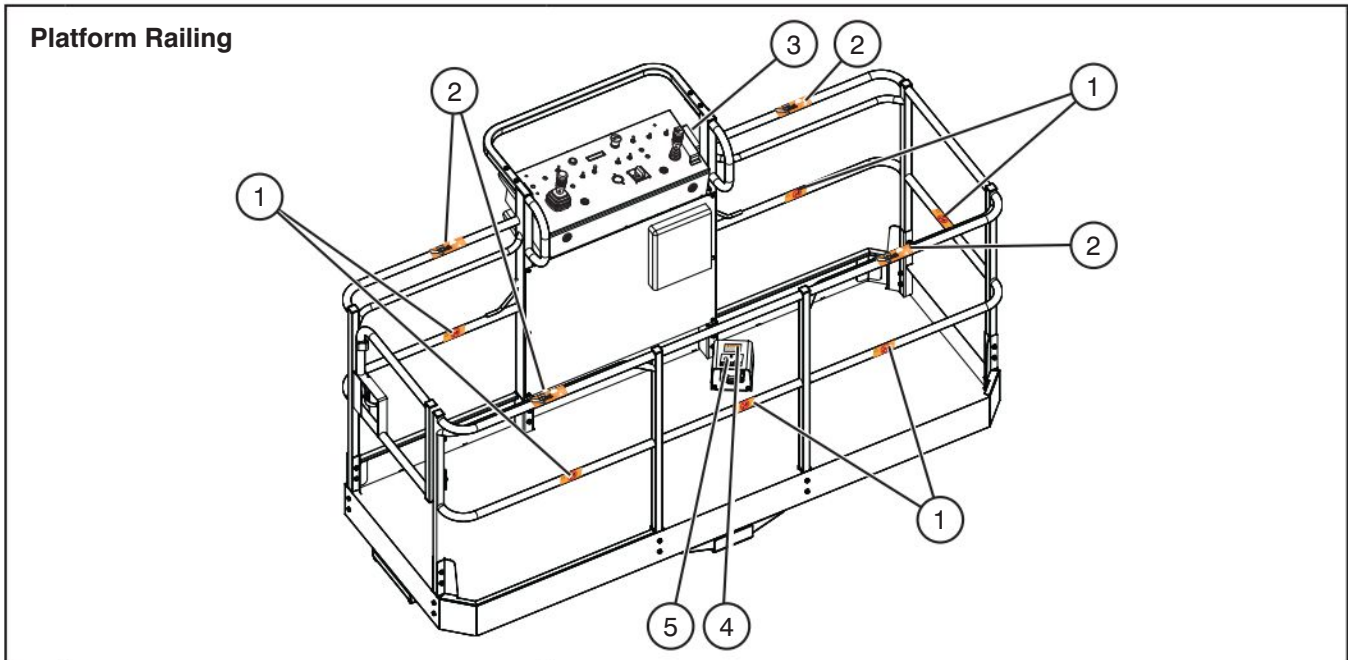

No.	Label Pictorial	Description
6		<p>Boom/Turret Controller</p> <p>Push and hold controller in this direction “” to rotate turret to the left or “” to rotate turret to the right.</p> <p>Push and hold the controller in this direction “” to raise main boom or “” to lower main boom.</p>
7		<p>Boom/Jib/Platform Controls</p> <p>Select “” to rotate platform to the left or “” to the right.</p> <p>Select “” to tilt platform up or “” to tilt platform down.</p> <p>Select “” to extend fly boom or “” to retract fly boom.</p> <p>Select “” to move jib up or “” to move jib down.</p>
8		<p>Drive/Steer Controller</p> <p>Push and hold controller in this direction “” to drive forward or “” to drive backward.</p> <p>Push and hold controller in this direction “” to steer left or “” to steer right.</p>

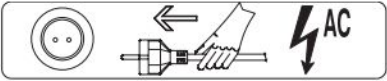

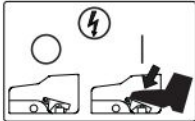
No.	Label Pictorial	Description
1		<p>Warning - No Step No step warning</p>
2		<p>Crushing Hazard Danger - Crushing hazard</p>
3		<p>Connect AC Supply Connect AC supply here.</p>
4		<p>Warning - Do Not Alter Do not alter or disable limit switches or other safety devices.</p>
5		<p>Footswitch Enable (On/Off) Depress and hold footswitch to enable platform function.</p>

Optional Equipment/Attachments

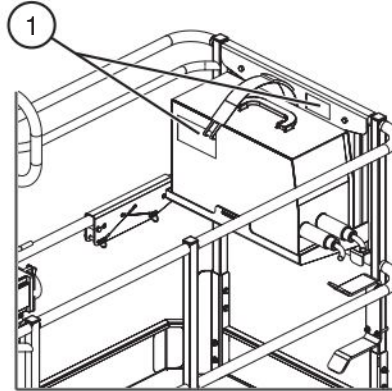

No.	Label Pictorial	Description
1		<p>Welder Weight</p> <p>Indicates rated weight of welder.</p>

SKYJACK[™]

www.skyjack.com